

SUPER AE

Low Voltage Switchgears

User's Manual

AE1000 – 6300-SS

AE4000-SSA/SSC

AE1000 – 3200-SH

About this Manual

The texts, illustrations, diagrams and examples in this manual are only intended as help for the installation, handling and operation of the low voltage air circuit breakers of the SUPER AE series.

If you have any questions regarding the installation and operation of the equipment described in this manual, please do not hesitate to contact your sales office or one of your Mitsubishi distribution partners (see cover page).

You can also obtain information updates and answers to frequently asked questions from our Internet website:

<http://www.mitsubishi-automation.com>

No part of this manual may be reproduced, copied, stored in any kind of information retrieval system or distributed without the prior express written consent of MITSUBISHI ELECTRIC EUROPE B.V.

MITSUBISHI ELECTRIC EUROPE B.V. reserves the right to change the specifications of its products and/or the contents of this manual at any time and without prior notice.

© 12/2002

**Low Voltage Air Circuit Breaker
SUPER AE
Instruction Manual
Article No.: 69647-C**

| Version | Changes / Additions / Corrections |
|------------------|--|
| A 08/1999 pdp | — |
| B 06/2002 pdp-sk | Added breaker type SUPER AE4000-SSA |
| C 12/2002 pdp-sk | Added B type relay data, description and characteristics New characteristics for S type relay New circuit diagram for S type relay Added setting example for S type relay |
| | |

Safety Information

For use by trained personnel only

This manual is only intended to be used by trained and fully-qualified electrical personnel who are familiar with the safety standards required for circuit breakers and distribution systems. Project planning, installation, commissioning, maintenance and testing of the equipment may only be performed by trained and fully-qualified electrical staff who are familiar with the safety standards required for circuit breakers and distribution systems.

Proper use of the equipment

The products of the SUPER AE series are only intended for the uses specified in this manual. Strict observance of all the instructions and specifications provided in this manual is essential for the proper operation of this equipment. Only accessories and peripherals explicitly approved by Mitsubishi Electric may be used with these air circuit breakers.

Any use of the equipment not conforming to this definition shall be deemed to be improper use.

Relevant safety regulations

All the relevant safety and accident prevention regulations must be observed in all stages of project planning, installation, commissioning, maintenance and testing of this equipment.

Observance of the following regulations is particularly important (this list does not necessarily contain all regulations relevant for you):

- VDE regulation
 - VDE 0100
Regulations for the installation of high-power electrical systems with rated voltages up to 1,000V
 - VDE 0105
Operation of power systems
 - VDE 0113
Safety of machines; electrical equipment of machines
 - VDE 0160
Electronic equipment for high-power electrical systems
 - Fire prevention regulations
 - Accident prevention regulations
 - VBG No. 4: Electrical systems and equipment
-

Danger symbols

In this manual, warnings of hazards and potential problems are identified with the following two symbols:



DANGER:

This symbol indicates that failure to observe the safety procedures described can result in severe electrical shock hazards that can cause serious injury to the operating staff. In some case, such a hazard can also be lethal.



CAUTION:

Failure to observe the procedures identified by this symbol can result in incorrect settings or damage to the equipment or other property.

General safety information and safety procedures

The following safety recommendations provide general guidelines for using circuit breakers together with other equipment. All these instructions must be observed strictly in all stages of project planning, installation, commissioning, maintenance and testing of the electrical systems.



DANGER:

- *Observe all safety and accident prevention regulations relevant to your specific application. Always disconnect the power supply before installing, connecting, opening or performing any other work on the breakers, components and devices.*
- *Do not touch the terminals when the breaker is under power. There is a risk of electric shock.*
- *All breakers, components and units must be installed in a suitable housing equipped with proper shock hazard protection and fitted with an approved cover and protective device.*
- *Check all cables connected to the equipment regularly for breaks or faulty insulation. If defects are found in the cables, immediately disconnect the power supply to the cables and the equipment and replace the defective cables.*
- *Always make sure that the power supply voltage matches the rated voltage range of the equipment before connection.*
- *Do not over rate this device, otherwise ground fault or short-circuit fault may occur due to dielectric breakdown. In worst case explosion may occur due to a short-circuit protection failure.*
- *Adequate safety measures must be implemented to ensure that cable- or wirebreak on the signal side cannot result in undefined operating conditions.*



CAUTION:

- *All the specified physical and electrical parameters must be observed strictly when using these air circuit breakers.*
 - *Do not install in areas subject to high temperatures, high humidity, dust, corrosive gas, vibrations, shocks etc. To do so may result in malfunction or fire.*
 - *Be shure to tighten the terminal screws to the torque specified in this instruction manual. The tightening of the terminal screws should checked periodically. Failure to do so may result in fire.*
 - *Should the circuit breaker trip automatically, always clear the source of the malfunction before closing the breaker again. Failure to do so may result in fire.*
-

Contents

1 Introduction

| | | |
|-------|---------------------------------|-----|
| 1.1 | External View | 1-1 |
| 1.1.1 | AE1000–AE3200-SS – Fixed Type | 1-1 |
| 1.1.2 | AE1000–AE3200-SS – Drawout type | 1-2 |
| 1.1.3 | AE1000–AE3200-SH – Drawout type | 1-3 |
| 1.1.4 | AE4000–AE6300-SS – Drawout type | 1-4 |
| 1.2 | Internal construction | 1-5 |

2 Set-up

| | | |
|--------|-------------------------------------|------|
| 2.1 | Unpacking | 2-1 |
| 2.2 | Handling | 2-2 |
| 2.3 | Dimensions | 2-4 |
| 2.3.1 | Fixed types AE1000–AE3200-SS/SH | 2-4 |
| 2.3.2 | Drawout types AE1000–AE3200-SS | 2-5 |
| 2.3.3 | Drawout types AE1000–AE3200-SH | 2-6 |
| 2.3.4 | Fixed types AE4000–SSA | 2-7 |
| 2.3.5 | Drawout types AE4000–SSA | 2-8 |
| 2.3.6 | Fixed types AE4000–SSC | 2-9 |
| 2.3.7 | Drawout types AE4000–SSC | 2-9 |
| 2.3.8 | Drawout types AE4000–AE6000-SS | 2-10 |
| 2.4 | Weight | 2-11 |
| 2.4.1 | Standard series | 2-11 |
| 2.4.2 | High-performance series | 2-11 |
| 2.5 | Storage | 2-12 |
| 2.6 | Installation | 2-13 |
| 2.6.1 | Fixed types | 2-13 |
| 2.6.2 | Drawout type | 2-14 |
| 2.7 | Connections | 2-18 |
| 2.7.1 | Main connectors | 2-18 |
| 2.7.2 | Electromagnetic force | 2-20 |
| 2.8 | Wiring diagram | 2-21 |
| 2.8.1 | Diagram due to terminal designation | 2-21 |
| 2.8.2 | Diagram according to EN50005 | 2-23 |
| 2.9 | Charging operation | 2-25 |
| 2.9.1 | Manual charging | 2-25 |
| 2.9.2 | Motor charging | 2-25 |
| 2.10 | Opening / closing operation | 2-27 |
| 2.10.1 | Manual operation | 2-27 |
| 2.10.2 | Electrical operation | 2-28 |

| | | |
|--------|---|------|
| 2.11 | Operation of the drawout mechanism. | 2-29 |
| 2.11.1 | Drawout operation. | 2-29 |
| 2.11.2 | Insert operation | 2-30 |

3 Operation

| | | |
|-------|--|------|
| 3.1 | Setting the operating characteristics. | 3-1 |
| 3.1.1 | Setting procedure | 3-1 |
| 3.1.2 | Sealing | 3-3 |
| 3.1.3 | Resetting the indicator. | 3-3 |
| 3.1.4 | Characteristics setting for the S type. | 3-4 |
| 3.1.5 | Characteristics setting for the M type | 3-6 |
| 3.1.6 | Characteristics setting for the B type. | 3-8 |
| 3.1.7 | Setting example for S Type – General use | 3-10 |
| 3.1.8 | Operating system of each device | 3-12 |
| 3.2 | Checking the tripping characteristics | 3-14 |
| 3.2.1 | Checking with a field tester (Y-160 and Y-2000). | 3-14 |
| 3.2.2 | Checking with the Y-160 | 3-15 |
| 3.2.3 | Checking with the Y-2000 | 3-18 |

4 Accessories

| | | |
|-------|--|------|
| 4.1 | Preparing the breaker | 4-1 |
| 4.1.1 | Overview. | 4-2 |
| 4.2 | Auxiliary switch (AX). | 4-3 |
| 4.2.1 | Removal | 4-3 |
| 4.2.2 | Installation. | 4-4 |
| 4.3 | Shunt trip device (SHT) | 4-5 |
| 4.3.1 | Removal | 4-5 |
| 4.3.2 | Installation. | 4-5 |
| 4.4 | Closing coil (CC). | 4-6 |
| 4.4.1 | Removal | 4-6 |
| 4.4.2 | Installation. | 4-6 |
| 4.5 | Undervoltage trip device (UVT) | 4-7 |
| 4.5.1 | Removal of the coil | 4-7 |
| 4.5.2 | Installation of the coil. | 4-7 |
| 4.5.3 | Removal of the controller | 4-8 |
| 4.5.4 | Installation of the controller | 4-8 |
| 4.6 | Motor charging device (MD) | 4-10 |
| 4.6.1 | Removal | 4-10 |
| 4.6.2 | Installation. | 4-11 |
| 4.7 | Cell switch (CL). | 4-13 |
| 4.7.1 | Removal | 4-13 |
| 4.7.2 | Installation. | 4-13 |
| 4.7.3 | Mounting of the CL adaptor. | 4-14 |

| | | |
|--------|---|------|
| 4.8 | Cylinder lock (CYL)..... | 4-15 |
| 4.8.1 | Removal | 4-15 |
| 4.8.2 | Installation..... | 4-15 |
| 4.9 | Castell lock (CAL)..... | 4-16 |
| 4.9.1 | Removal | 4-16 |
| 4.9.2 | Installation..... | 4-16 |
| 4.10 | Counter (CNT) | 4-17 |
| 4.11 | Safety shutter (SST)..... | 4-18 |
| 4.11.1 | Operation and handling..... | 4-18 |
| 4.11.2 | Installation | 4-21 |
| 4.12 | Shorting b-contact (SBC) | 4-23 |
| 4.12.1 | Removal | 4-23 |
| 4.12.2 | Installation..... | 4-25 |
| 4.13 | Mis-insertion preventor (MIP) | 4-26 |
| 4.13.1 | Preparation | 4-26 |
| 4.13.2 | Installing points | 4-27 |
| 4.14 | Mechanical interlock (MI) | 4-28 |
| 4.14.1 | Preparation | 4-29 |
| 4.14.2 | MI unit mounting on the breaker | 4-30 |
| 4.14.3 | Adjustment | 4-31 |
| 4.14.4 | Operation check between 2 breakers | 4-32 |
| 4.14.5 | Maintenance | 4-32 |
| 4.15 | Door interlock (DI)..... | 4-33 |
| 4.15.1 | DI unit mounting (installation of DI unit) | 4-33 |
| 4.15.2 | Door lock unit mounting..... | 4-35 |
| 4.15.3 | Releasing the door interlock | 4-37 |
| 4.15.4 | Adjustment | 4-38 |
| 4.15.5 | Operation check | 4-39 |
| 4.16 | Test jumper (TJ) | 4-40 |
| 4.16.1 | Inserting and removing the test jumper on the breaker..... | 4-40 |
| 4.16.2 | Inserting and removing the test jumper on the cradle..... | 4-42 |
| 4.17 | External ZCT for load circuits | 4-43 |
| 4.17.1 | Precautions when installing the external ZCT for load circuits | 4-43 |
| 4.17.2 | Precautions when installing the external ZCT on the transformer ground wire | 4-44 |
| 4.17.3 | Examples of connections | 4-45 |
| 4.18 | Push-button cover..... | 4-47 |
| 4.18.1 | Installation..... | 4-47 |
| 4.19 | Terminal adapter..... | 4-48 |
| 4.19.1 | Installation of front terminal adapter (FTA) | 4-48 |
| 4.19.2 | Installation of vertical terminal adapter (VTA) | 4-49 |

5 Maintenance and Inspection

| | | |
|-------|--|------|
| 5.1 | Preparation | 5-1 |
| 5.2 | Troubleshooting | 5-4 |
| 5.3 | Guidelines for inspections and replacement. | 5-5 |
| 5.3.1 | Introduction | 5-5 |
| 5.3.2 | Inspections and renewals according to period and environment of usage. | 5-5 |
| 5.3.3 | Inspections and replacement according to number of operation cycles | 5-6 |
| 5.4 | Concerning the inspections | 5-7 |
| 5.4.1 | Initial inspection. | 5-7 |
| 5.4.2 | Periodic Inspections | 5-9 |
| 5.4.3 | Inspections after the breaking operation | 5-12 |
| 5.5 | Troubleshooting | 5-13 |
| 5.5.1 | The breaker cannot close | 5-13 |
| 5.5.2 | Switching off is disabled | 5-14 |
| 5.5.3 | Charging is not possible | 5-15 |
| 5.5.4 | Unusual temperature rise | 5-15 |
| 5.5.5 | Abnormality of the electronic trip device | 5-16 |
| 5.5.6 | Drawout/insertion operation is not possible. | 5-17 |
| 5.5.7 | Malfunction of peripheral devices | 5-18 |

A Appendix

| | | |
|-------|--|-----|
| A.1 | Specifications | A-1 |
| A.1.1 | Technical notes. | A-1 |
| A.2 | Operating conditions | A-2 |
| A.2.1 | Normal operating conditions | A-2 |
| A.2.2 | Special operating conditions. | A-2 |
| A.2.3 | Internal resistance, reactance and power consumption | A-3 |
| A.2.4 | Deratings by ambient temperature | A-4 |
| A.3 | Index. | A-7 |

1 Introduction

1.1 External View

1.1.1 AE1000–AE3200-SS – Fixed Type

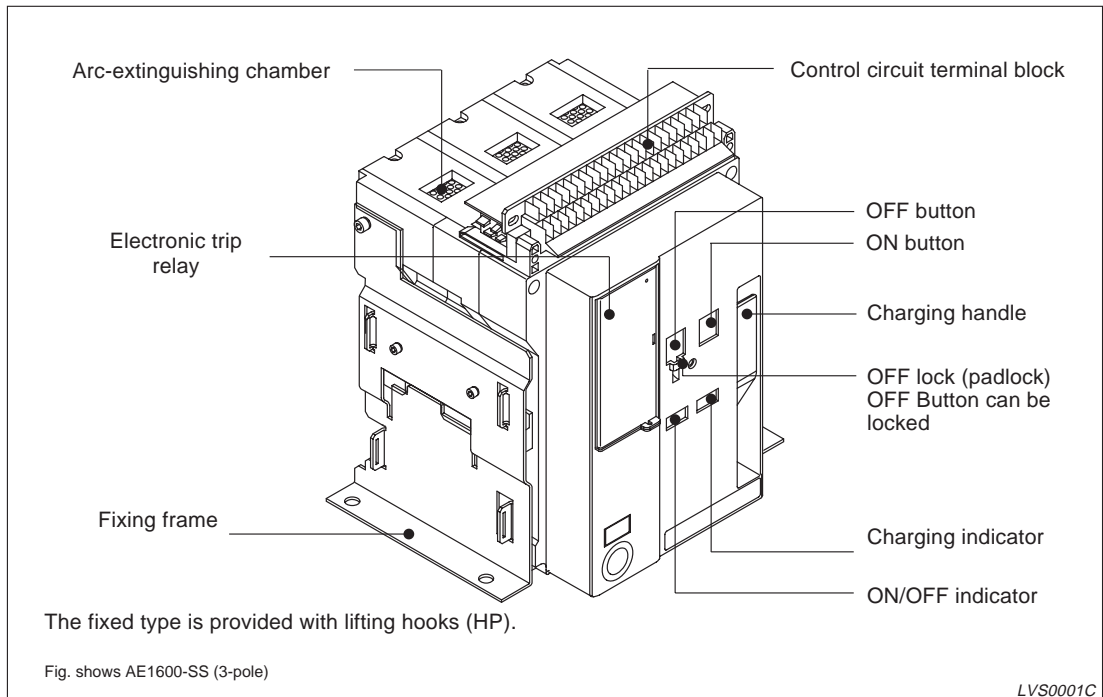

Fig. 1-1: Front view of the AE-SS

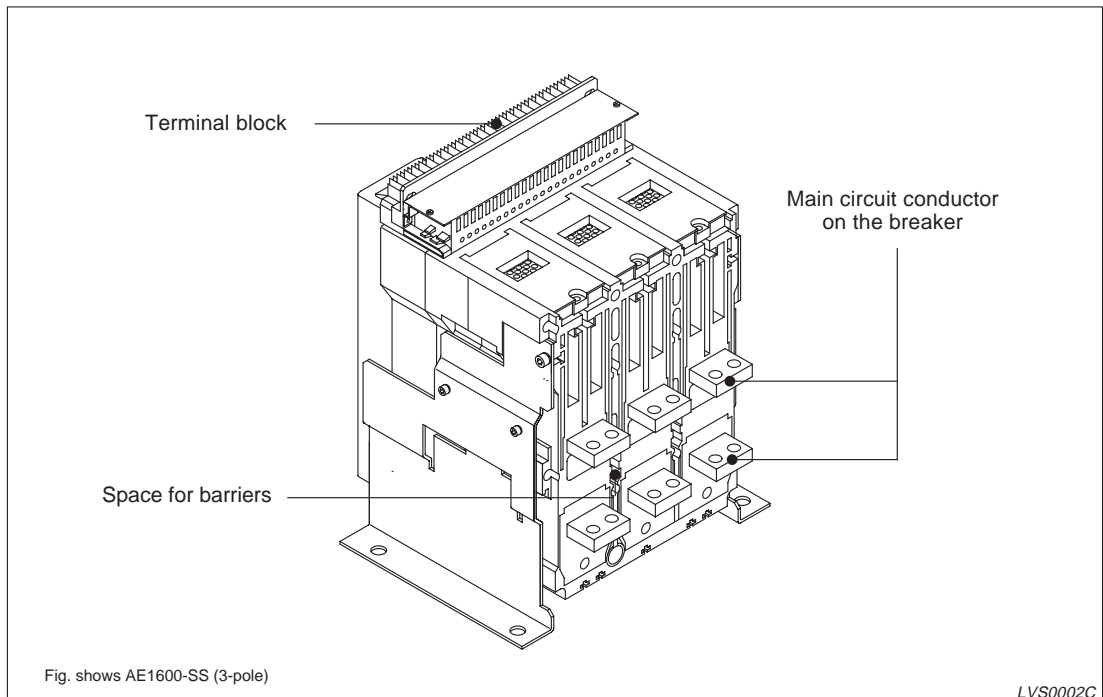

Fig. 1-2: Rear view of the AE-SS

1.1.2 AE1000–AE3200-SS – Drawout type

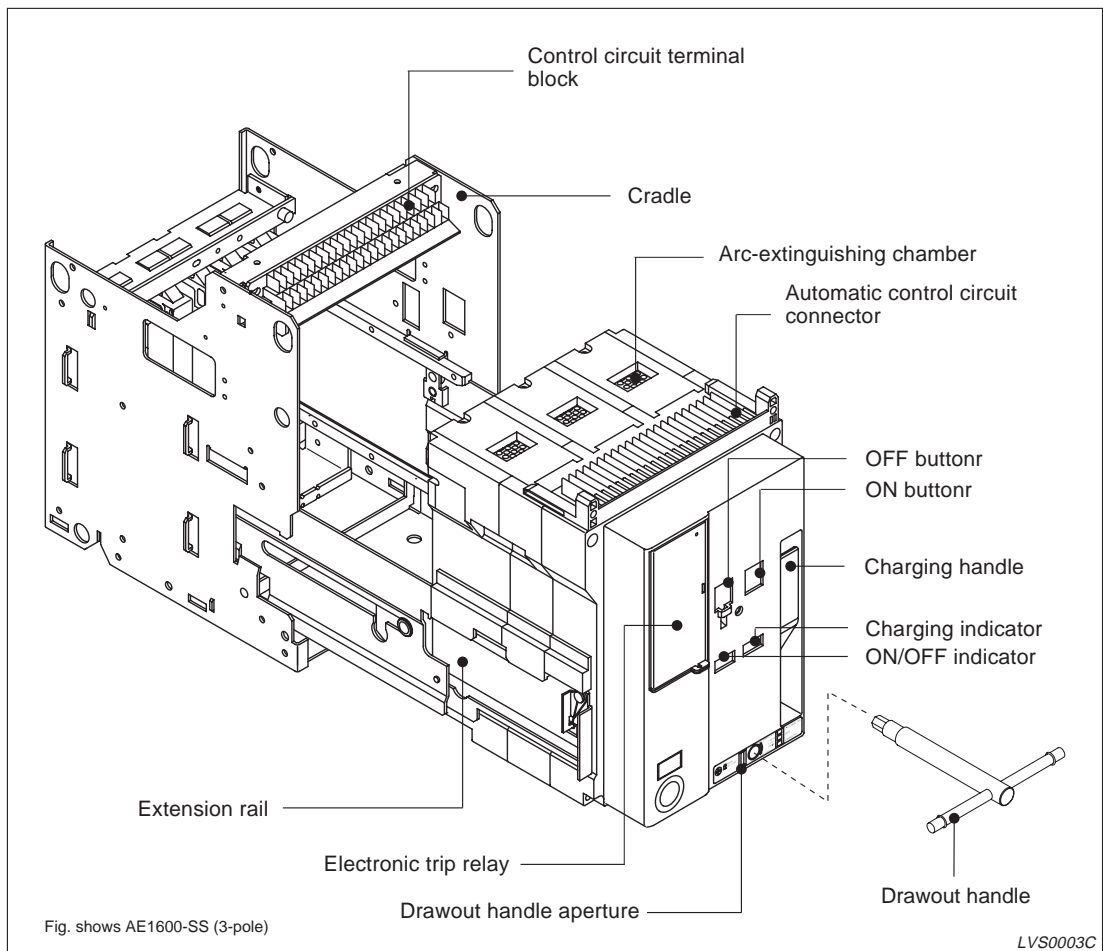

Fig. 1-3: Front view of the AE-SS

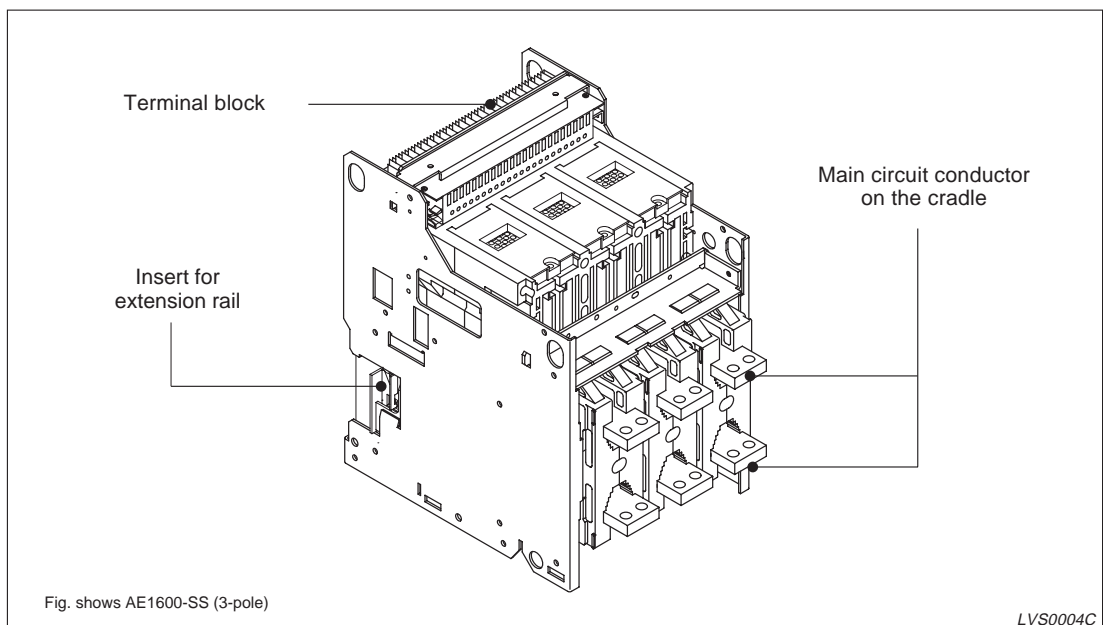

Fig. 1-4: Rear view of the AE-SS

1.1.3 AE1000–AE3200-SH – Drawout type

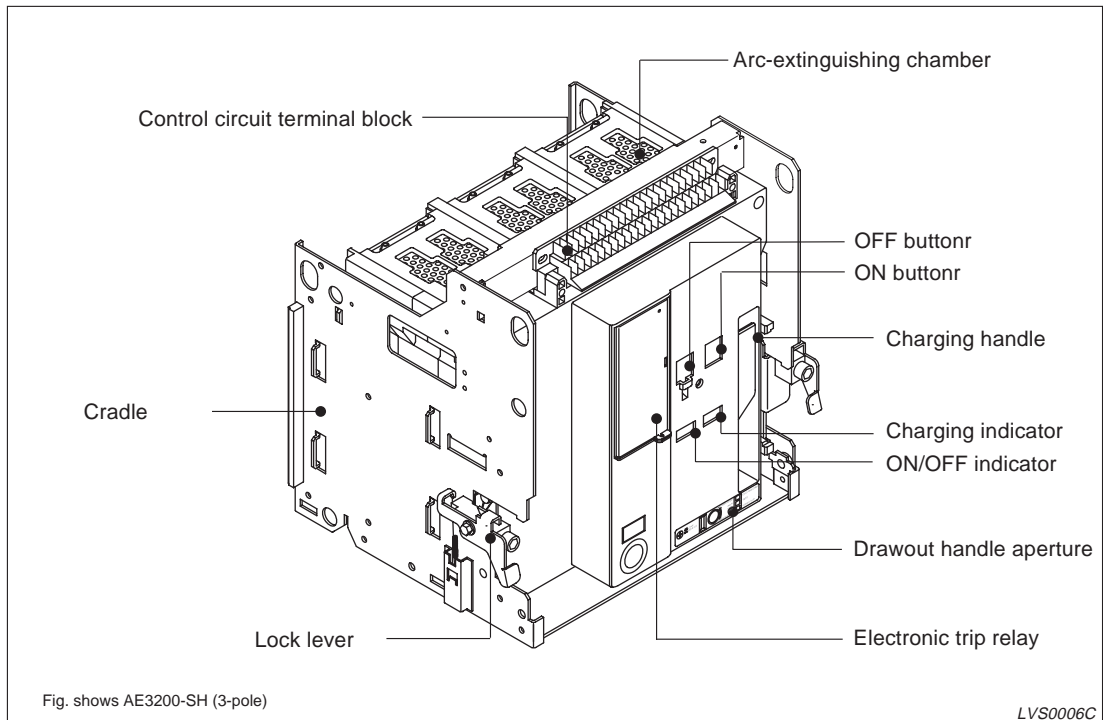

Fig. 1-6: Front view of the AE-SH

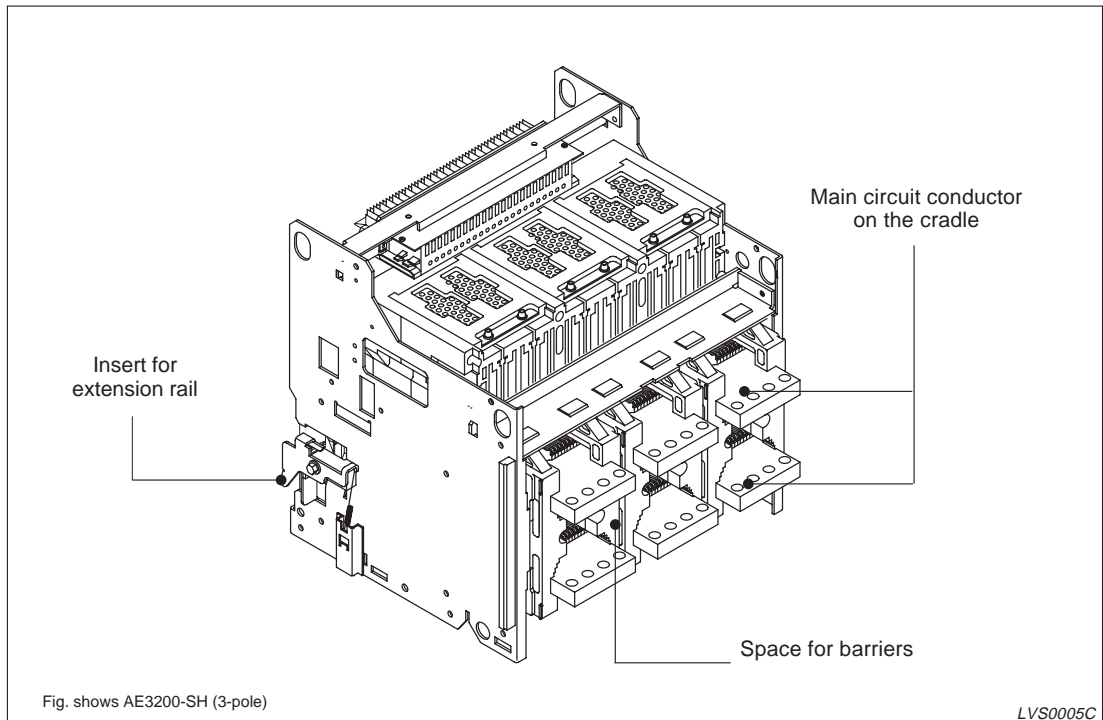

Fig. 1-5: Rear view of the AE-SH

1.1.4 AE4000–AE6300-SS – Drawout type

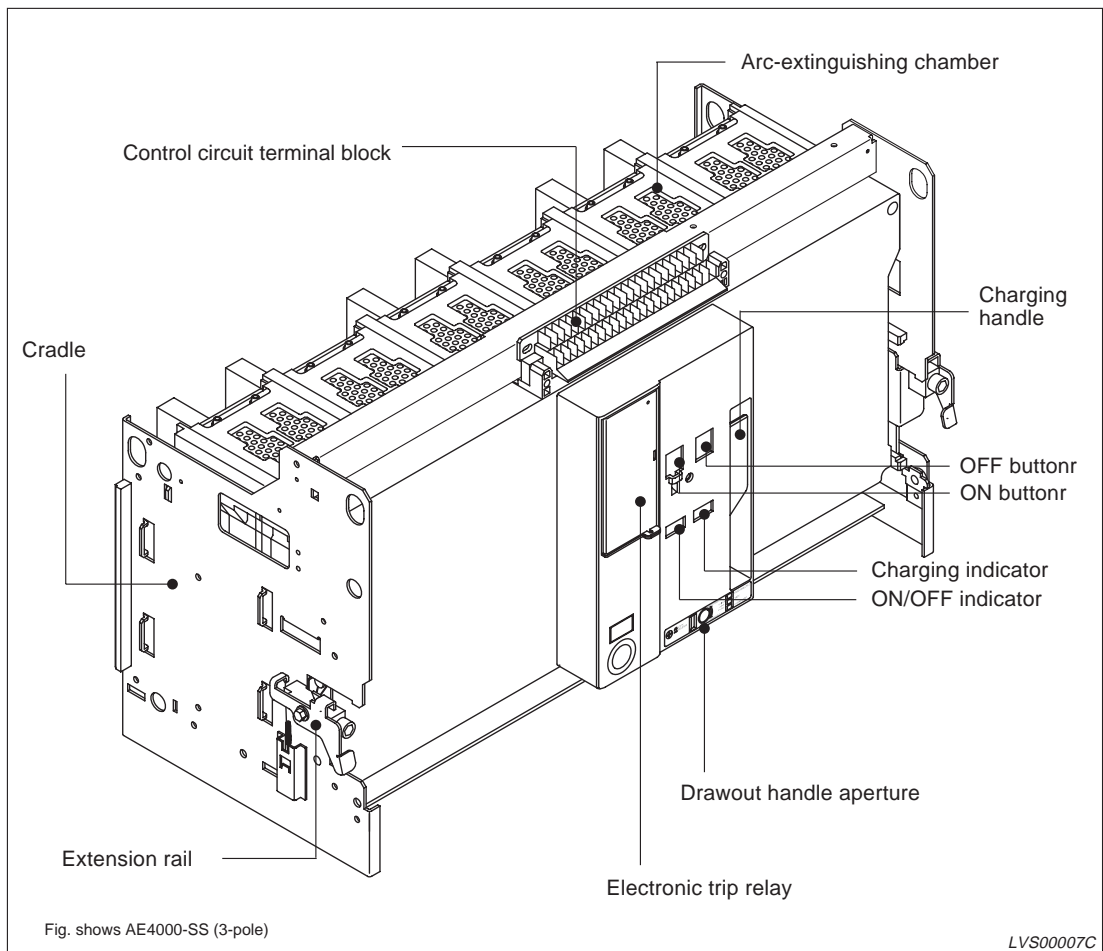

Fig. 1-7: Front view of the AE-SS

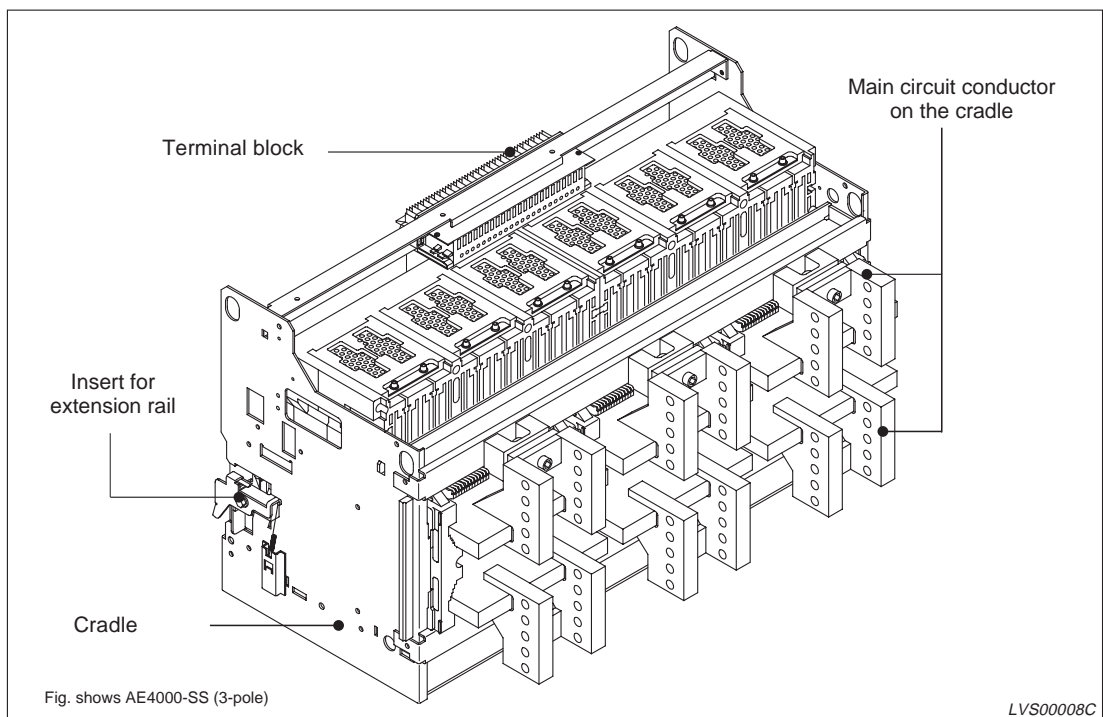

Fig. 1-8: Rear view of the AE-SS

1.2 Internal construction

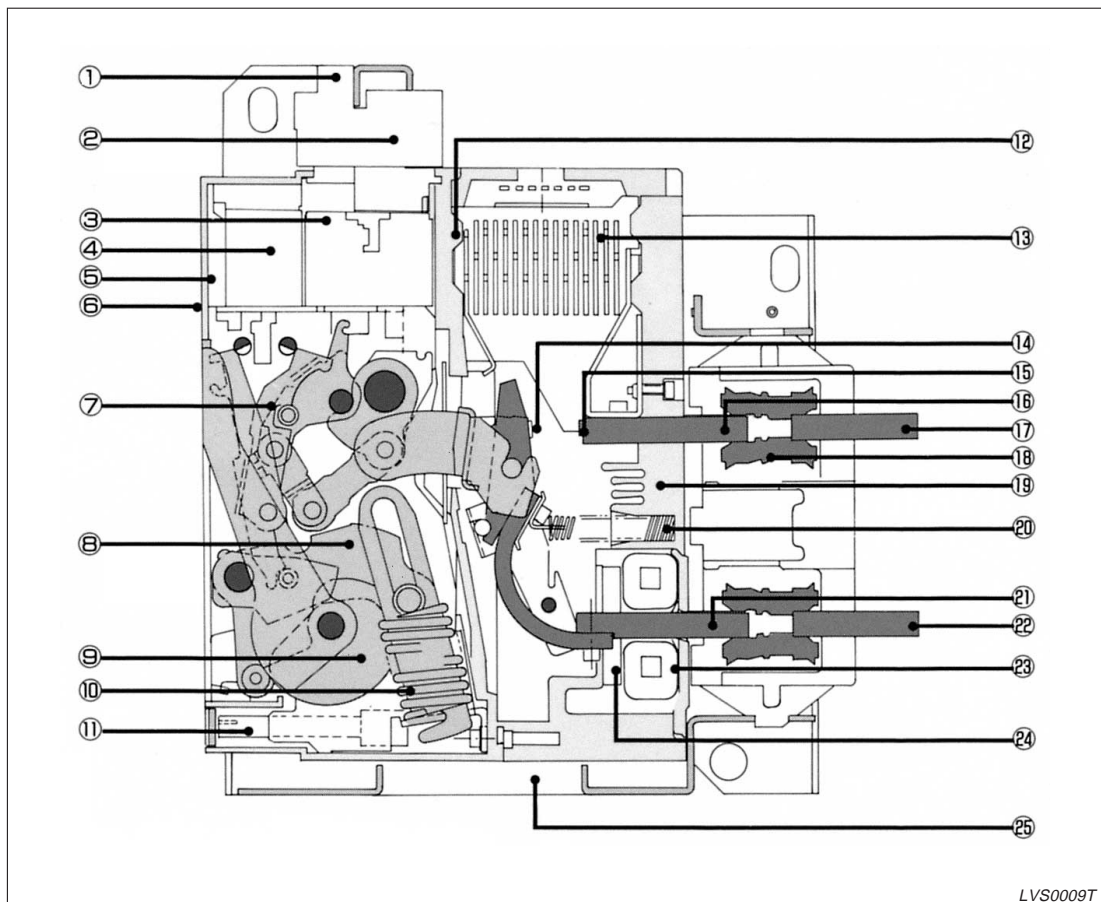

Fig. 1-9: Internal construction (principle)

Explanation to fig. 1-9

- | | |
|---------------------------------------|---|
| ① Control circuit terminal block | ⑭ Main movable contact |
| ② Automatic control circuit connector | ⑮ Main fixed contact |
| ③ Auxiliary switches | ⑯ Main circuit conductor on the breaker |
| ④ Shunt trip device, closing coil | ⑰ Main circuit conductor on the cradle |
| ⑤ Electronic trip relay | ⑱ Main circuit junction |
| ⑥ Front cover | ⑲ Base |
| ⑦ Tripping mechanism | ⑳ Contact spring |
| ⑧ Closing mechanism | ㉑ Main circuit conductor on the breaker |
| ⑨ Charging mechanism | ㉒ Main circuit conductor on the cradle |
| ⑩ Closing spring | ㉓ Power supply CT |
| ⑪ Drawout mechanism | ㉔ Current sensor coil |
| ⑫ Insulated base | ㉕ Cradle |
| ⑬ Arc-extinguishing chamber | |

2 Set-up

2.1 Unpacking

**CAUTION:**

If the breaker is lifted by hand take special care for the weight of the breaker (see sec. 2.4).

- ① Before unpacking, check whether the packing case is in correct condition.
- ② When unpacking, be careful not to damage or deform the cover, the terminals or other external parts.

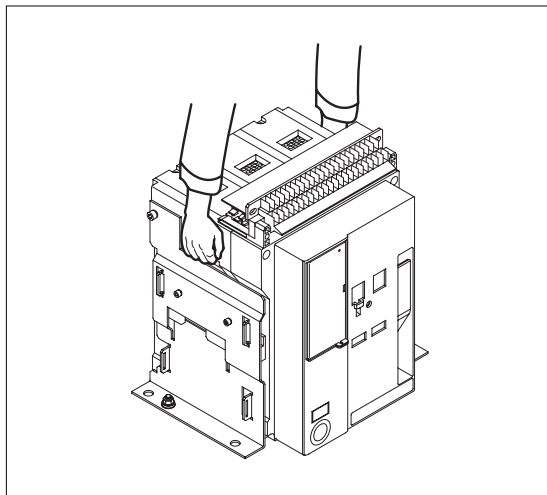

Fig. 2-1:
Unpacking the fixed types (up to AE1600)

LVS0010C

- ③ After unpacking, check whether the breaker is in correct condition or not.
- ④ Check whether the items described on the rating nameplate and accessory nameplate match those of the purchase order agree.
- ⑤ Remove the fixing plate (in case of the drawout type, see fig. 2-2).

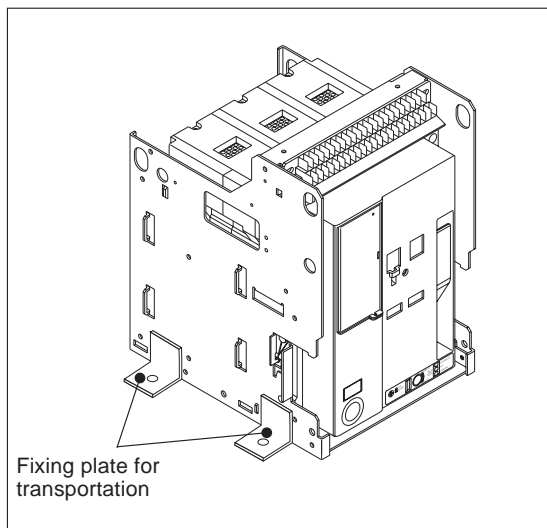

Fig. 2-2:
Drawout type

LVS0011C

2.2 Handling



CAUTION:

When lifting and placing, be careful neither to drop nor to impact the breaker and the terminals for the center of gravity is by the terminal.

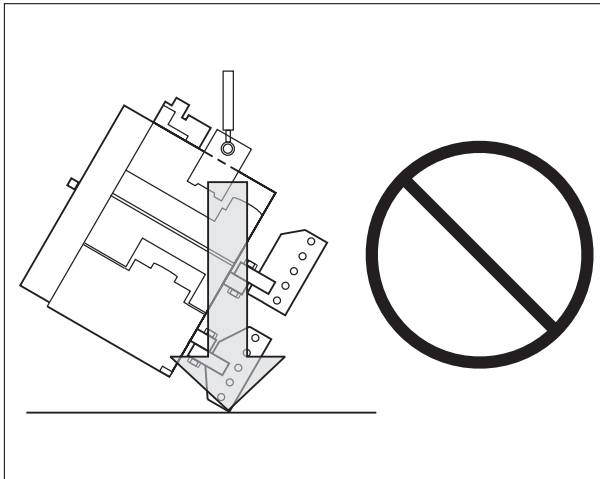

Fig. 2-3:

Der Schalter darf niemals auf den Hauptstromanschlüssen abgesetzt werden!

LVS0A13C



CAUTION:

Take extra care for the heavy weight of the breaker. Never slide the breaker when handling.

Fixed type

To lift the breaker (fixed type), use the lifting hooks on the sides of the breaker, and lift it with ropes or similar equipment.

When placing the breaker on the ground, be careful not to drop or to impact the breaker.

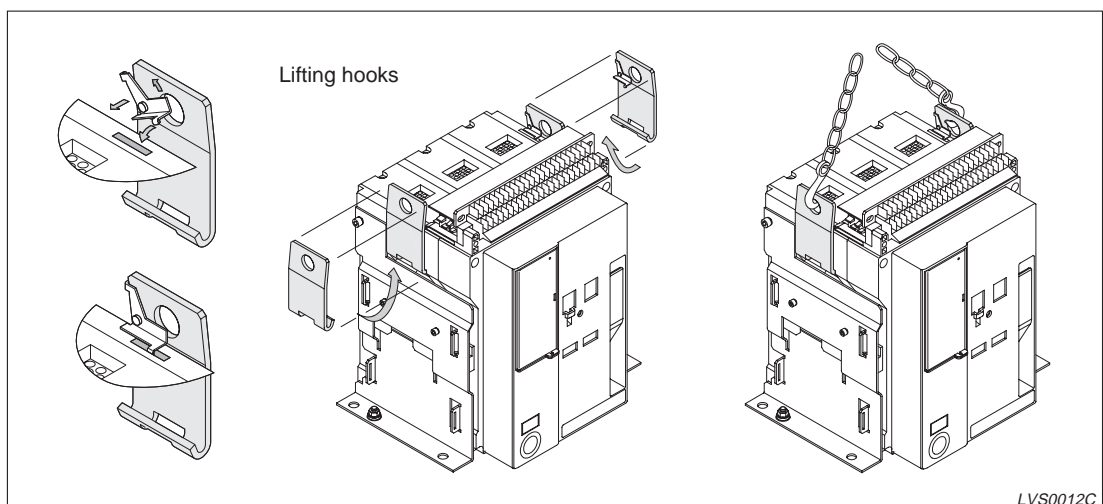

LVS0012C

Fig. 2-4: *Lifting the fixed type breaker*

Drawout type

To lift the breaker (drawout type), use the lifting holes on the sides of the breaker, and lift it with ropes or similar equipment. For the breakers AE4000–6300-SS you need ropes with a minimum length of 1 meter.

When placing the breaker on the ground, be careful not to drop or to impact the breaker. If you want to lift the drawout breaker with the cradle, lift it when it is in the connected position.

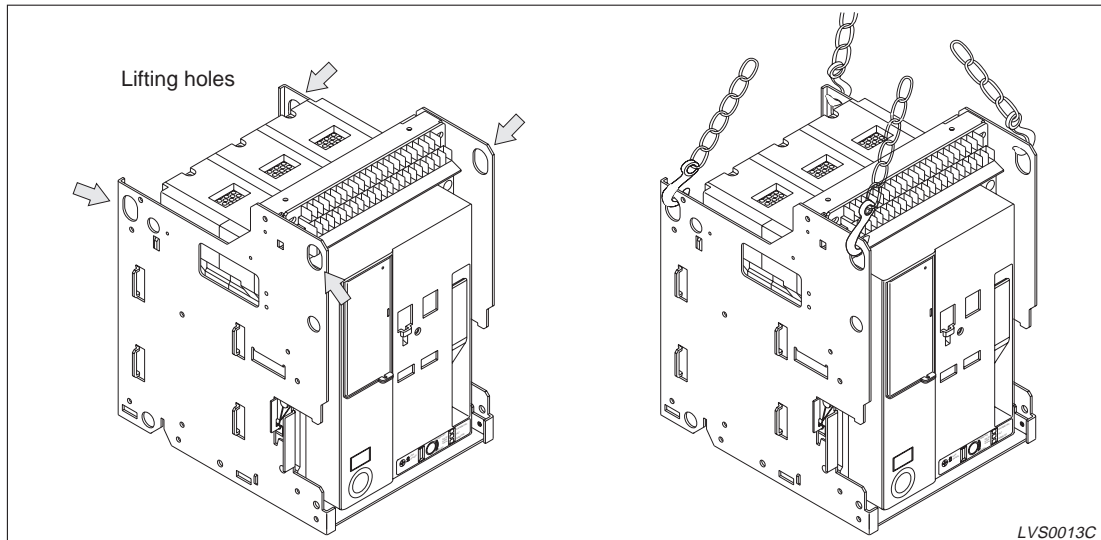

Fig. 2-5: Lifting the drawout type breaker

2.3 Dimensions

2.3.1 Fixed types AE1000–AE3200-SS/SH

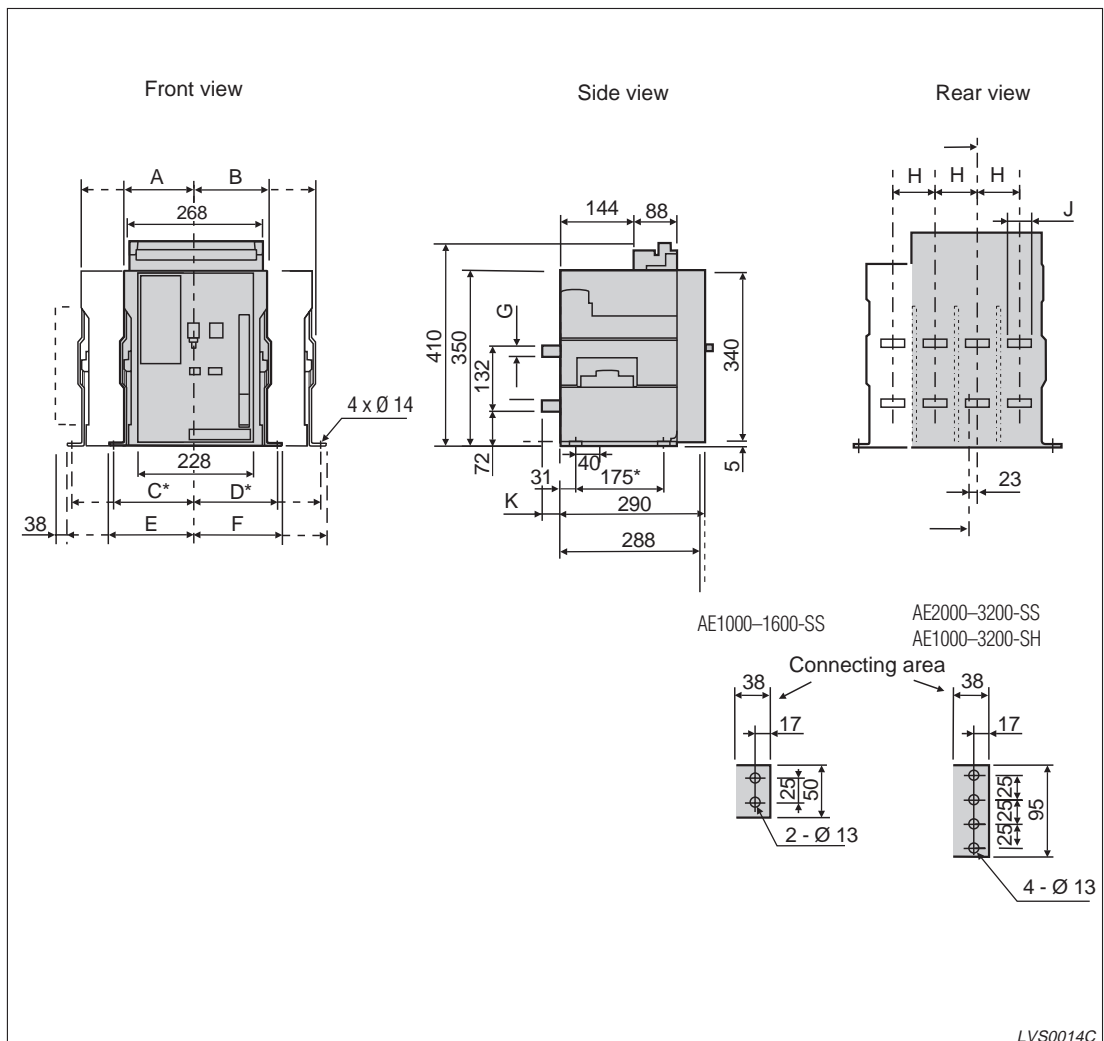

Fig. 2-6: Dimensions for fixed type breakers

| Type | Poles | A | B | C | D | E | F | G | H | J | K |
|------------------|-------|-----|-----|-----|-----|-----|-----|----|-----|----|----|
| AE1000 – 1600-SS | 3 | 142 | 142 | 156 | 156 | 170 | 170 | 15 | 85 | 50 | 40 |
| | 4 | 142 | 227 | 156 | 241 | 170 | 255 | 15 | 85 | 50 | 40 |
| AE2000 – 3200-SS | 3 | 232 | 187 | 246 | 201 | 260 | 215 | 20 | 130 | 95 | 40 |
| | 4 | 232 | 317 | 246 | 331 | 260 | 345 | 20 | 130 | 95 | 40 |
| AE1000 – 3200-SH | 3 | 232 | 187 | 246 | 201 | 260 | 215 | 20 | 130 | 95 | 70 |
| | 4 | 232 | 317 | 246 | 331 | 260 | 345 | 20 | 130 | 95 | 70 |

Tab. 2-1: Dimensions (in mm) for the above figure

2.3.2 Drawout types AE1000–AE3200-SS

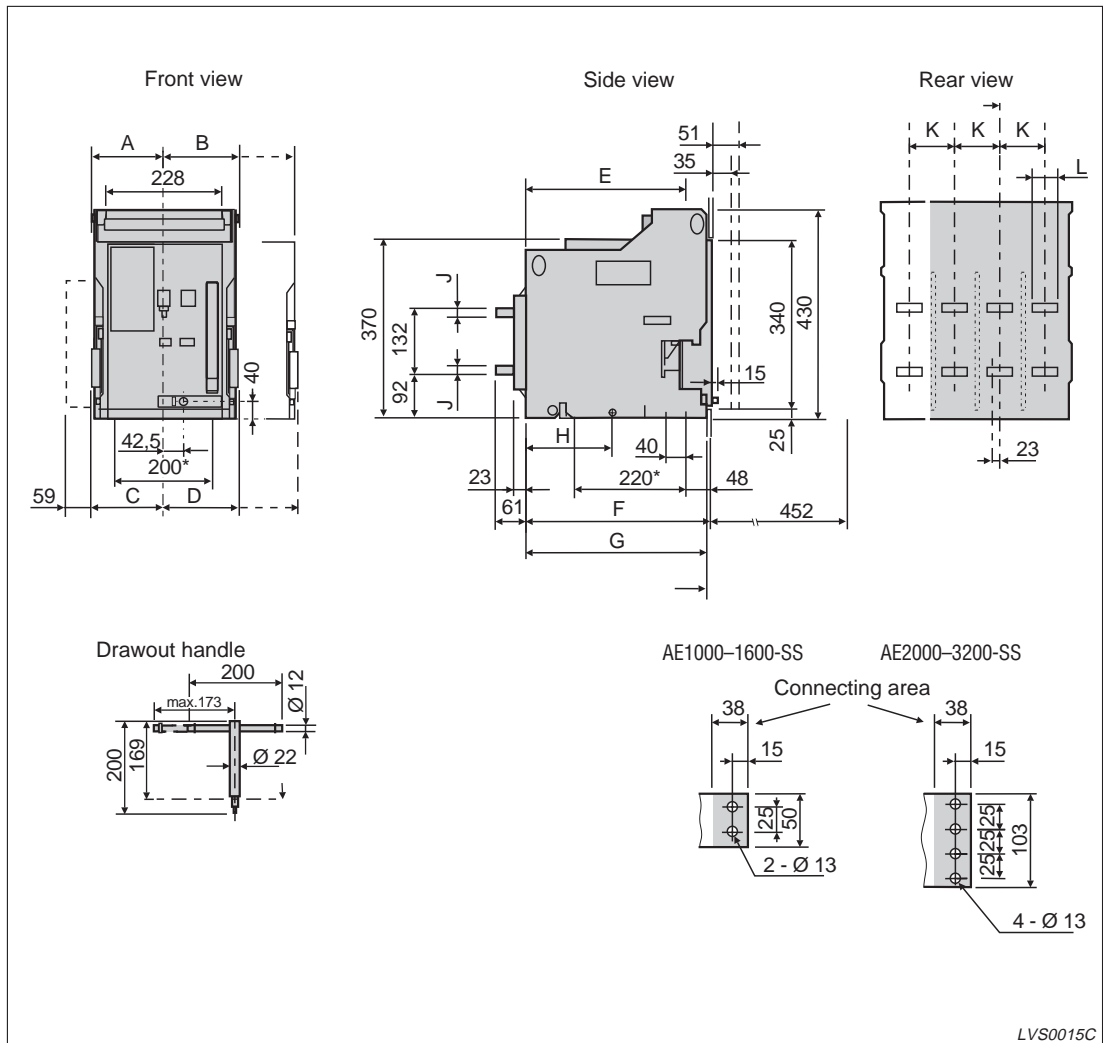

Fig. 2-7: Dimensions for drawout type breakers

| Type | Poles | A | B | C | D | E | F | G | H | J | K | L |
|------------------|-------|-----|-----|-----|-----|-----|-----|-----|-----|----|-----|-----|
| AE1000 – 1600-SS | 3 | 150 | 150 | 149 | 149 | 311 | 368 | 366 | 172 | 15 | 85 | 50 |
| | 4 | 150 | 235 | 149 | 234 | 311 | 368 | 366 | 172 | 15 | 85 | 50 |
| AE2000 – 3200-SS | 3 | 240 | 195 | 239 | 194 | 311 | 368 | 366 | 172 | 25 | 130 | 103 |
| | 4 | 240 | 325 | 239 | 324 | 311 | 368 | 366 | 172 | 25 | 130 | 103 |

Tab. 2-2: Dimensions (in mm) for the above figure

2.3.3 Drawout types AE1000–AE3200-SH

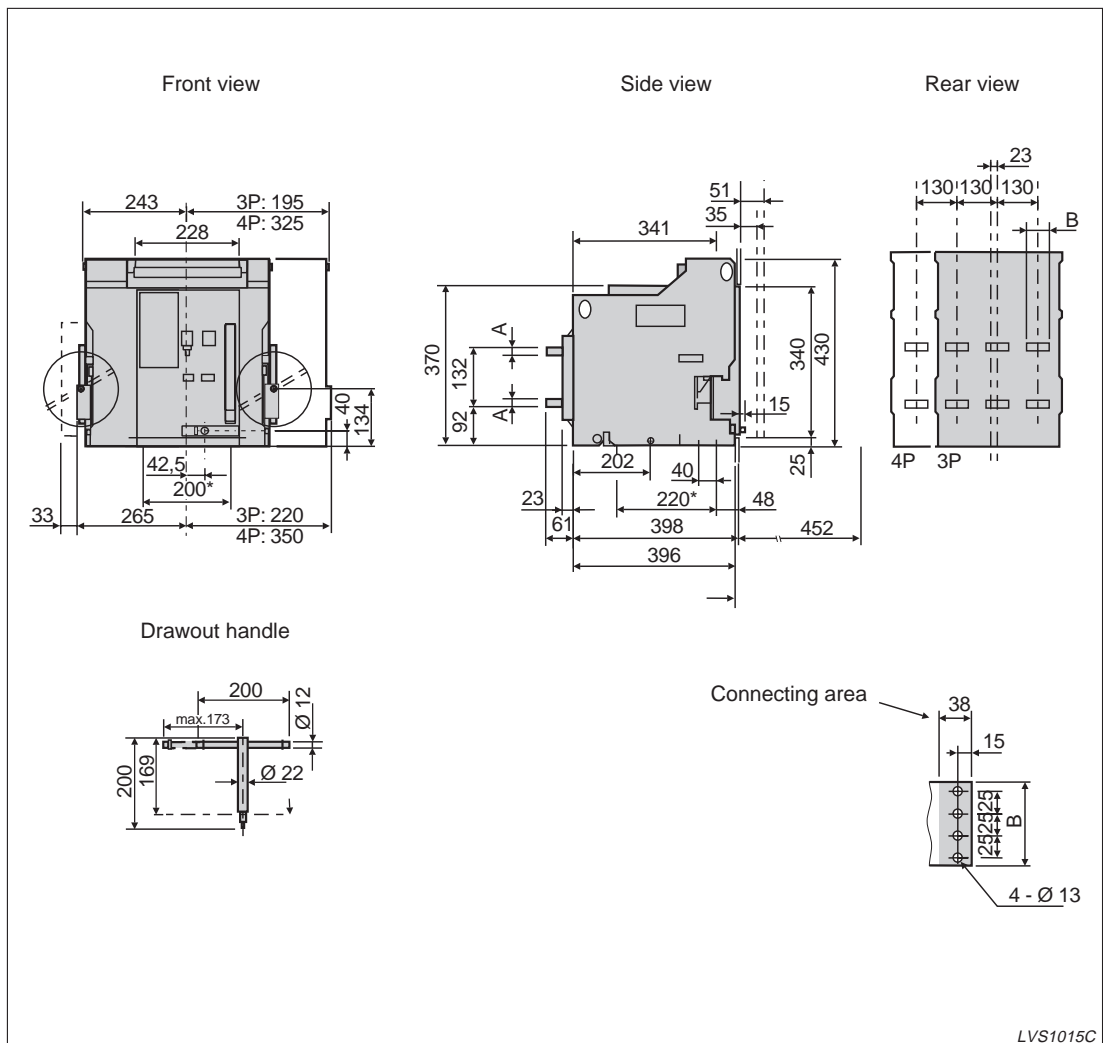

Fig. 2-8: Dimensions for drawout type breakers

2.3.4 Fixed types AE4000-SSA

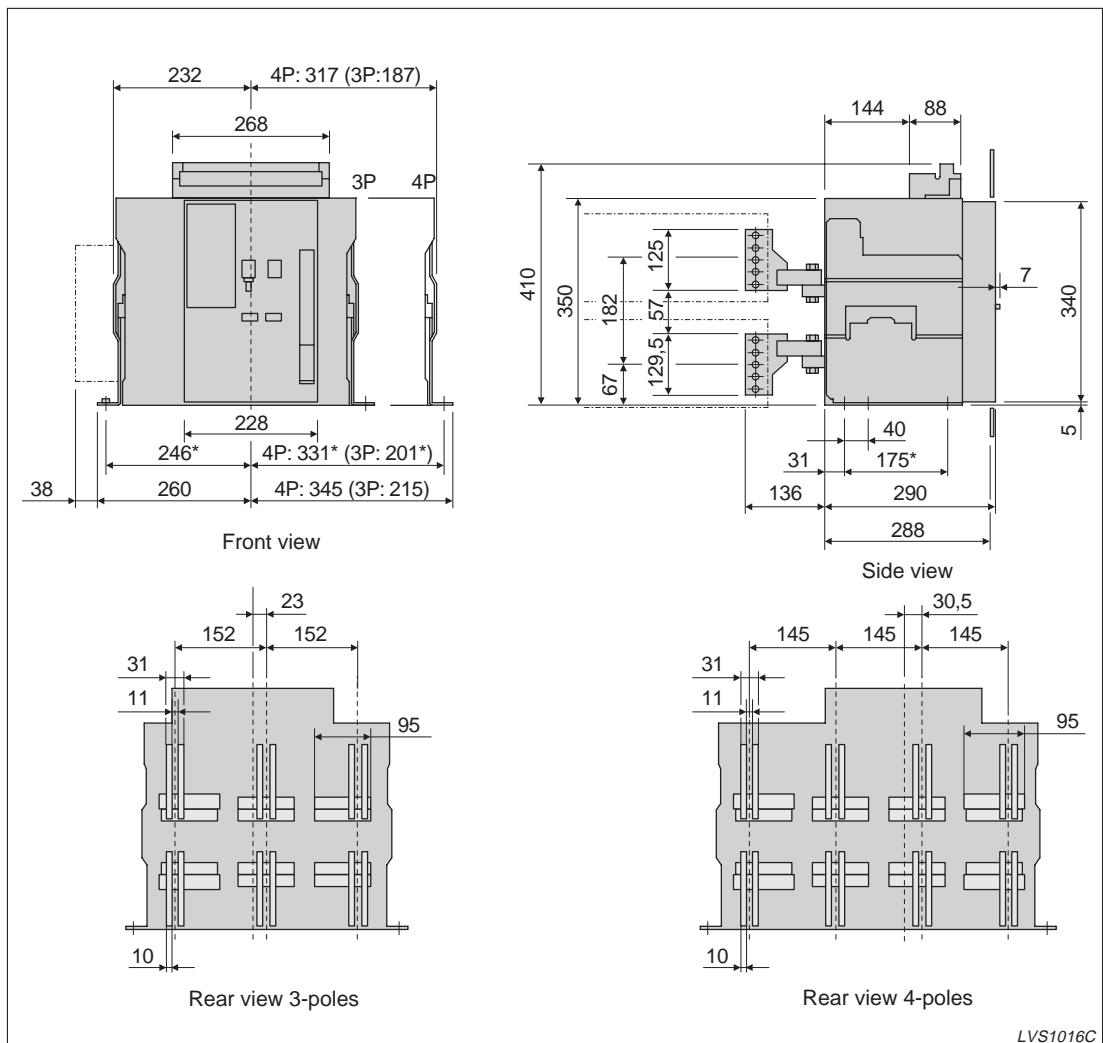

Fig. 2-9: Dimensions for drawout type breakers

LVS1016C

2.3.5 Drawout types AE4000-SSA

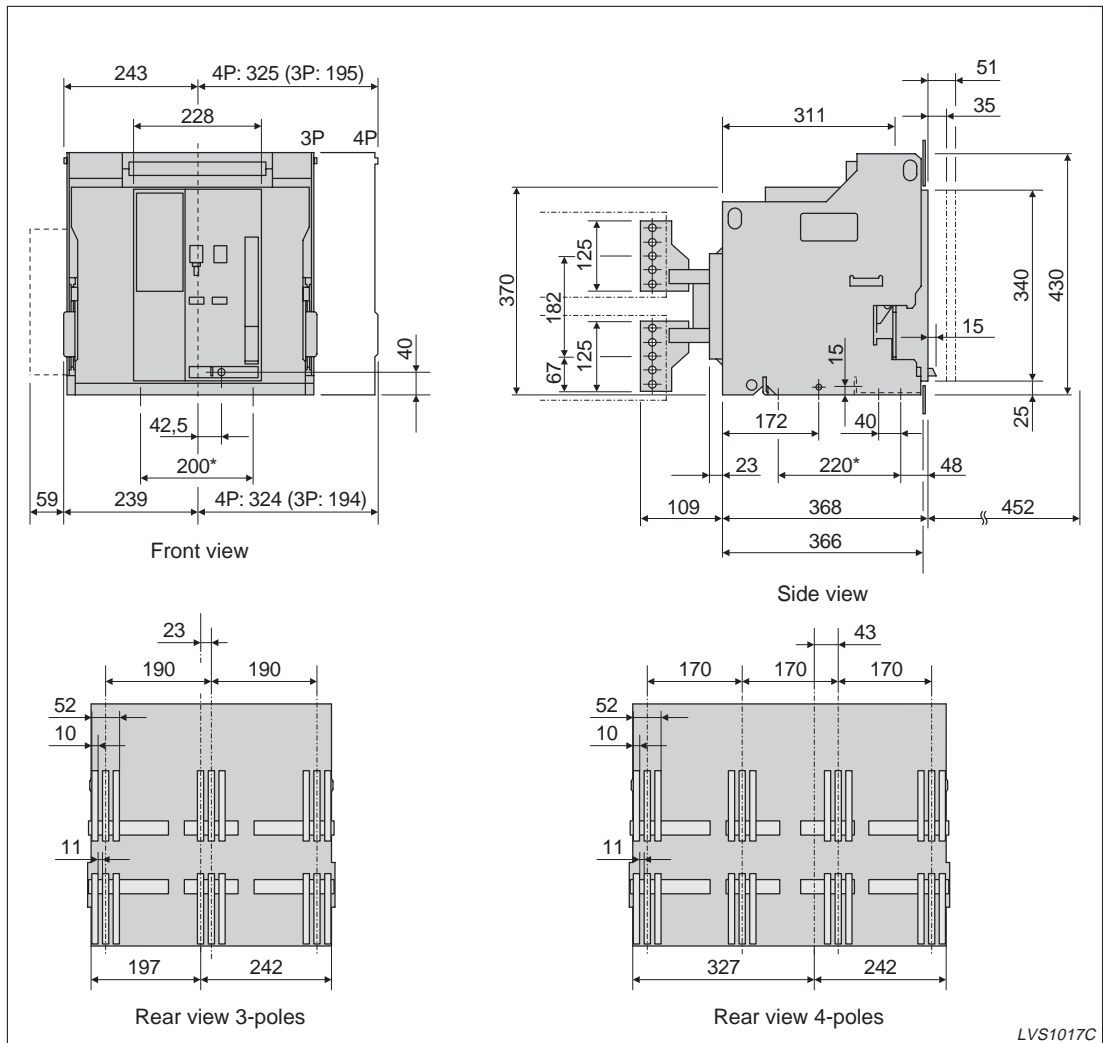

Fig. 2-10: Dimensions for drawout type breakers

LVS1017C

2.3.6 Fixed types AE4000-SSC

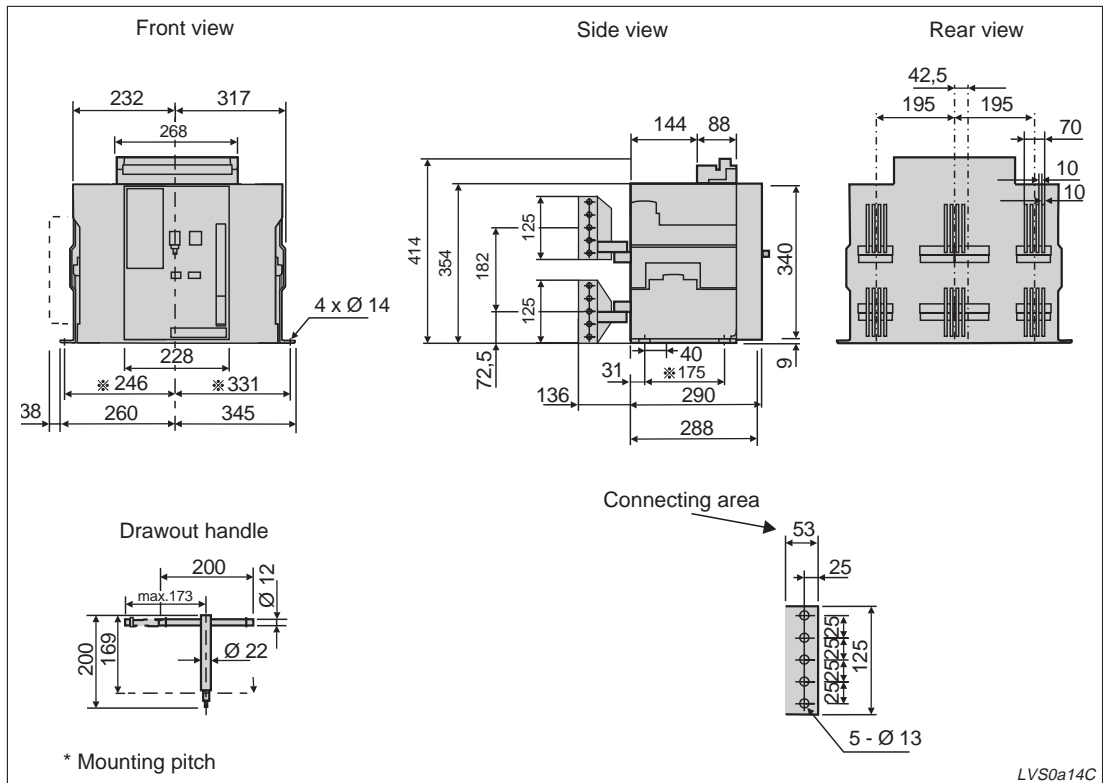

Fig. 2-11: Dimensions for fixed type breakers

2.3.7 Drawout types AE4000-SSC

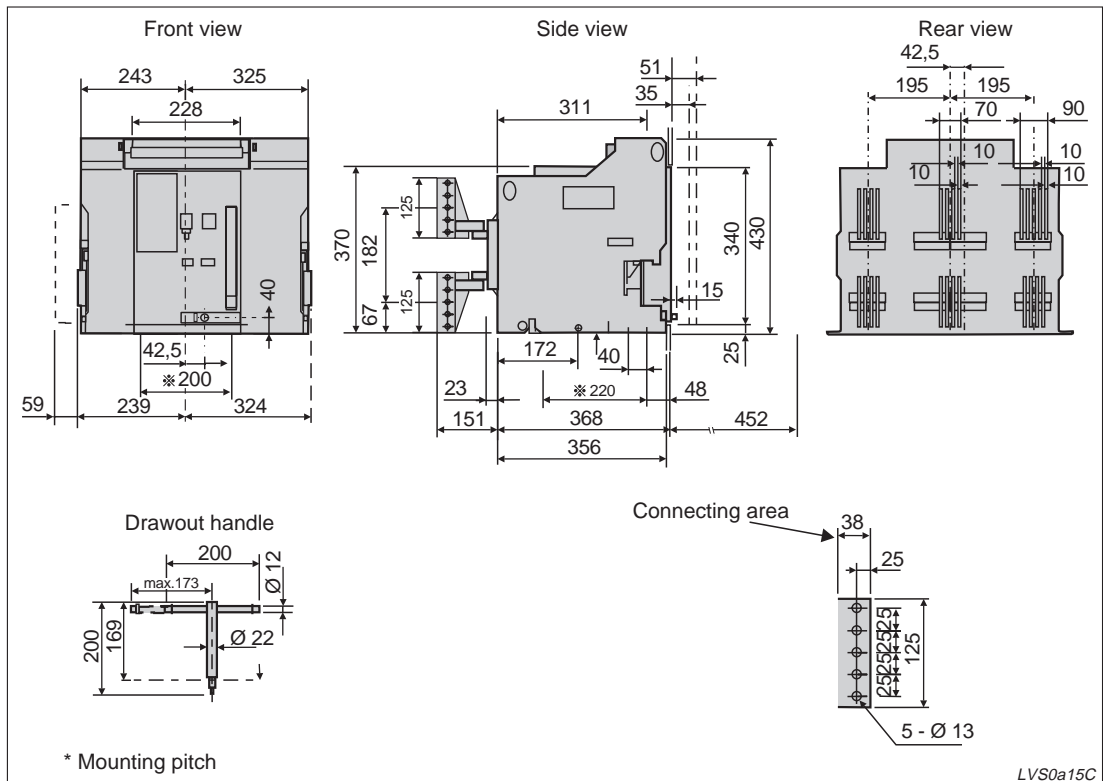
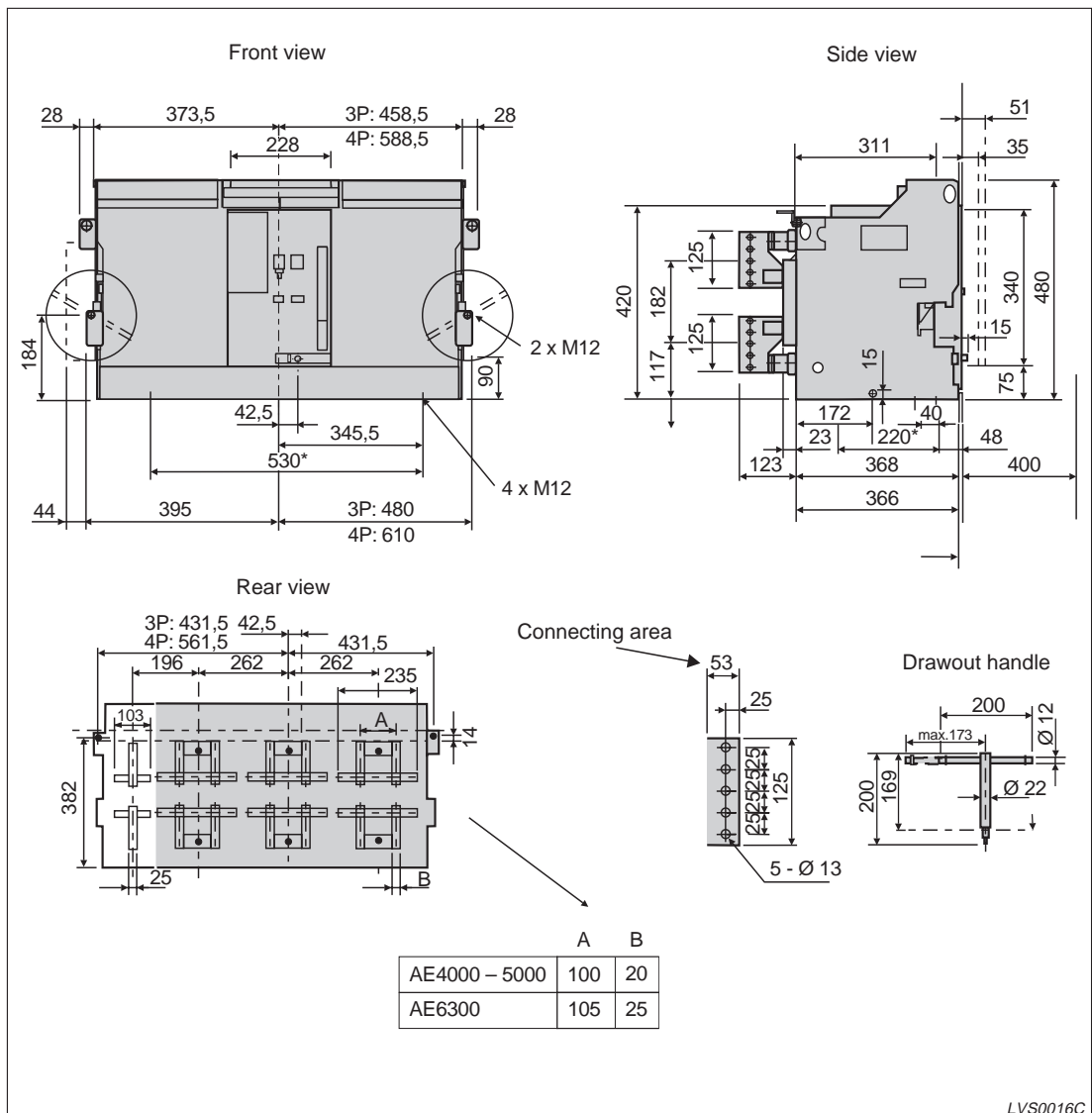

Fig. 2-12: Dimensions for drawout type breakers

2.3.8 Drawout types AE4000–AE6000-SS



LVS0016C

Fig. 2-13: Dimensions for drawout type breakers

2.4 Weight

2.4.1 Standard series

| Type | No. of poles | Fixed type | | Drawout type | | |
|------------|--------------|-----------------|----------------|-----------------|----------------|-------------|
| | | Manual charging | Motor charging | Manual charging | Motor charging | Cradle only |
| AE1000-SS | 3 | 41 | 44 | 64 | 67 | 26 |
| AE1250-SS | 4 | 51 | 54 | 78 | 81 | 30 |
| AE1600-SS | 3 | 42 | 45 | 65 | 68 | 26 |
| | 4 | 52 | 55 | 79 | 82 | 30 |
| AE2000-SS | 3 | 60 | 63 | 92 | 95 | 35 |
| | 4 | 72 | 75 | 113 | 116 | 43 |
| AE2500-SS | 3 | 61 | 64 | 93 | 96 | 35 |
| | 4 | 73 | 76 | 114 | 117 | 43 |
| AE3200-SS | 3 | 63 | 66 | 95 | 98 | 36 |
| | 4 | 75 | 78 | 116 | 119 | 44 |
| AE4000-SSA | 3 | 81 | 85 | 107 | 111 | 49 |
| | 4 | 99 | 103 | 136 | 140 | 61 |
| AE4000-SSC | 3 | 109 | 112 | 145 | 148 | 75 |
| AE4000-SS | 3 | — | — | 240 | 244 | 125 |
| | 4 | — | — | 263 | 267 | 140 |
| AE5000-SS | 3 | — | — | 240 | 244 | 125 |
| | 4 | — | — | 263 | 267 | 140 |
| AE6300-SS | 3 | — | — | 240 | 244 | 125 |
| | 4 | — | — | 263 | 267 | 140 |

Tab. 2-3: Weight (kg) SS types

2.4.2 High-performance series

| Type | No. of poles | Fixed type | | Drawout type | | |
|-----------|--------------|-----------------|----------------|-----------------|----------------|-------------|
| | | Manual charging | Motor charging | Manual charging | Motor charging | Cradle only |
| AE1000-SH | 3 | 66 | 69 | 105 | 108 | 42 |
| AE1250-SH | 4 | 79 | 82 | 127 | 130 | 50 |
| AE1600-SH | 3 | 66 | 69 | 105 | 108 | 42 |
| | 4 | 79 | 82 | 127 | 130 | 50 |
| AE2000-SH | 3 | 66 | 69 | 105 | 108 | 42 |
| | 4 | 79 | 82 | 127 | 130 | 50 |
| AE2500-SH | 3 | 66 | 69 | 105 | 108 | 42 |
| | 4 | 79 | 82 | 127 | 130 | 50 |
| AE3200-SH | 3 | 66 | 71 | 107 | 110 | 43 |
| | 4 | 79 | 84 | 129 | 132 | 51 |

Tab. 2-4: Weight (kg) SH types

2.5 Storage

Long term storage of the breaker

To store the breaker, a dust free and dry environment is required.



CAUTION:

When storing, keep the breaker in the OFF position with the charging spring discharged as shown in fig. 2-14.

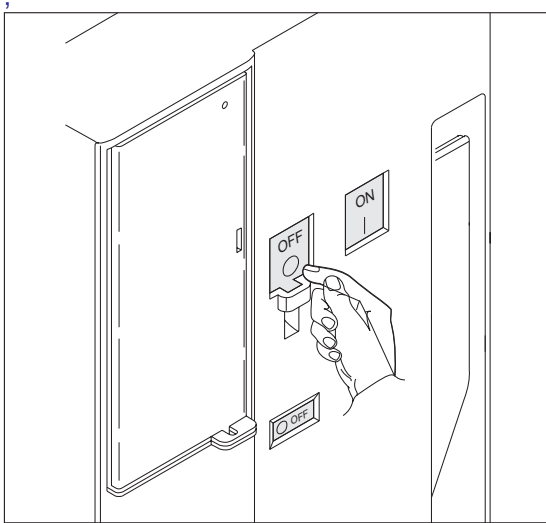

Fig. 2-14:

Keep the breaker in the OFF position before storing the breaker

LVS0018C

Check the OFF and DISCHARGED indicators.

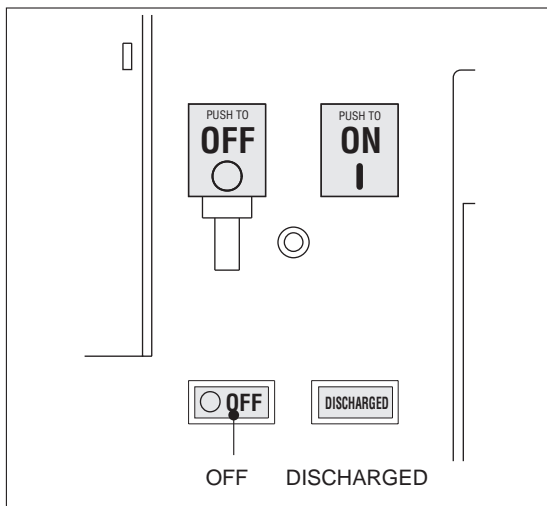

Fig. 2-15:

OFF and DISCHARGED indicators

LVS0019C

When storing, cover the breaker with a vinyl sheet or a similar cover.

When placing the breaker in service after storage, it is unnecessary to lubricate the parts of the breakers.

2.6 Installation

2.6.1 Fixed types

If you have an unmounted breaker due to service or maintenance, securely install the left and right mounting frames with two bolts M6 and one bolt M8 each (at delivery the breakers are mounted to the frame).

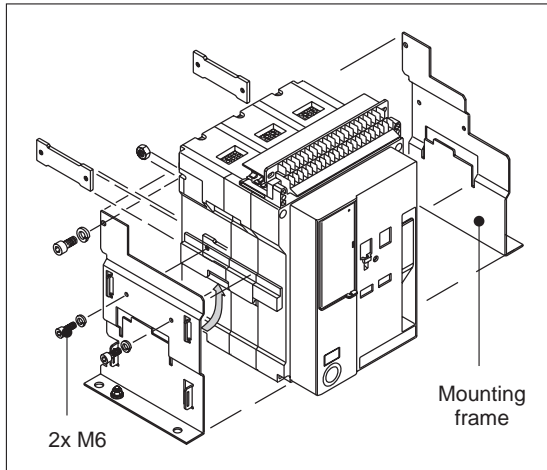

Fig. 2-16:
Mounting the frames

LVS0020C

The bolt on the side of the frame is for the wiring of the earth cable. The mounting hole on the bottom of the frame are for fixing the breaker to a secure stand..

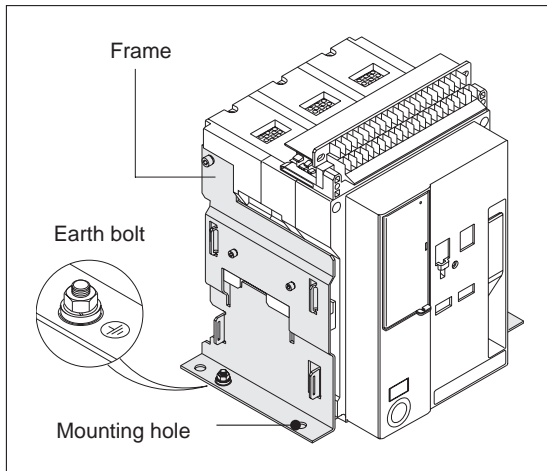

Fig. 2-17:
Assembled fixed type breaker

LVS0021C

For fixing the breaker on a plain surface use M12 bolts.

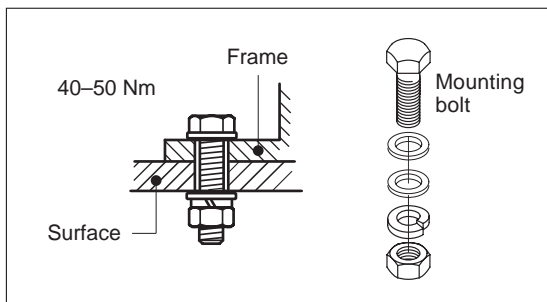

Fig. 2-18:
Fixing the breaker

LVS0022C

2.6.2 Drawout type

NOTE

For details on the operation of the drawout mechanism refer to sec. 2.11.

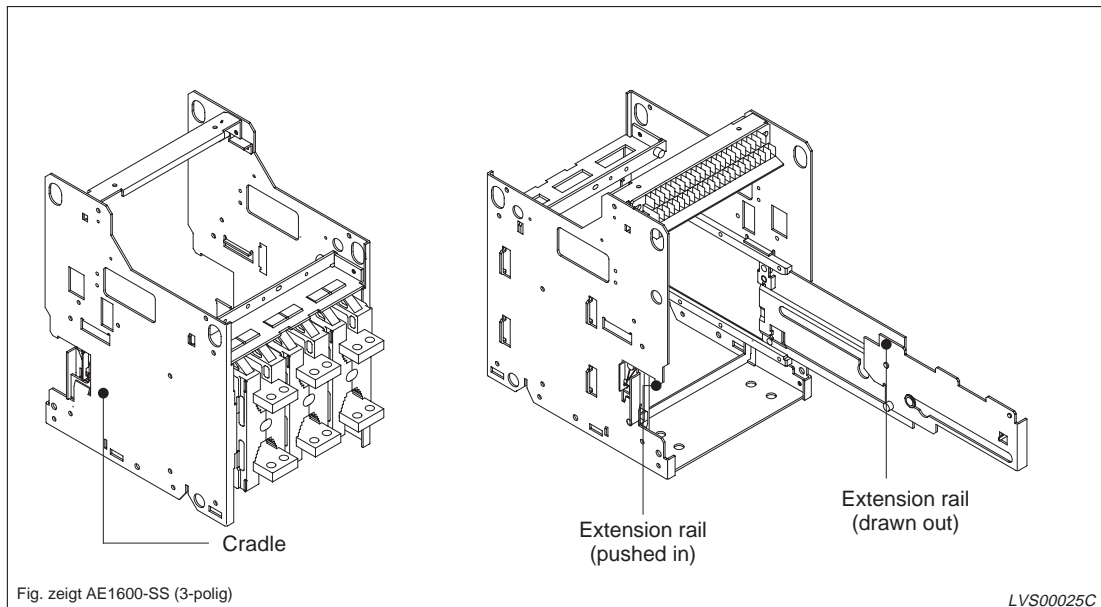

Fig. 2-19: Mounting the cradle

When delivered, the breaker is inserted into the cradle. To mount the cradle draw out the breaker from the cradle and mount the cradle in the panel as described in the following way:

- ① Remove the two fixing bolts (M12) on the left and right side of the extension rail. This applies to the AE-SH series and AE4000–6300-SS (see fig. 2-20).

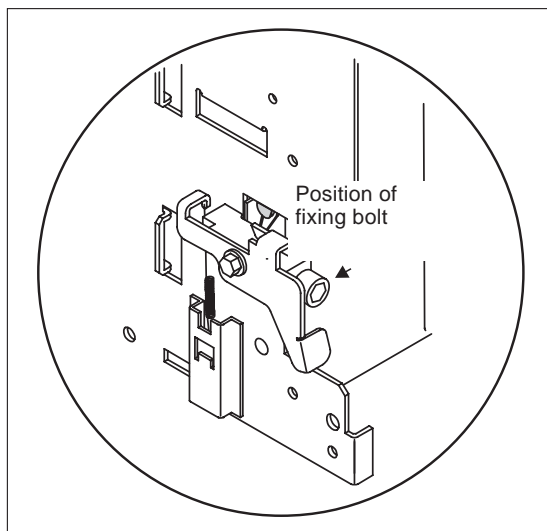

Fig. 2-20:
Position of fixing bolt at AE-SH series and breakers AE4000–6300-SS

LVS0027C

NOTE

To draw the breaker AE4000–6300-SS, pull each side equal speed. Otherwise (in the case of drawing one side) the breaker can not move smoothly.

- ② Keeping the OFF button pushed, insert the drawout handle into its aperture.

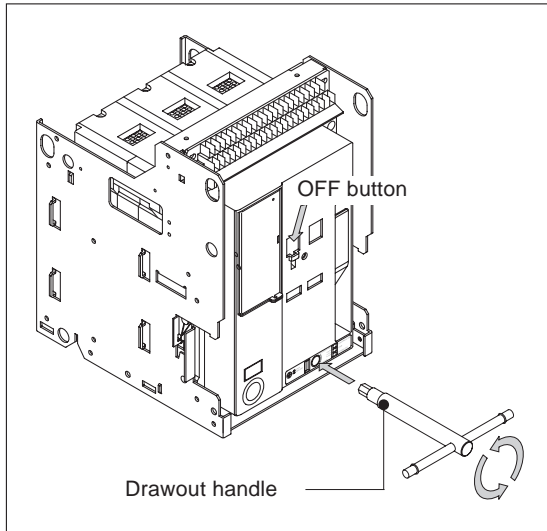

Fig. 2-21:
Handling the drawout handle

LVS0024C

NOTE

Unless the OFF button is pushed, the drawout handle cannot be inserted.

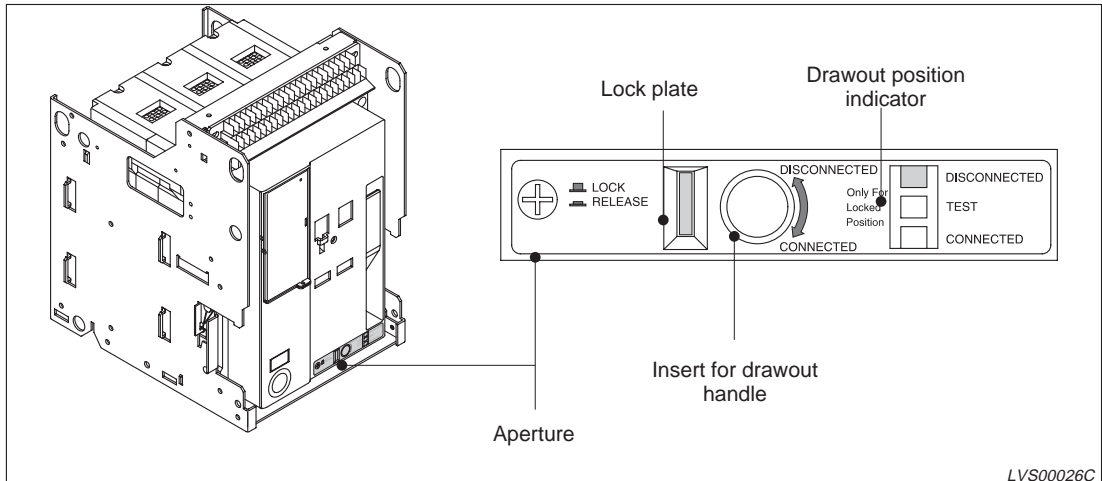

Fig. 2-22: Drawout handle aperture

LVS00026C

- ③ When the lock plate is projecting, push the lock plate in fully until it is latched in order to release the lock. Then, after releasing the lock plate, turn the drawout handle counterclockwise until the drawout handle is automatically locked (the lock plate will again be projecting) and the drawout position indicator will show the TEST position.

NOTE

If lock plate is blocked, slightly turn the drawout handle clockwise.

Be sure to push the lock plate in fully to the latched position, or the drawout position indicator will not function correctly.

- ④ Push in the lock plate, continuously turning the drawout handle further until the drawout position indicator shows the DISCONNECTED position. The handle operation is done until the breaker does not move, the breaker can be drawn out by hand.

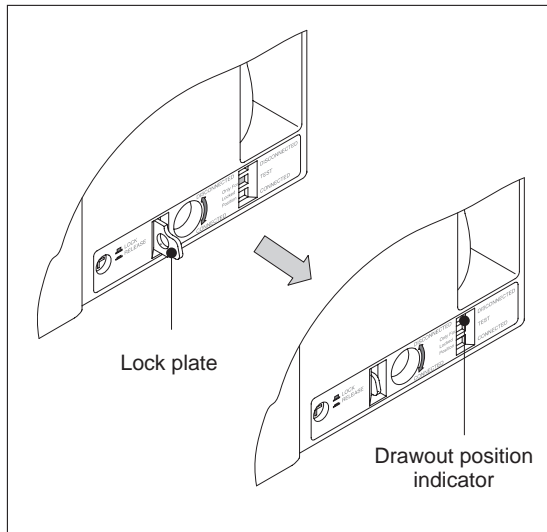

Fig. 2-23:
Details of the drawout handle aperture

LVS0032C

NOTE

The lock plate may project before the breaker moves to the DISCONNECTED position. In this case, push the lock plate in and continue to operate the handle.

If the lock plate is blocked, slightly turn the drawout handle clockwise.

- ⑤ Pull out the lock lever and pull the extension rail forward. At this point, the breaker will be drawn out. To draw the breaker, pull each side equal speed. Otherwise (in case of drawing one side) the breaker can not move smoothly.



CAUTION:

Since the center of gravity moves forward when the breaker is drawn out, take care to prevent it from falling.

NOTE

For the breakers AE4000 to AE6000 the center of gravity is by the terminals. If the cradle is not fixed, a cradle support is required to prevent it from falling when the breaker is removed from the cradle.

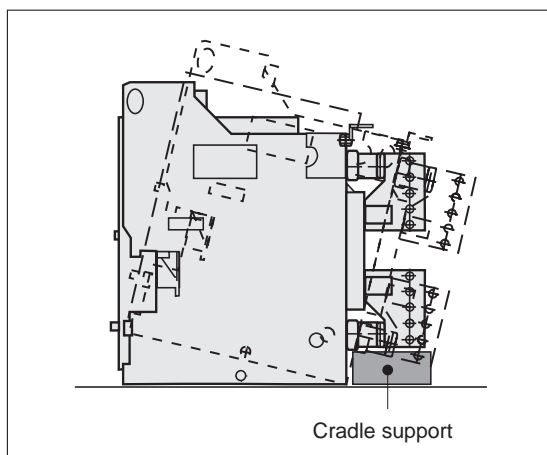

Fig. 2-24:
Cradle support for AE4000 to AE6300

LVS0032C

- ⑥ Remove the breaker from the cradle (for the method of lifting, refer to sec. 2-2).

- ⑦ As shown in fig. 2-25, insert four M12 bolts from above to mount the cradle. In case of AE4000 to AE6300, insert four M12 bolts from below and two M12 bolts from back.

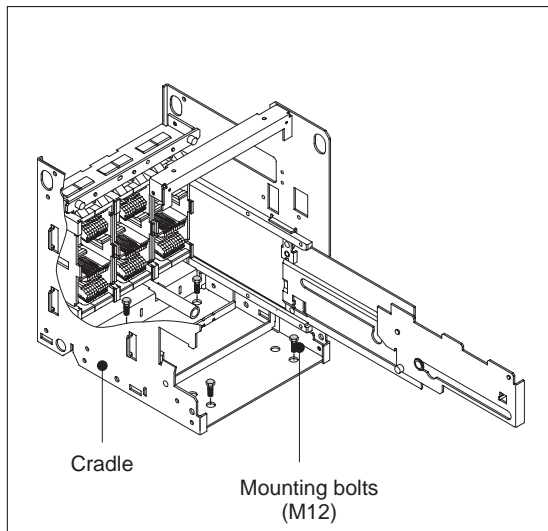

Fig. 2-25:
Mounting the cradle

LVS0032C

NOTES

When the bolts are inserted from the back side of the bottom due to contacting the breaker and the head of the bolts, the breaker cannot be moved.

The breaker must be installed on a level base to ensure that it can be drawn in and out easily. The planeness must be up to 2 mm.

Holder for the drawout handle

The drawout type breakers are delivered with a holder for the drawout handle. Mount the holder for the drawout handle after the installation of the breaker as shown in the following figure.

NOTES

The handle holder can be mounted on the right side plate of the cradle to keep the drawout handle in secure place.

The handle holder cannot be mounted on the cradle with mechanical interlock (MI) or with a door interlock (DI).

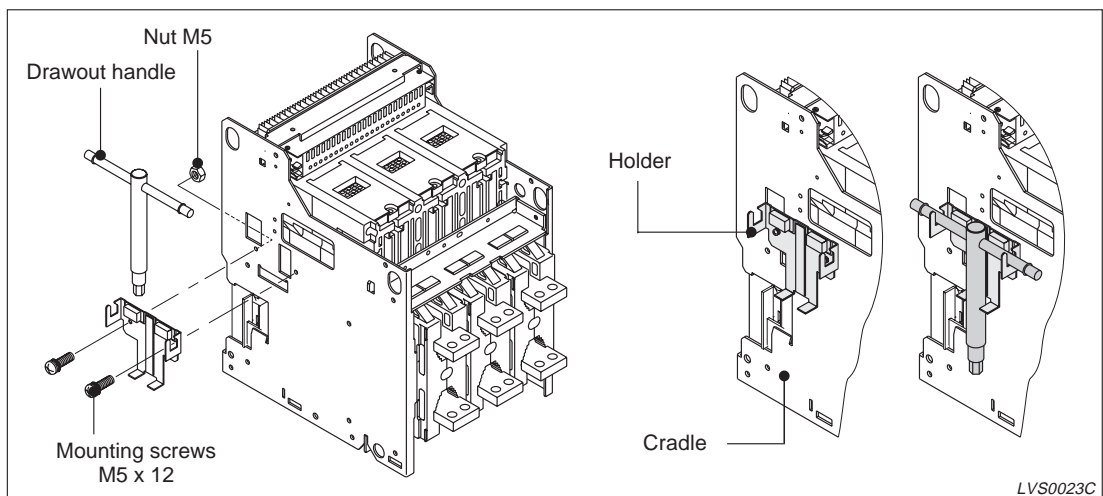

Fig. 2-26: Mounting the drawout handle

LVS0023C

2.7 Connections

Use M12 bolts plus washers and spring washers for the terminal connections.



CAUTION:

Unless conductors are not securely connected at the specified torque, operation of the breaker may result in fire. Also ensure that the washers are flat when connecting the bus bars.

2.7.1 Main connectors

In order to prevent an increasing contact resistance owing to humidity, plating silver to the contact surface of the conductor which is connected to the terminal of the breaker is recommended. Also clean the contact surface, and securely connect the conductors at a suitable torque.

| Screw size | Tightening torque (Nm) |
|------------|------------------------|
| M12 | 40 – 50 |

Tab. 2-5:

Standard tightening torque

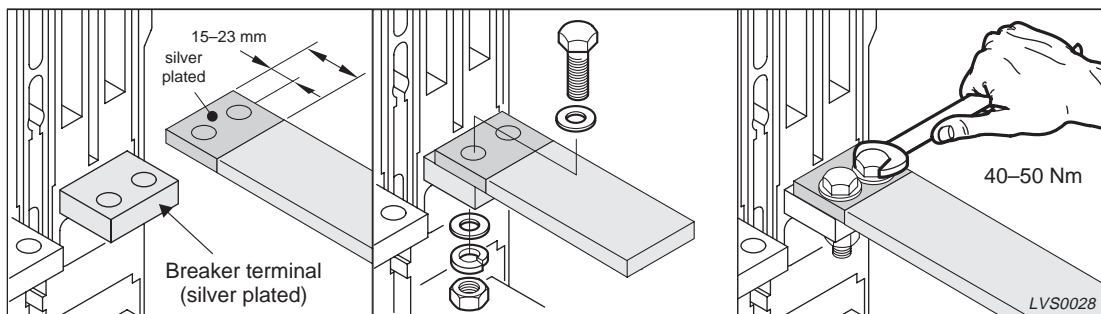

Fig. 2-27: Connection example

Since fault current flowing through the connection conductors causes enormous electromagnetic forces, the conductors should be secured firmly, using the values shown in table 2-5.

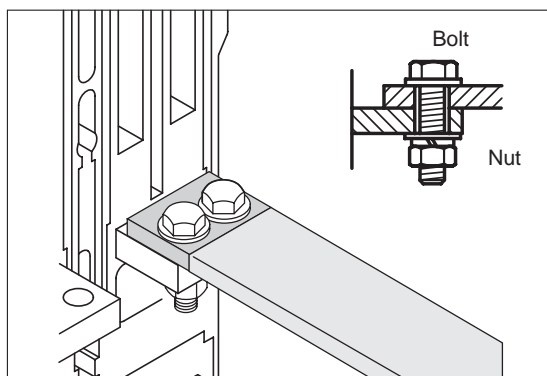

Fig. 2-28:

Connection of the bolts and nuts

LVS0029C

The maximum busbar supporting distance nearest to ACB is less than 200 mm (refer to following figure).

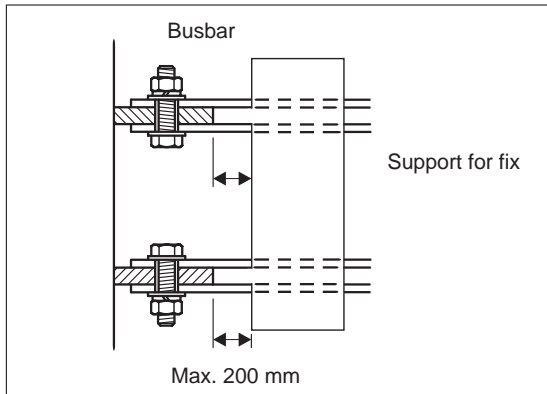

Fig. 2-29:
Busbar supporting distance

LVS0030C

The connection pitch between two bolts is 25 mm. Ensure the washers are flat when connecting the bus bars.

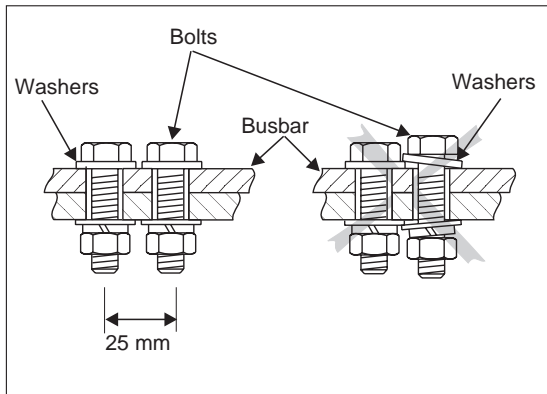

Fig. 2-30:
Bolts pitch and correct mounting method

LVS00196

2.7.2 Electromagnetic force

CAUTION:

Attach the conductors securely to ensure the electromagnetic force cannot cause short circuit accidents.

| Type (A) | AE1000– AE1600-SS | AE2000– AE3200-SS/SH | AE4000-SSA | | | | AE4000-SSC | AE4000– AE6300-SS |
|--|----------------------|-------------------------|------------|------|------|------|------------|----------------------|
| Conductor distance (mm) | 85 | 130 | D/O | | Fix | | 195 | 262 |
| | | | 3P | 4P | 3P | 4P | | |
| Prospective fault current kA (cosφ) | | | 190 | 170 | 152 | 145 | | |
| 30 (0.2) | 750 | 450 | 340 | 380 | 420 | 420 | 340 | 230 |
| 42 (0.2) | 1460 | 890 | 690 | 750 | 840 | 840 | 670 | 450 |
| 50 (0.2) | 2080 | 1250 | 960 | 1060 | 1180 | 1180 | 940 | 630 |
| 65 (0.2) | 3510 | 2120 | 1630 | 1800 | 2000 | 2000 | 1590 | 1060 |
| 85 (0.2) | 6020 | 3620 | 2790 | 3070 | 3400 | 3400 | 2720 | 1810 |
| 100 (0.2) | — | 5010 | — | — | — | — | — | 2510 |
| 130 (0.2) | — | 8470 | — | — | — | — | — | 4240 |

Tab. 2-6: Electromagnetic force in kg per 1 m of conductor (in case of a three phase short circuit)

Connection conductor size

When selecting conductors for a connection to a AE series breaker, ensure that they have a sufficient current capacity according to the values shown in following table.

| Rated current max. (A) | Connecting conductors (copper bus bar) | | |
|---------------------------|--|---------------|---------------------|
| | Arrangement | Quantity | Conductor size (mm) |
| 1000 | with long surface vertical | 2 | 60 x 5 |
| 1250 | with long surface vertical | 2 | 80 x 5 |
| 1600 | with long surface vertical | 2 | 100 x 5 |
| 2000 | with long surface vertical | 3 | 100 x 5 |
| 2500 | with long surface vertical | 4 | 100 x 5 |
| 3150 (3200) *(NOTE) | with long surface vertical | 3 | 100 x 10 |
| AE4000-SSA D/O | with long surface vertical | 3 | 150 x 10 |
| AE4000-SSA FIX | with long surface vertical | 4 | 150 x 10 |
| AE4000-SSC 3P D/O | with long surface vertical | (L1 and L3) 4 | 150 x 10 |
| | | (L2) 3 | 150 x 10 |
| AE4000-SSC 3P FIX | with long surface vertical | 3 | 150 x 10 |
| 4000 | with long surface vertical | 4 | 100 x 10 |
| 5000 | with long surface vertical | 4 | 150 x 10 |
| 6300 | with long surface vertical | 4 | 200 x 10 |

Tab. 2-7: Conductor size (IEC947-1; 40 °C ambient temperature; open air)

NOTE

The temperature rise at a rated current of 3200 A corresponds to the requirement of IEC 947-1 at a connecting conductor size for a rated current of 3150 A.

In case of more than 3200 A, there are no conductor sizes prescribed in IEC 947-1.

2.8 Wiring diagram

2.8.1 Diagram due to terminal designation

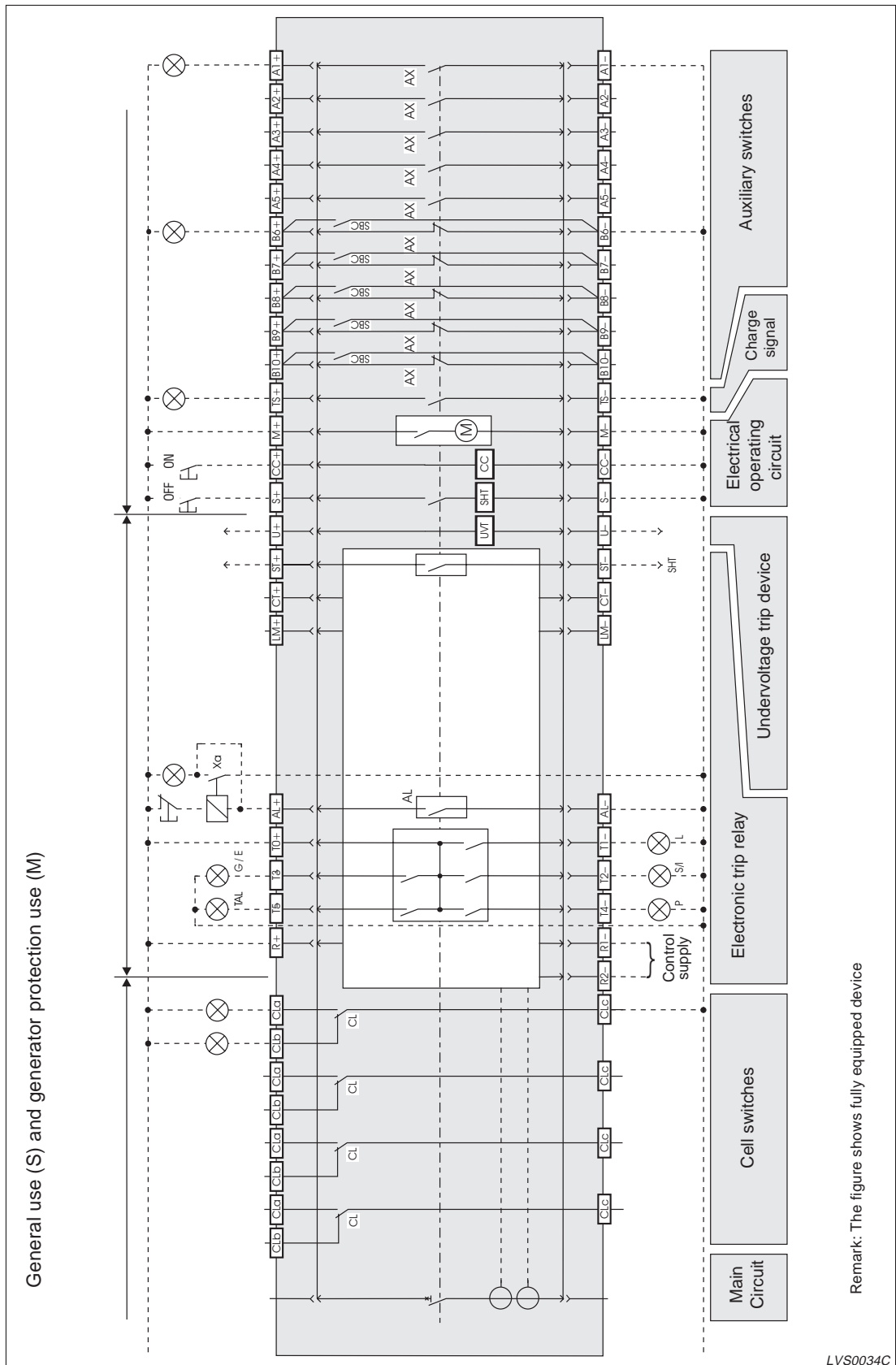

Fig. 2-31: Wiring diagram due to terminal designation

NOTES

On the drawout type, the cables are cut to length, long enough to allow the control circuit terminal block to be moved to the left or right by 5 mm.

When a coil load is connected in the same control circuit of the OCR, surge absorbers are required to absorb the surge voltage.

Mark description (terminals)

| | | | |
|----------|--|-------------|--|
| A1 - A5 | Auxiliary switch contact a | CT | For neutral pole CT or external ZCT connection |
| B6 - B10 | Auxiliary switch contact b | LM | Load ammeter |
| TS | Charge signal | AL | OCR alarm contact |
| M | Motor charging | T0 - T3 | Trip indication contact |
| CC | Closing coil | T4 | Pre-alarm indication contact |
| S | Shunt trip | T5 | Unusual temperature contact |
| U | Under voltage trip | R1- R2- | Electronic trip relay unit control supply |
| ST | Earth leakage trip output (for SHT trip) | CLa CLb CLc | Cell switch |

Tab. 2-8: Mark descriptions (terminals)

NOTE

If the optional functions PAL, ER, TI, LM and TAL are attached, a control source is required.



CAUTION:

The control supply source should be free from distortion to prevent the breaker from malfunction.

Mark description (accessories)

| | | | |
|---------|--------------------------------------|------------|--|
| (M) | Motor | (X) G or E | Ground fault trip or earth leakage indicator LED |
| CC | Closing coil | (X) P | Pre-alarm indication LED |
| SHT | Shunt trip device | (X) TAL | Unusual temperature indication LED |
| UVT | Undervoltage trip device | | Self-hold relay |
| AL | OCR alarm | — | Wiring completed by the factory |
| (X) L | LTD trip indication LED | --- | Wiring to be done by the user |
| (X) S/I | STD trip or INST trip indication LED | | |

Tab. 2-9: Mark description (accessories)

| | | |
|---------|-----------------|--------|
| Voltage | 100–120 V AC | R+ R1- |
| | 200–240 V AC | R+ R2- |
| | 24 ... 125 V DC | R+ R1- |

Tab. 2-10:

Control supply terminals

2.8.2 Diagram according to EN50005

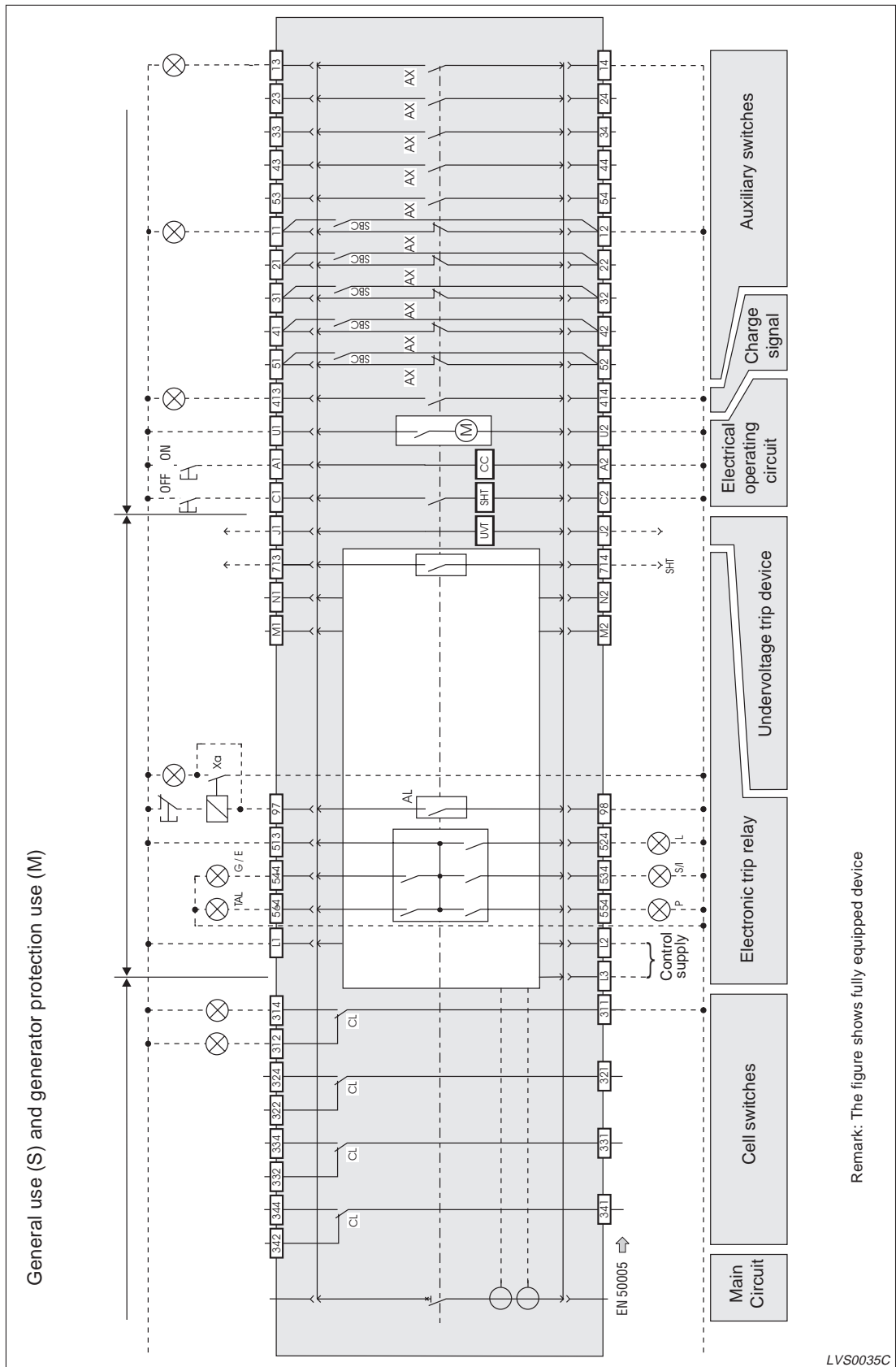

Fig. 2-32: Wiring diagram due to terminal designation

NOTES

On the drawout type, the cables are cut to length, long enough to allow the control circuit terminal block to be moved to the left or right by 5 mm.

When a coil load is connected in the same control circuit of the OCR, surge absorbers are required to absorb the surge voltage.

Mark description (terminals)

| | | | |
|---------|--|-----------|--|
| 13 - 54 | Auxiliary switch contact a | N1 N2 | For neutral pole CT or external ZCT connection |
| 11 - 52 | Auxiliary switch contact b | M1 M2 | Load ammeter |
| 413 414 | Charge signal | 97 98 | OCR alarm contact |
| U1 U2 | Motor charging | 524 - 544 | Trip indication contact |
| A1 A2 | Closing coil | 554 | Pre-alarm indication contact |
| C1 C2 | Shunt trip | 564 | Unusual temperature contact |
| J1 J2 | Under voltage trip | L1 L2 L3 | Electronic trip relay unit control supply |
| 713 714 | Earth leakage trip output (for SHT trip) | 311 - 344 | Cell switch |

Tab. 2-11: Mark descriptions (terminals)

NOTE

If the optional functions PAL, ER, TI, LM and TAL are attached, a control source is required.

**CAUTION:**

The control supply source should be free from distortion to prevent the breaker from malfunction.

Mark description (accessories)

| | | | |
|---------|--------------------------------------|------------|--|
| (M) | Motor | (X) G or E | Ground fault trip or earth leakage indicator LED |
| CC | Closing coil | (X) P | Pre-alarm indication LED |
| SHT | Shunt trip device | (X) TAL | Unusual temperature indication LED |
| UVT | Undervoltage trip device | | Self-hold relay |
| AL | OCR alarm | — | Wiring completed by the factory |
| (X) L | LTD trip indication LED | --- | Wiring to be done by the user |
| (X) S/I | STD trip or INST trip indication LED | | |

Tab. 2-12: Mark description (accessories)

| | | |
|---------|-----------------|-------|
| Voltage | 100–120 V AC | L1 L2 |
| | 200–240 V AC | L1 L3 |
| | 24 ... 125 V DC | L1 L2 |

Tab. 2-13:

Control supply terminals

2.9 Charging operation

2.9.1 Manual charging

In order to charge the closing spring, operate the charging handle with 7 or 8 full strokes.

When the closing spring is charged completely, the charging indicator shows the message “CHARGED”.

NOTE

In case of AE4000–AE6300-SS, about 1.5 times larger force is required to operate charging handle compared with the operating force AE-SS/SH (1000–3200), because of the difference of closing spring.

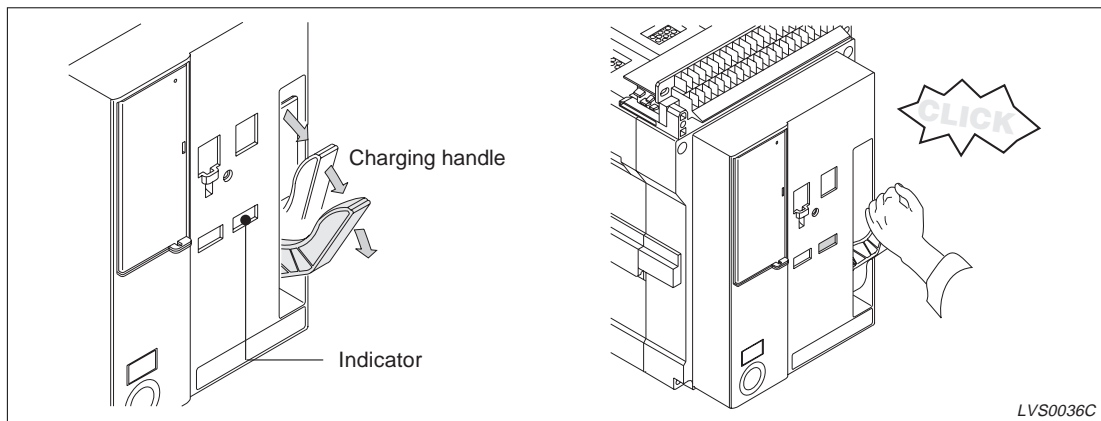

Fig. 2-33: Manual charging

2.9.2 Motor charging

NOTE

Motor charging is only available if your breaker is equipped with a motor charging device. For further Information refer to par. 4.5.

In this mode the closing spring is electrically charged. This is an ON charge function in which the spring is automatically charged when the breaker is closed. The closing coil (CC) is required to remotely close the breaker and the shunt trip device (SHT) is required to remotely open the breaker.

| Rated voltage (V) | Applicable voltage range (V) | Operating voltage (V) | Inrush current (peak value) (A) | Continuous current (A) | Charging time |
|-------------------|------------------------------|-----------------------|---------------------------------|------------------------|----------------|
| DC 24 V | 18 – 26.4 | 24 | 22 | 6 | 5 sec. or less |
| DC 48 V | 35 – 52.8 | 48 | 14 | 3 | 5 sec. or less |
| AC/DC 100–125 V | 85 – 137.5 | 100 | 10 | 3 | 5 sec. or less |
| | | 125 | 12 | 3 | 5 sec. or less |
| AC/DC 200–250 V | 170 – 275 | 200 | 5 | 1 | 5 sec. or less |
| | | 250 | 6 | 1 | 5 sec. or less |

Tab. 2-14: Motor charging rating for AE1000–AE3200-SS/SH/SSC/AE4000-SSA 3P

| Rated voltage (V) | Applicable voltage range (V) | Operating voltage (V) | Inrush current (peak value) (A) | Continuous current (A) | Charging time |
|---------------------|------------------------------|-----------------------|---------------------------------|------------------------|----------------|
| AC/DC 100–125 V | 85 – 137.5 | 100 | 10 | 4 | 5 sec. or less |
| | | 125 | 12 | 4 | 5 sec. or less |
| AC/DC 200–2250 V | 170 – 275 | 200 | 7 | 2 | 5 sec. or less |
| | | 250 | 8 | 2 | 5 sec. or less |

Tab. 2-15: Motorantriebsdaten für AE4000–AE6300-SS/AE4000-SSA 4P

NOTES

- | Manual charging operation is also possible with the charging handle.
- | Pumping prevention is assured both electrically and mechanically.
- | As long as the OFF button is pressed, a closing operation is impossible.
- | When the OFF lock device is used, perform the closing operation after the lock has been released.
- | Although the charging motor has a short time rating it can be continuously operated for up to ten times.
- | The opening and closing of the drawout type breaker must be carried out in either the connected or the test position.
- | If an under voltage trip device is fitted, its rated voltage should be applied before attempting to close the breaker.
- | Since the charge complete contact is separate from the motor charging unit, the sequence can be arranged as required.



Abb: 2-34

Wiring diagram for motor device

LVS0037C

2.10 Opening / closing operation

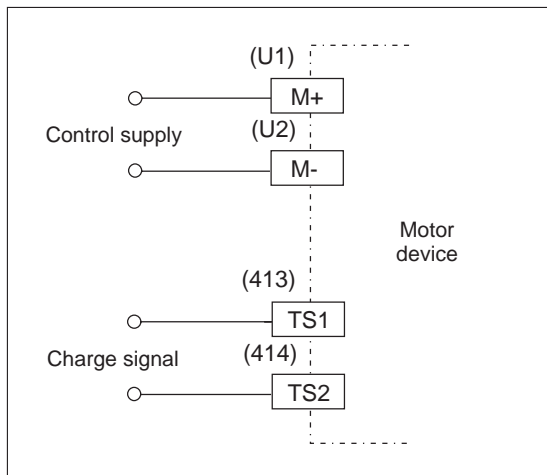
2.10.1 Manual operation

Closing

Push the ON button to close the breaker. The ON/OFF indicator will show “ON”, and the charging indicator will show “DISCHARGED”.

NOTES

If an under voltage trip device is provided, its rated voltage should be applied before attempting to close and open the breaker.

Also release the OFF lock device (padlock, cylinder lock, castell lock, etc.).

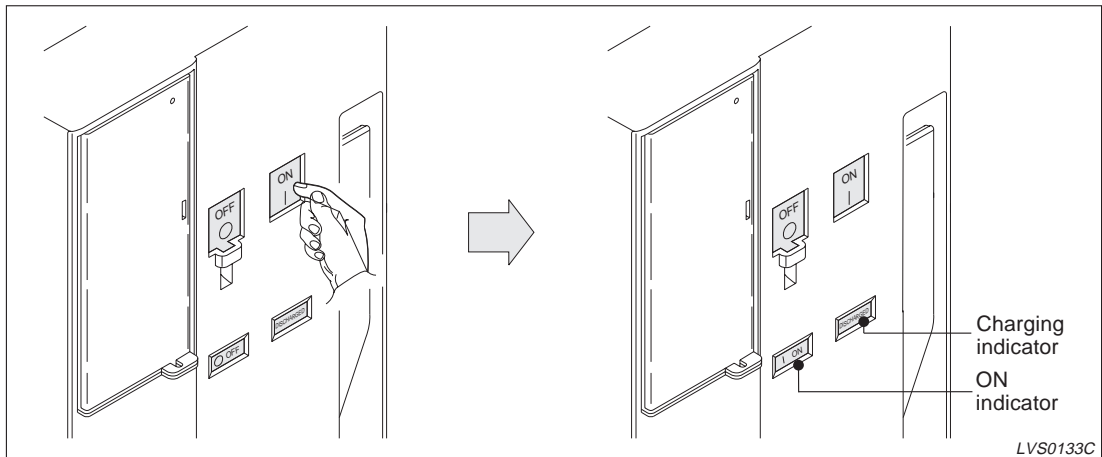

Fig. 2-35: Closing operation

Opening

Push the OFF button to open the breaker, and the ON/OFF indicator will show “OFF”.

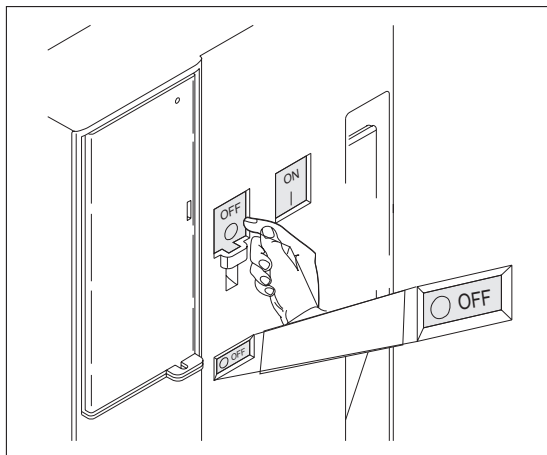

Fig. 2-36: Opening operation

LVS0039C

2.10.2 Electrical operation

Closing

Remote closing can be made by energizing the closing coil. Apply the rated voltage (signal time 30 ms min.) to the control terminals CC+ (A1) and CC- (A2), to close the breaker.

The unit comprises an anti-pumping circuit which allows only one action without first de-energizing, then re-energizing.

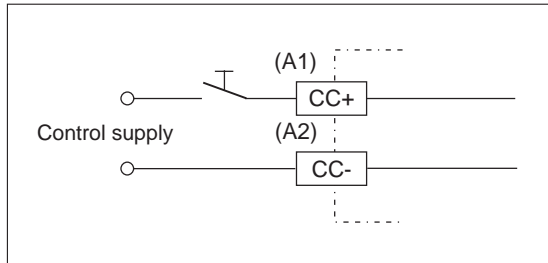

Fig. 2-37:
CC circuit diagram

LVS0040C

Opening

Remote opening can be made by energizing the SHT trip device or de-energizing the UVT trip device. As for the SHT, apply the rated voltage to the terminal S+ (C1) and S- (C2). In case of UVT remote opening is also possible by opening the circuit across the terminals US+ (DT1) and US- (DT2) of the UVT controller.

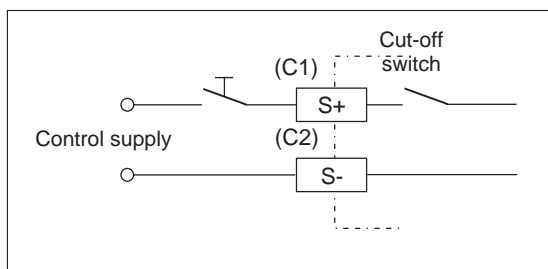

Fig. 2-38:
SHT circuit diagram

LVS0041C

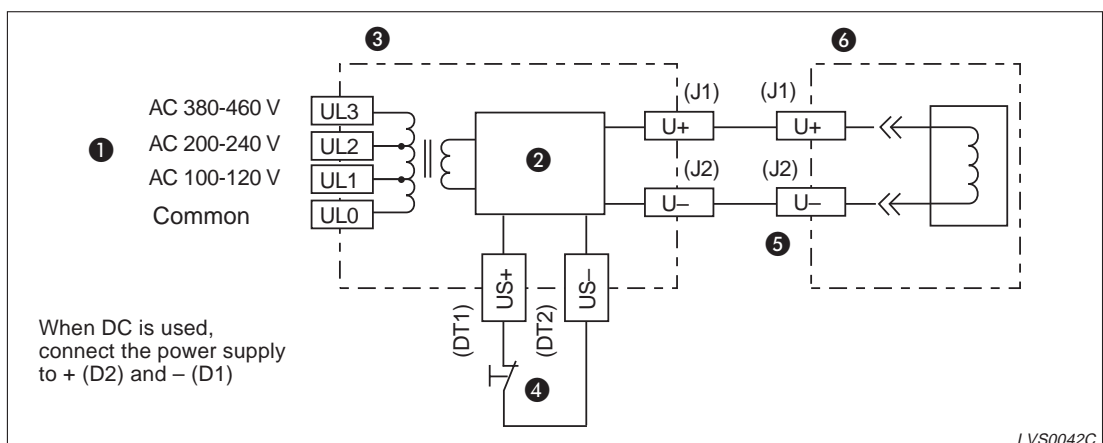

Fig. 2-39: UVT circuit diagram

LVS0042C

- ① Power supply
- ② Control circuit
- ③ UVT controller
- ④ Emergency trip button
- ⑤ Control circuit connector
- ⑥ Air circuit breaker

2.11 Operation of the drawout mechanism

2.11.1 Drawout operation

- ① Release the fixing bolts (AE4000–AE6300) as mentioned in fig. 2-16.
- ② Press the OFF button and insert the handle into the drawout handle aperture.

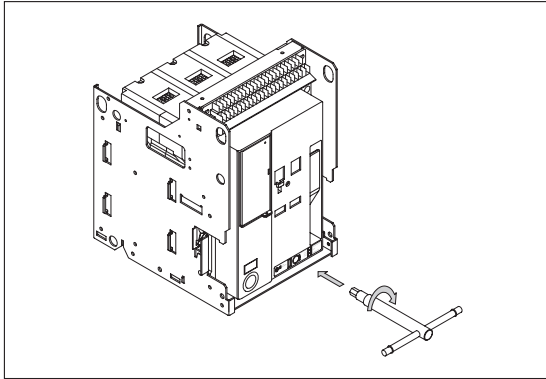

Fig. 2-40:
Drawout of the breaker (1)

LVS0038C

- ③ Slowly turn the drawout handle in clockwise direction until the breaker is drawn out a little.
- ④ Release the extension rail lock levers, and pull the extension rails forward until the rails come to a stop.

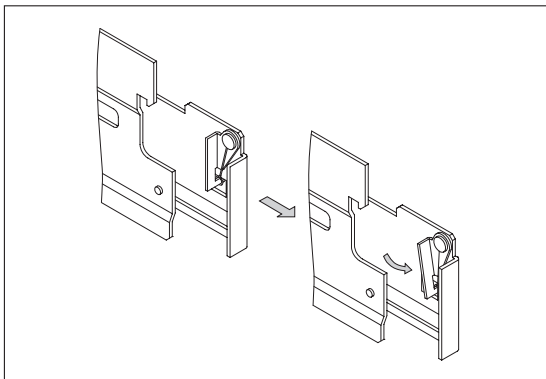
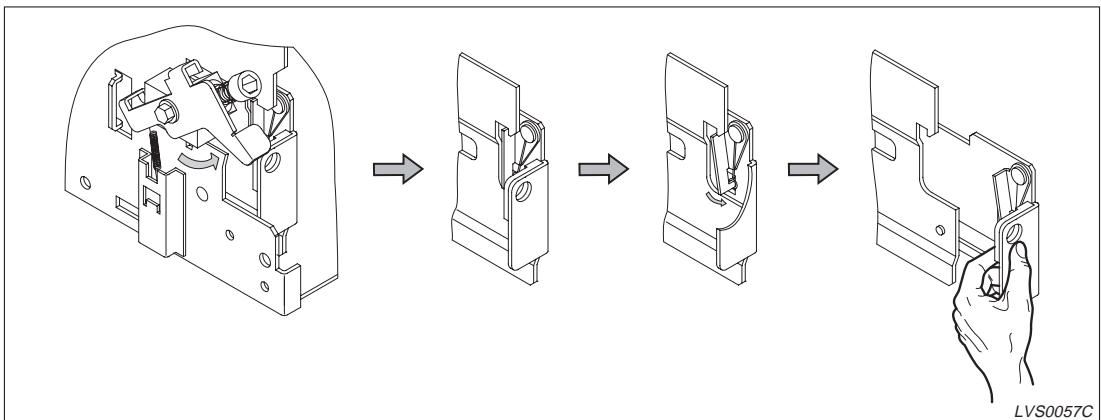

Fig. 2-41:
Drawout of the breaker (2)

LVS0055C

For the AE-SH series and AE4000–AE6300 please draw out the rail like described below.



LVS0057C

Fig. 2-42: Drawout of the breaker (3)

NOTE

| For further details please refer to paragraph 2.6.2.

2.11.2 Insert operation

- ① Release the extension rail lock levers, and pull the extension rails forward.

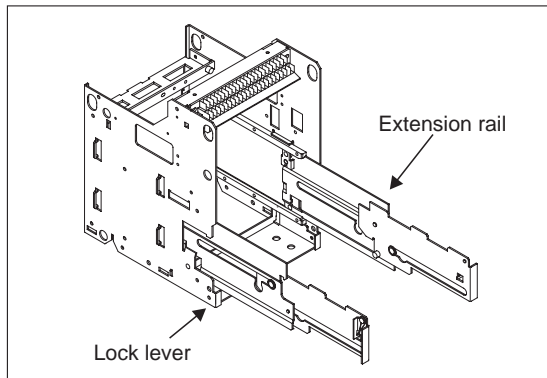

Fig. 2-45:
Insertion of the breaker (1)

LVS0049C

- ② Place the breaker on the rail as shown in fig. 2-43. Put the concave part of the breaker into the projection of the rail.

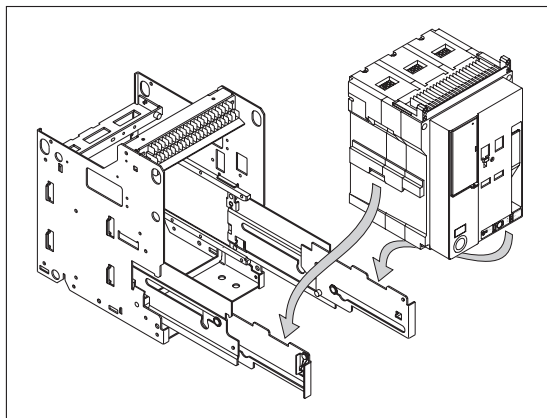

Fig. 2-43:
Insertion of the breaker (2)

LVS0186C

NOTE

When the breaker AE4000–AE6300-SS is set on the rails, put the concave of the breaker into the projection of the rails. Otherwise the concave of the breaker crack because of its large weight.

- ③ Slowly push the breaker in until it cannot be moved anymore.

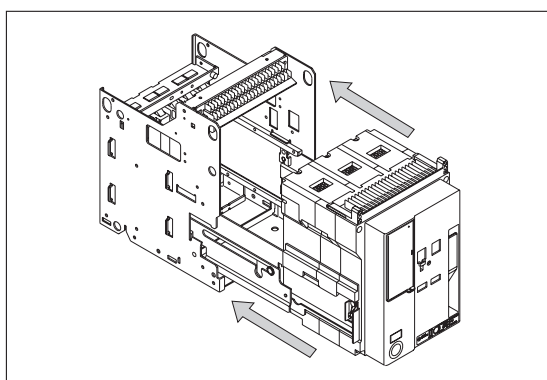

Fig. 2-44:
Insertion of the breaker (3)

LVS0185C

- ④ Keeping the OFF button pushed, insert the handle into the drawout handle aperture.

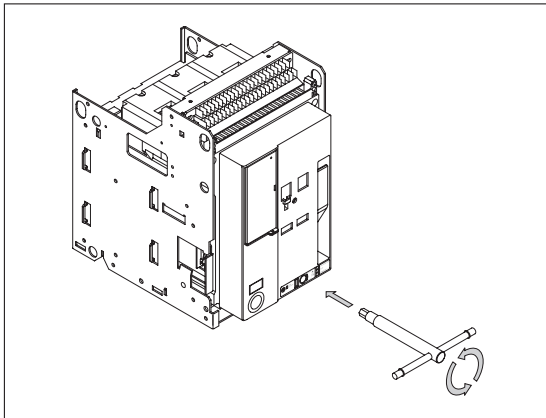

Fig. 2-46:
Insertion of the breaker (4)

LVS0059C

NOTE

The drawout handle cannot be inserted unless the OFF button is being pushed.

- ⑤ When the lock plate is projecting, push the lock plate in fully until it is latched, hold the lockplate and turn the drawout handle clockwise in order to insert the breaker.

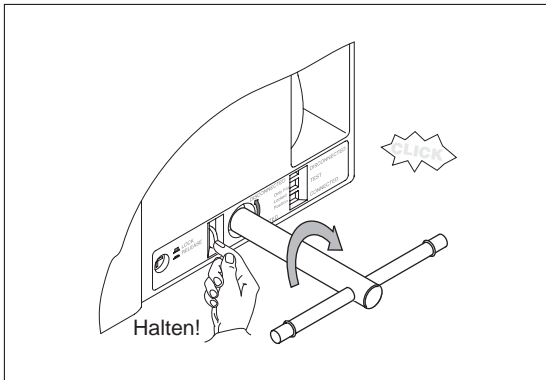

Fig. 2-47:
Insertion of the breaker (5)

LVS0046C

- ⑥ When the breaker reaches the TEST position, the lock plate automatically projects and the drawout handle is locked.

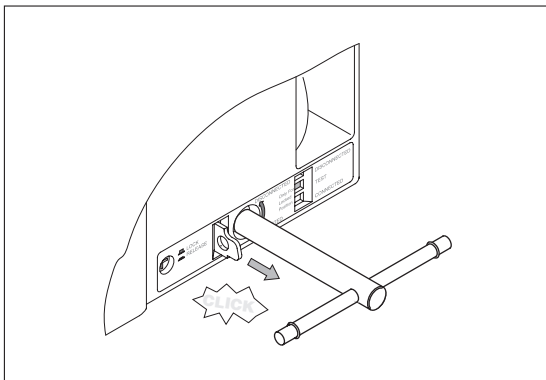

Fig. 2-48:
Insertion of the breaker (6)

LVS0047C

NOTE

Do not turn the drawout handle any more when the drawout handle is locked. Otherwise you might cause a serious problem.

- ⑦ Push the lock plate in fully until it is latched and turn the drawout handle clockwise again until the lock plate projects. The inserting operation is then finished. At this point, the drawout position indicator will show the CONNECTED position.

For the AE-SH series and AE4000–AE6300 (see fig. 2-49), be sure to tighten the set screws on both sides to secure the breaker.

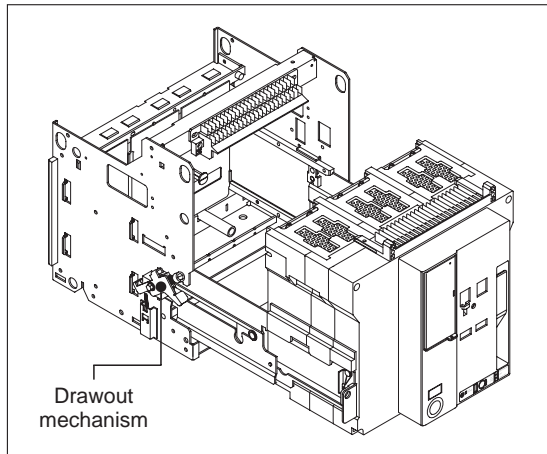

Fig. 2-49:
Drawout mechanism at AE-SH series and AE4000–AE6300

LVS0044C

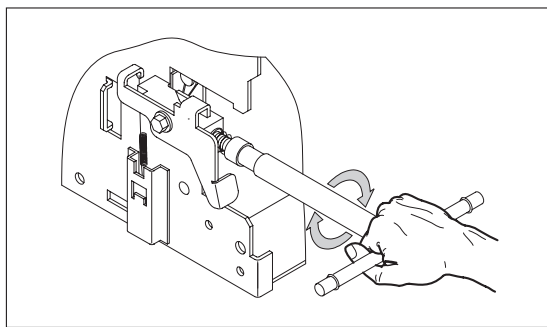

Fig. 2-50:
Insertion of the breaker (AE-SH series and AE4000–AE6300) and securing the drawout mechanism

LVS0043C

NOTES

Do not turn the handle any further as soon as the insertion is completed.

The positions “CONNECTED” and “TEST” of the air circuit breaker are judged from the lock plate which is only in the projecting.

When you find it hard to release the lock plate, slightly turn the drawout handle clockwise.

Closing the breaker is impossible when inserting the drawout handle.

When the inserting operation is finished you can secure the lockplate with a lock, so that nobody can remove the breaker.

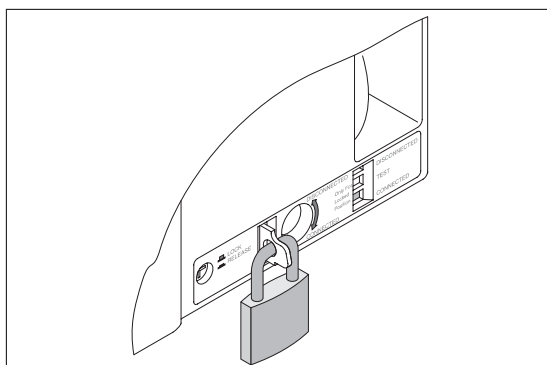

Fig. 2-51:
Locking the draw-in position

LVS0048C

3 Operation

3.1 Setting the operating characteristics

When using the digital relay, please refer to the corresponding manual.

3.1.1 Setting procedure

- ① Prepare a small flat-tipped screwdriver.
- ② Insert the flat-tipped screwdriver into the opening of the electronic trip relay cover. Then, lightly turn the screwdriver to the left as shown in fig. 3-1, and the relay cover will come open.

NOTE

Turn the screwdriver in the direction of the arrow mark in order to open the relay cover (fig. 3-1 and fig. 3-2).

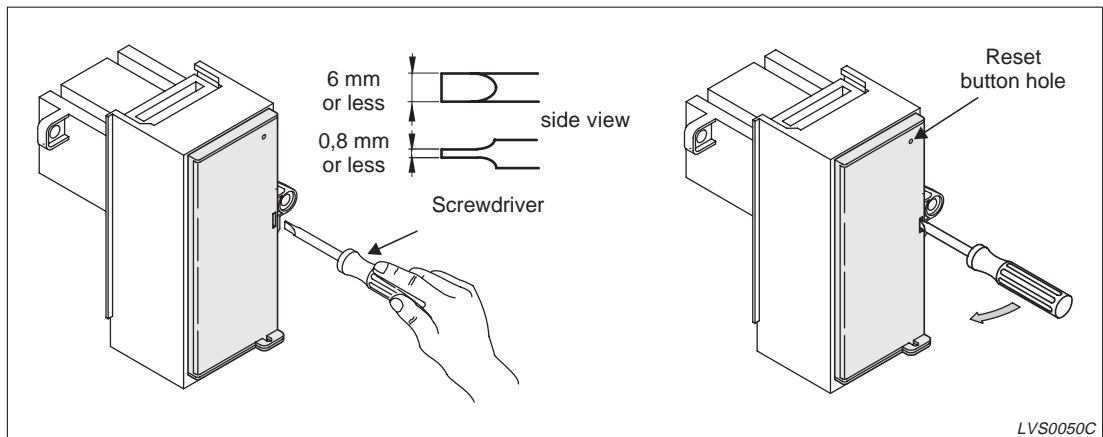

Fig. 3-1: How to open the relay cover (1)

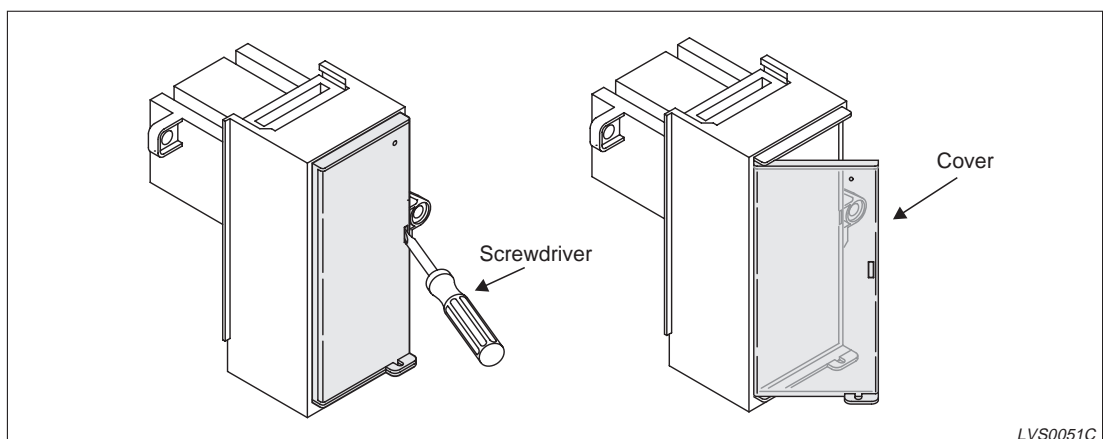

Fig. 3-2: How to open the relay cover (2)

③ There are 3 switches for setting the required tripping characteristics and they should be used as follows.

● Step type

A rotary switch is used. Do not stop the switch at the middle position of the scale. The same setting value is achieved, when the scale is positioned at the thick line. (Set the switch with a torque of 0.1 Nm or less.)

● Slide switch type

Slide the switch to the left or right. (Set the switch with a torque of 0.1 Nm or less.)

● Push-button type

A push-button is provided for temporary operation. Push it with a force of 1 kg or less. Before operating, make sure that the push-button is in the projecting state.

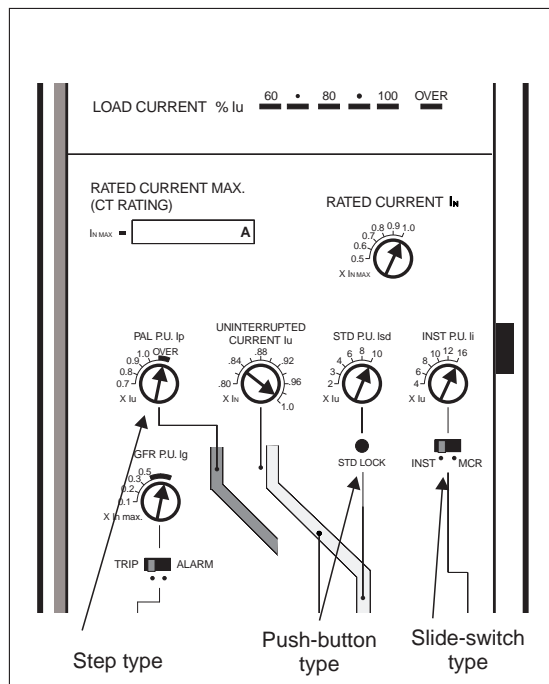

Fig. 3-3:
Switches for setting

LVS0054C

④ Keep in mind that the current value which is used as the reference of the load current indication LED varies depending on the characteristic setting (table 3-1).

⑤ When the characteristic is set, use a device like a field tester etc. to make sure that the required characteristic has been set.

If the “OVER” LED of the S type or the “100 %” LED of the M type is lit, the breaker will trip after a specified time.

| Application | Type | Basic current | Nameplate indication |
|--------------------------|------|-----------------------------|---|
| General use | S | I_u uninterrupted current | Load current % I_u 60 ◦ 80 ◦ 100 OVER |
| Generator protection use | M | I_L LTD pick-up current | Load current % I_L 50 ◦ 70 ◦ 90 100 |

Tab. 3-1: Current values

3.1.2 Sealing

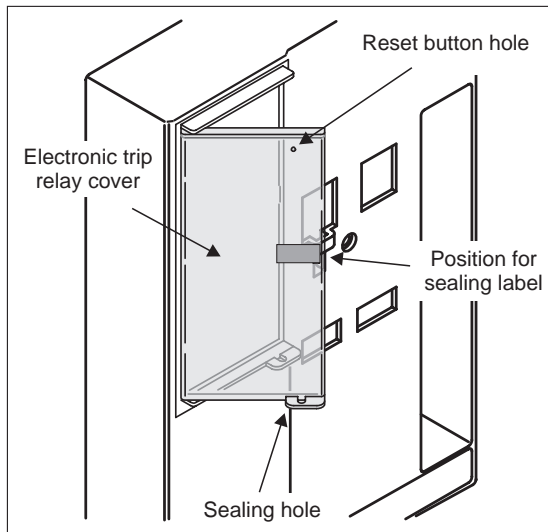

Fig. 3-4:
Sealing

LVS0053C

Two sealing labels are provided for use as follows. Select the required sealing label.

- ① Stick the sealing label on the opening of the electronic trip relay cover, and close the cover. The cover cannot be opened unless the sealing label is removed.

NOTE

| The sealing label is co-packed.

- ② Seal the electronic trip relay cover by using the sealing hole at the bottom of the relay cover.

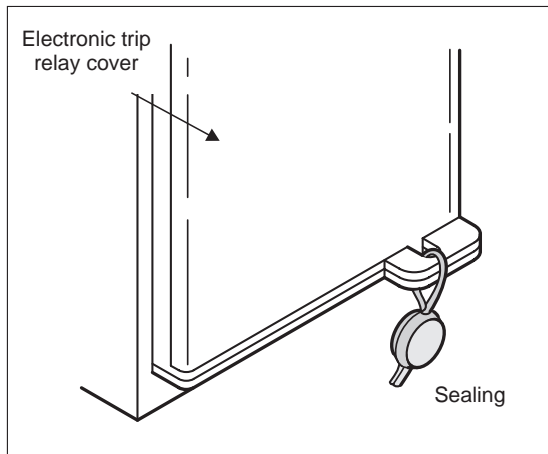

Fig. 3-5:
Sealing against opening

LVS0052C

3.1.3 Resetting the indicator

To reset the trip indicator (L = long time delay, S/I = short time delay/instantaneous) the pre-alarm indicator (PAL-OUT) etc, remove the cause and push the reset button on the front panel of the electronic trip relay, or turn off the control power supply for 1 second or more.

3.1.4 Characteristics setting for the S type

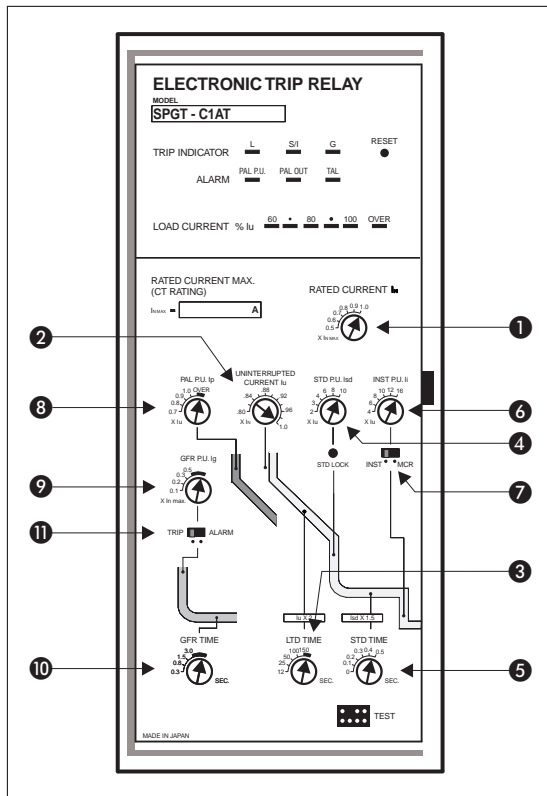

Fig. 3-6:
Characteristics setting for the S type

LVS0060C

| No. | Setting item | Mark | Adjustable setting range | | |
|-----|----------------------------------|-----------------|---|--|--|
| | | | AE1000-4000 | AE5000 | AE6300 |
| ① | Rated current | I_N | 0.5 - 0.6 - 0.7 - 0.8 - 0.9 - 1 x I_N MAX (0.8 - 0.9 - 1.0: AE4000-SSA/SSC) | | |
| ② | Uninterrupted current | CURR I_U | 0.80 - 0.82 - 0.84 - 0.86 - 0.88 - 0.90 - 0.92 - 0.94 - 0.96 - 0.98 - 1.0 x I_N | | |
| ③ | Long time delay time | LTD Time | 12 - 25 - 50 - 100 - 150 s at 2 x I_U (± 20 %) | | |
| ④ | Short time delay pick-up current | STD P.U. I_S | 2 - 3 - 4 - 6 - 8 - 10 x I_N (± 15 %) | | |
| ⑤ | Short time delay time | STD Time | 0 - 0.1 - 0.2 - 0.3 - 0.4 - 0.5 s at 1.5 x I_S (± 20 %) | | |
| ⑥ | Instantaneous pick-up current | INST P.U. I_I | 4 - 6 - 8 - 10 - 12 - 16 x I_N (± 15 %) | 4 - 6 - 8 - 10 - 12 x I_N (± 15 %) | 4 - 6 - 8 - 10 x I_N (± 15 %) |
| ⑦ | Instantaneous/MCR switch | INST MCR | The MCR type is selected when it is set to the right. | | |
| ⑧ | Pre-alarm pick-up current | PAL P.U. I_P | 0.7 - 0.8 - 0.9 - 1.0 - OVER x I_U (± 10 %) | | |
| ⑨ | Ground fault pick-up current | GFR P.U. I_G | 0.1 - 0.2 - 0.3 - 0.5 x I_N MAX (± 20 %) | 0.2 - 0.3 - 0.5 x I_N MAX (± 20 %) (AE4000-SSC) | |
| ⑩ | Ground fault operating time | GFR Time | 0.3 - 0.8 - 1.5 - 3 s at 1.5 x I_G | | |
| ⑪ | Ground fault alarm switch | GFR TRIP/ALARM | The ground fault pick-up alarm only works when it is set to the right. | | |

Tab. 3-2: Characteristics setting for the S type

The **bold** marked values show the setting at time of shipment.



CAUTION

For breakers type AE4000-6300-SS, do not set the instantaneous pick up to larger current than the rated interrupting capacity.

e mailfor S type

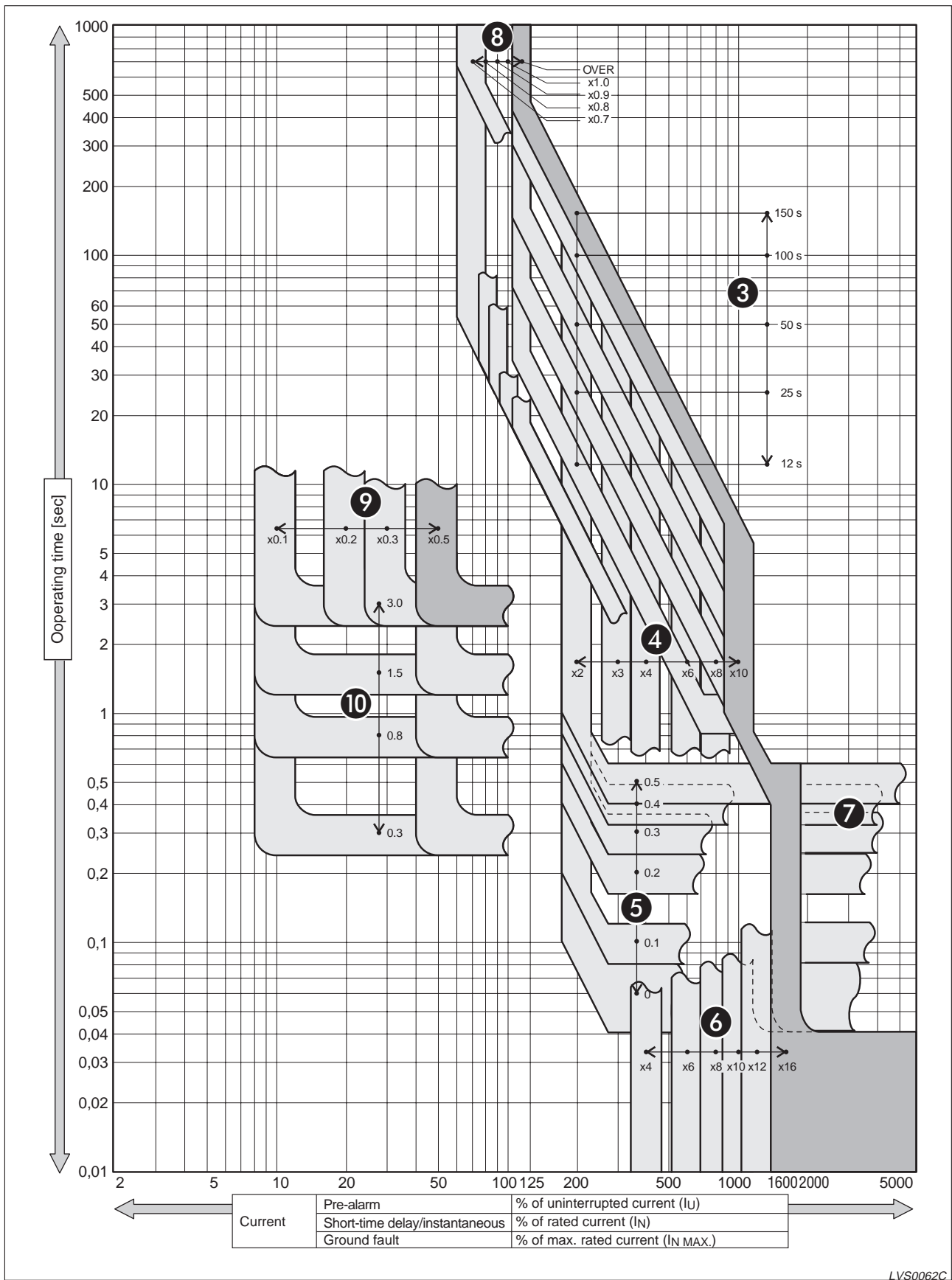

Fig. 3-7: Characteristics setting for the S types AE1000-SS/SH-AE32000-SS/SH, AE4000-SSA/SSC, AE4000-SS-AE6300-SS

The numbers of the figure above correspond to the numbers in Fig. 3-6 and Tab. 3-2.

3.1.5 Characteristics setting for the M type

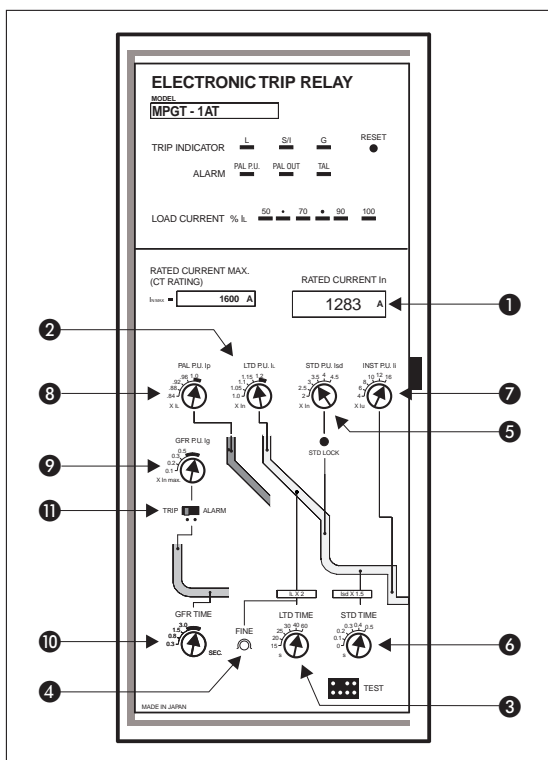

Fig. 3-8:
Characteristics setting for the M type

LVS0063C

| No. | Setting item | Mark | Adjustable setting range | | |
|-----|----------------------------------|-----------------|---|---|--|
| | | | AE1000-AE4000 | AE5000 | AE6300 |
| ① | Rated current | I_N | 0.5 - 1.0 x $I_{N\ MAX}$ (will be set in factory when shipping) | | |
| ② | Uninterrupted current | LTD P.U. I_L | 1 - 1.05 - 1.1 - 1.15 - 1.2 x I_N ($\pm 5\%$) | | |
| ③ | Long time delay time | LTD TIME | 15 - 20 - 25 - 30 - 40 - 60 s at 1.2 x I_L ($\pm 20\%$) | | |
| ④ | Short time delay pick-up current | FINE | 0.8 - 1.0 - 1.2 x T_L | | |
| ⑤ | Short time delay time | STD P.U. I_S | 2 - 2.5 - 3 - 3.5 - 4 - 4.5 x I_N ($\pm 15\%$) | | |
| ⑥ | Instantaneous pick-up current | STD TIME | 0 - 0.1 - 0.2 - 0.3 - 0.4 - 0.5 s at 1.5 x I_S ($\pm 20\%$) | | |
| ⑦ | Instantaneous/MCR switch | INST P.U. I_I | 4 - 6 - 8 - 10 - 12 - 16 x I_N ($\pm 15\%$) | 4 - 6 - 8 - 10 - 12 x I_N ($\pm 15\%$) | 4 - 6 - 8 - 10 x I_N ($\pm 15\%$) |
| ⑧ | Pre-alarm pick-up current | PAL P.U. I_P | 0.84 - 0.88 - 0.92 - 0.96 - 1.0 x I_L ($\pm 5\%$) | | |
| ⑨ | Ground fault pick-up current | GFR P.U. I_G | 0.1 - 0.2 - 0.3 - 0.5 x $I_{N\ MAX}$ ($\pm 20\%$) | 0.2 - 0.3 - 0.5 x $I_{N\ MAX}$ ($\pm 20\%$) (AE4000-SSC) | |
| ⑩ | Ground fault operating time | GFR TIME | 0.3 - 0.8 - 1.5 - 3 s at 1.5 x I_G ($\pm 20\%$) | | |
| ⑪ | Ground fault alarm switch | GFR TRIP/ALARM | The ground fault pick-up alarm only works when it is set to the right position. | | |

Tab. 3-3: Characteristics setting for the M type

The **bold** marked values show the setting at time of shipment.

Characteristics for M type

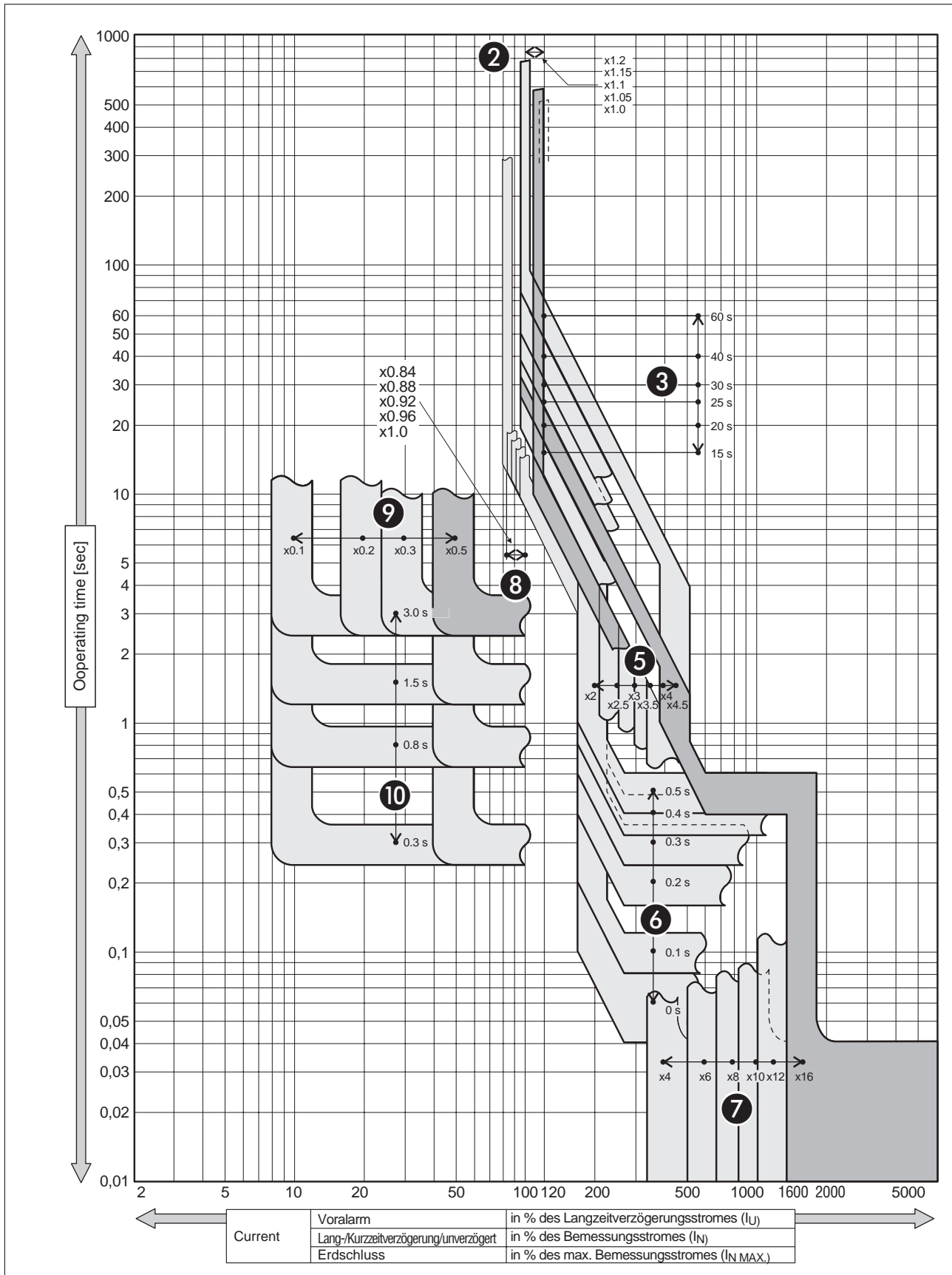

Fig. 3-9: Auslösekennlinie für die M-Typen AE1000-SS/SH–AE32000-SS/SH, AS4000-SSA/SSC, AE4000-SS–AE6300-SS

The numbers of the figure above correspond to the numbers in Fig. 3-8 and Tab. 3-3.

3.1.6 Characteristics setting for the B type

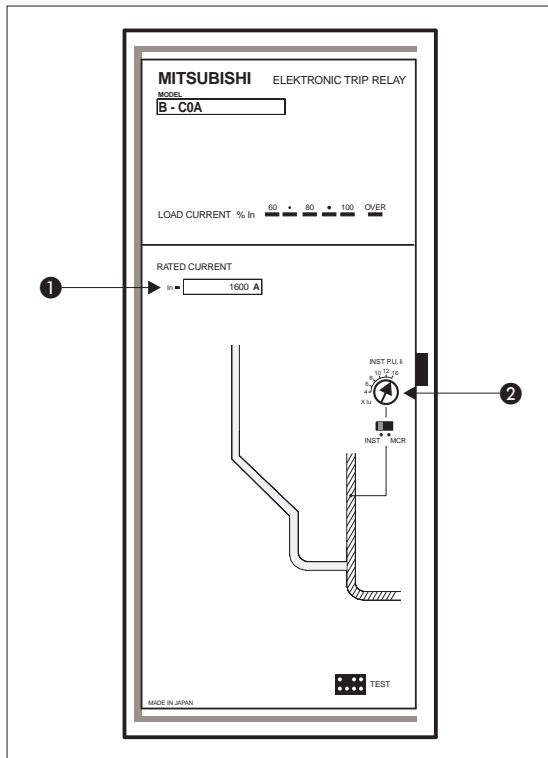

Fig. 3-10:
Characteristics setting for the B type

LVS1063C

| No. | Setting item | Mark | Adjustable setting range | | |
|-----|-------------------------------|--------------------------|--|---|--|
| | | | AE1000-AE4000 | AE5000-SS | AE6300-SS |
| ① | Rated current | I _N | 0.5 - 0.6 - 0.7 - 0.8 - 0.9 - 1.0 x I _n max (will be set in factory when shipping) | | |
| ② | Instantaneous pick-up current | INST P.U. I _i | 4 - 6 - 8 - 10 - 12 - 16 x I _n (±15 %) | 4 - 6 - 8 - 10 - 12 x I _n (±15 %) | 4 - 6 - 8 - 10 x I _n (±15 %) |

Tab. 3-4: Characteristics setting for the B type

Characteristics for the B type

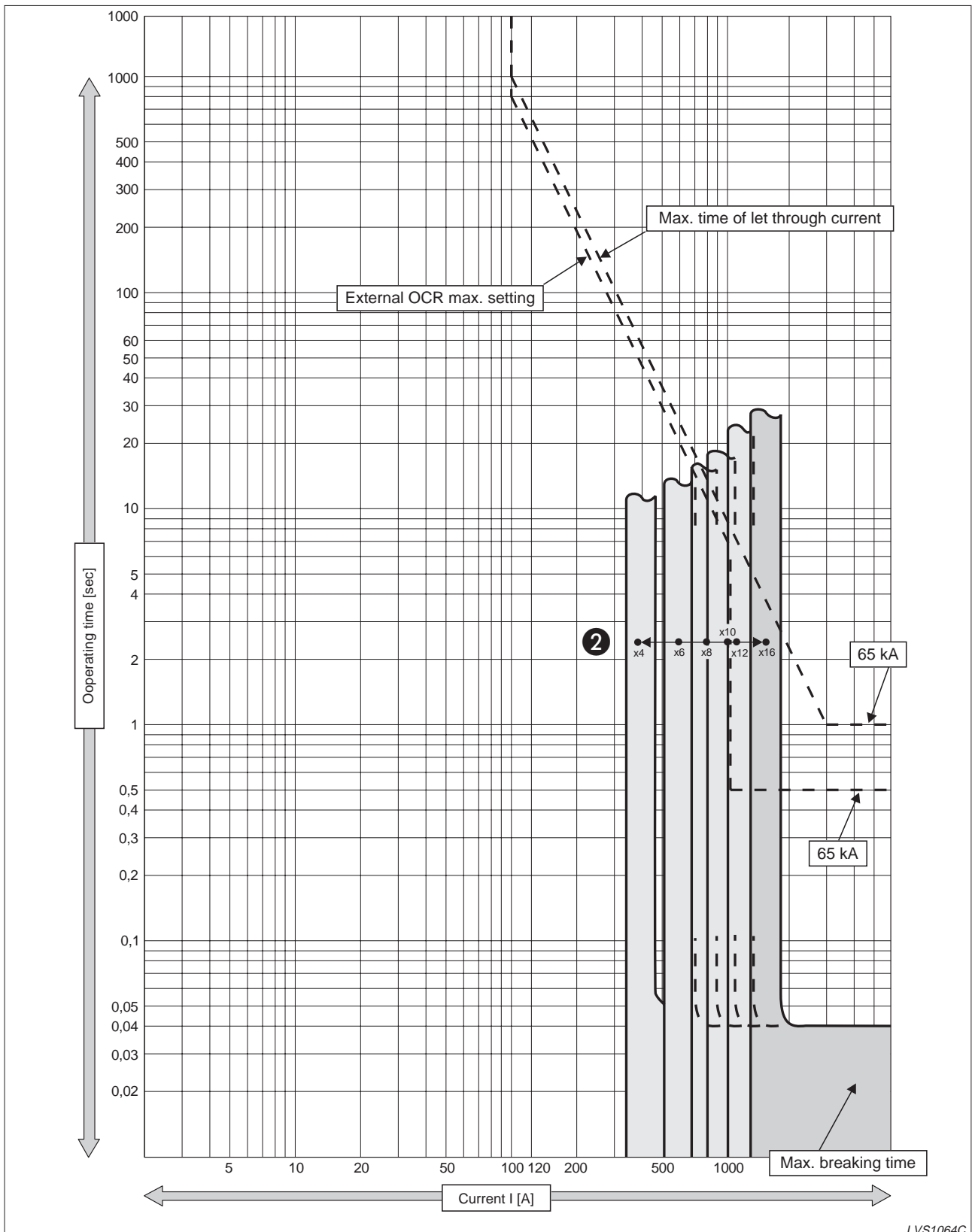

Fig. 3-11: Characteristics setting for the B types AE1000-SS/SH-AE32000-SS/SH, AE4000-SS-AE6300-SS

The numbers of the figure above correspond to the numbers in Fig. 3-10 and Tab. 3-4.

3.1.7 Setting example for S Type – General use

The following example shows in a simple way how you can set your required values on the S type trip relay.

Additional all current settings and operation times are calculated and shown.

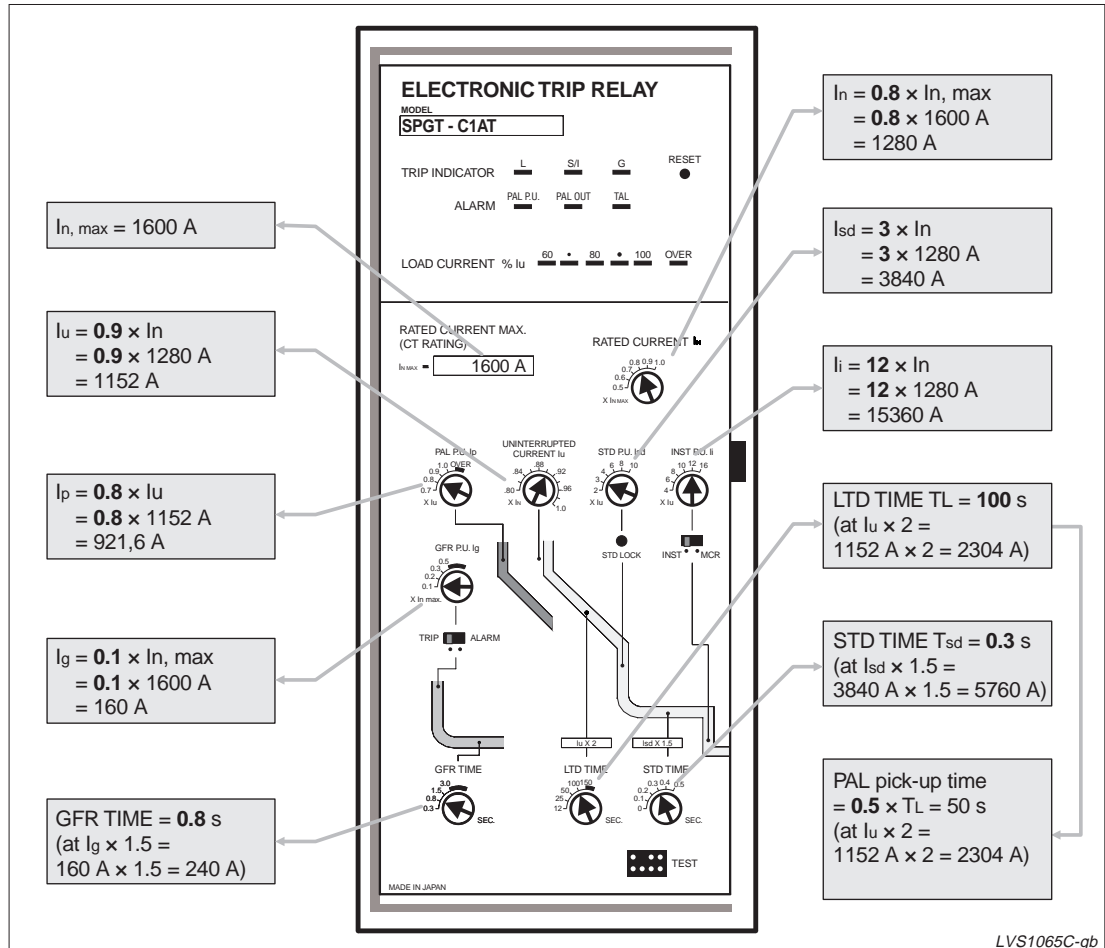

Fig. 3-12: Setting example for S type

Actual settings are as in the following table:

| Mark | Function | Setting value |
|--------------|-------------------------------|------------------------------|
| $I_{n, max}$ | Max. rated current | 1600 A |
| I_n | Set rated value | 1280 A |
| I_u | Uninterrupted current | 1152 A |
| LTD TIME | Long-time delay time | 100 s \pm 20 % (at 2304 A) |
| I_{sd} | Short-time delay P.U. current | 3840 A \pm 15 % |
| STD TIME | Short-time delay time | 0.3 s \pm 20% (at 5760 A) |
| I_i | Instantaneous P.U. current | 15,360 A \pm 15% |
| I_p | Pre-alarm current | 921.6 A \pm 10% |
| PAL time | Pre-alarm pick-up time | 50 s \pm 20% (at 2304 A) |
| I_g | Ground fault P.U. current | 160 A \pm 20% |
| GFR TIME | Ground fault time | 0.8 s \pm 20% (at 240 A) |

Tab. 3-5: Description of functions and setting values

Characteristics for the setting example:

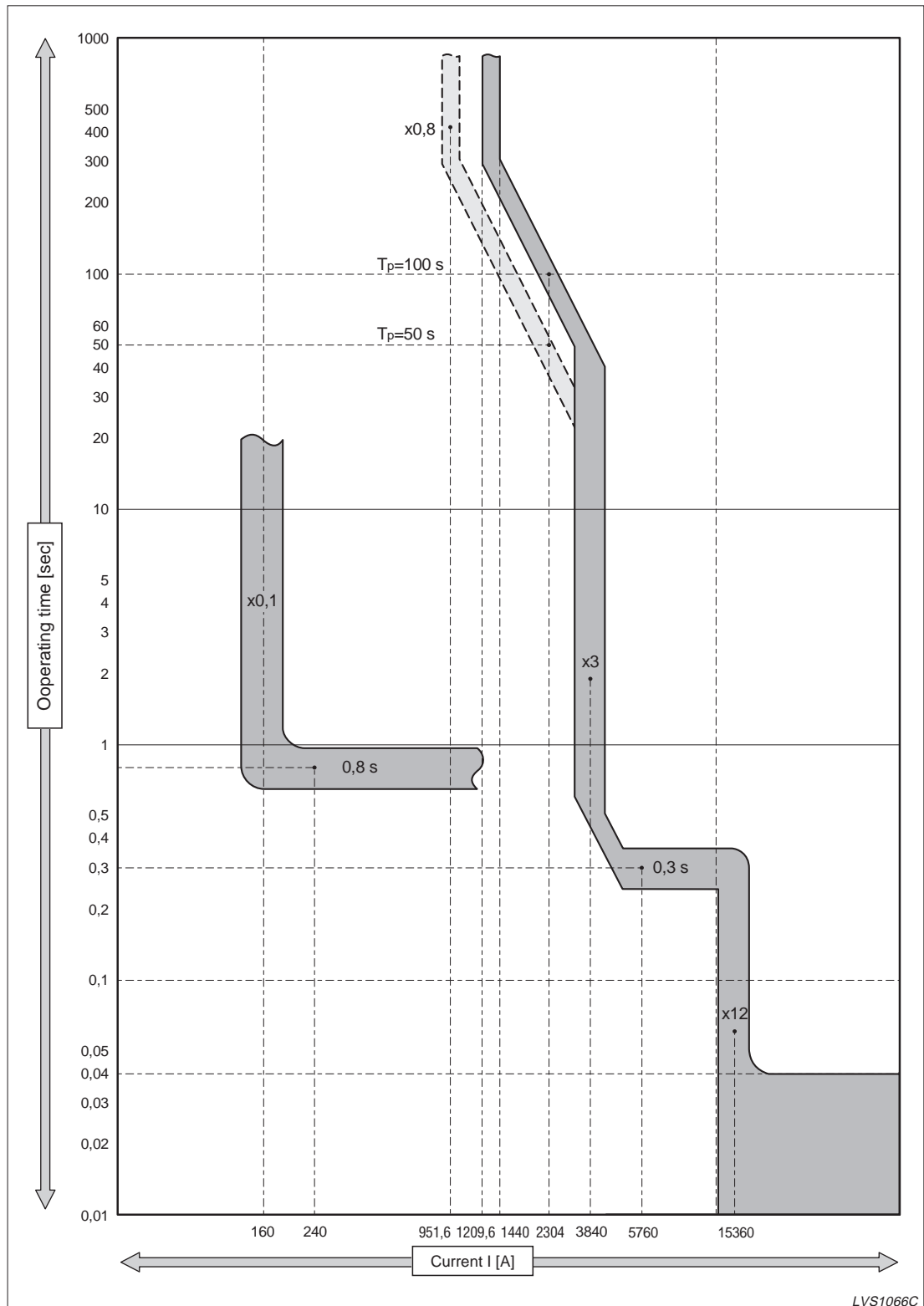

Fig. 3-13: Characteristics for the setting example

3.1.8 Operating system of each device

NOTE

| A circuit diagram of the electronic trip relay is shown on the next page.

① **Power supply CT**

Operation energy is supplied to the overcurrent tripping and ground fault tripping function (GFR) of the electronic trip relay.

② **Current sensor coil**

The current of each phase which flows in the breaker is detected. A coreless coil with good linearity is employed. The integrated circuit integrates the output voltage and bears the signal waveform which is in proportion with the load current.

③ **LTD circuit**

This is an effective value detection type which is strong against the distorted wave. It has a memory effect for the over-current state. If the electronic trip relay is tripped, the over-current memory is reset.

④ **Pre-alarm circuit**

This is an effective value detection system. As it does not have a memory effect for the over-current state, once the current becomes less than the value of the pre-alarm setting current, it is reset to the former state.

⑤ **STD/INST circuit**

This is a peak value detection system which is influenced by the distortion of the waveform.

⑥ **Ground fault circuit**

The signals in each phases are summed up in the vector mode in order to gain the ground fault value.

⑦ **Current measuring output circuit**

This is an effective value detection system. Since insulation amplifiers are used, it is insulated between the input and the output.

⑧ **OCR alarm circuit**

1 pulse 30 ms signal output without control power supply

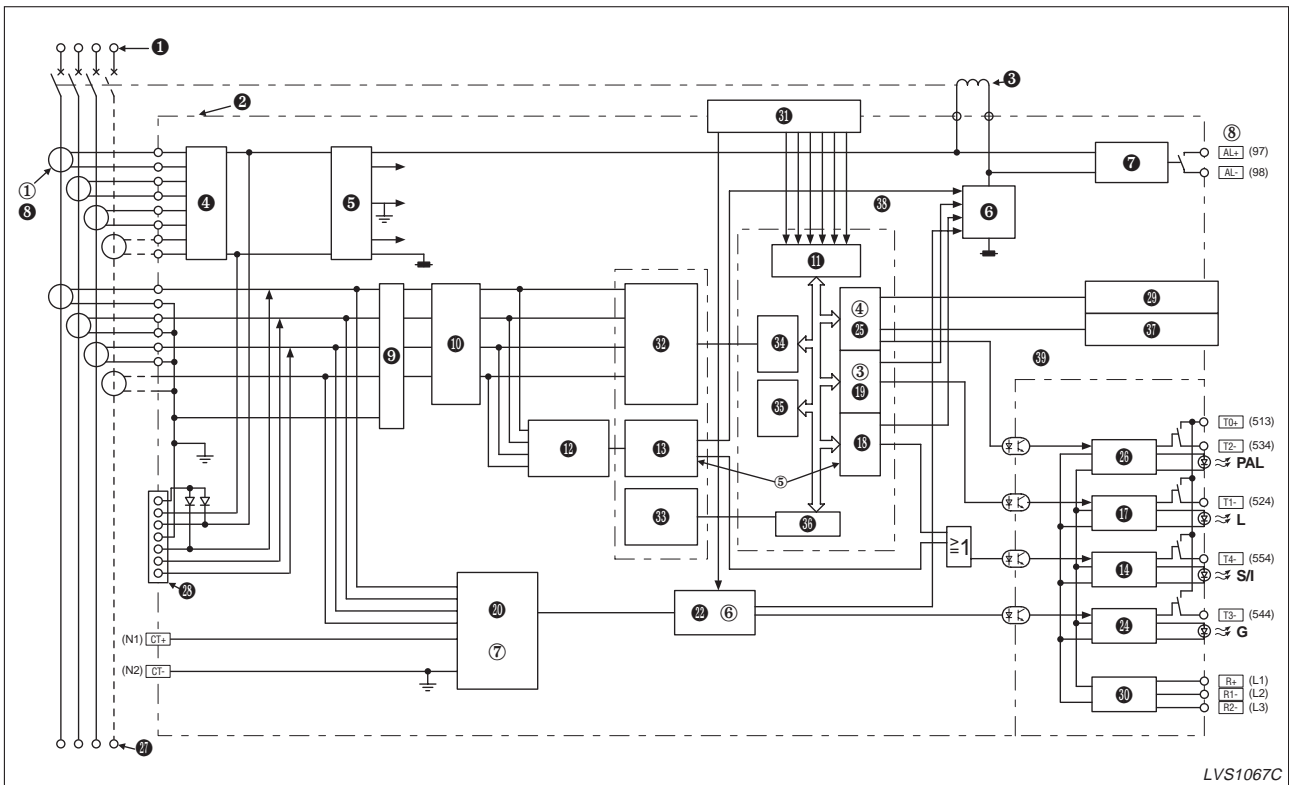

Fig. 3-14: Circuit diagram of the electronic trip relay (SPGT type)

Explanation for fig. 3-14

- | | |
|-------------------------------------|---------------------------------------|
| ① Power supply CT | ⑤ STD/INST circuit |
| ② Current sensor coil | ⑥ Ground fault circuit |
| ③ LTD circuit | ⑦ Current measurement output circuit |
| ④ Pre-alarm circuit | ⑧ OCR alarm circuit |
| ① Line side terminal | ②① Effective value conversion circuit |
| ② Electronic trip relay | ②② Ground fault circuit |
| ③ Trip coil | ②③ Current measuring output circuit |
| ④ Rectifier circuit | ②④ Ground fault indication circuit |
| ⑤ Power supply circuit | ②⑤ Pre-alarm circuit |
| ⑥ Trigger circuit | ②⑥ Pre-alarm output circuit |
| ⑦ OCR alarm circuit | ②⑦ Load side terminal |
| ⑧ Power supply CT | ②⑧ Test connector |
| ⑨ Integrating circuit | ②⑨ Load current indication LED |
| ⑩ Rectifier signal circuit | ③⑩ Control power circuit |
| ⑪ Characteristics setting circuit | ③① Setting switches |
| ⑫ Max. phase selecting circuit | ③② Phase selection conversion circuit |
| ⑬ INST circuit | ③③ Watch dog timer |
| ⑭ STD/INST indication circuit | ③④ A/D converter circuit |
| ⑮ Current sensor coil | ③⑤ Accumulator |
| ⑯ Peak value conversion circuit | ③⑥ I/O circuit |
| ⑰ LTD indication circuit | ③⑦ Pre-alarm indication LED |
| ⑱ STD circuit | ③⑧ CPU |
| ⑲ LTD circuit | ③⑨ Tripping circuit |
| ⑳ Integration / composition circuit | ④⑩ Common IC |

3.2 Checking the tripping characteristics

3.2.1 Checking with a field tester (Y-160 and Y-2000)

If the test power supply or the simulation signal is applied to the test terminals of the electronic trip relay, the overcurrent tripping characteristics or ground fault operating characteristics can easily be measured.

Two models are available:

- Model Y160 is a small battery type.
- Model Y-2000 which can measure all the characteristics.

NOTE

If any current flows in the main circuit of the breaker, the proper characteristics will not be measured since the current will distort the simulation signal of the test. Therefore, ensure that the test is conducted when the load current does not exist in the main circuit.

In order to remove any influence which may result from energization before the test, trip the breaker once with the trip check before measuring the LTD time.

The instantaneous tripping current is the value measured when the breaker is tripping, gradually by increasing the overcurrent signal (OS) during pressing the switch "STD LOCK" (when model Y-2000 is used).

3.2.2 Checking with the Y-160

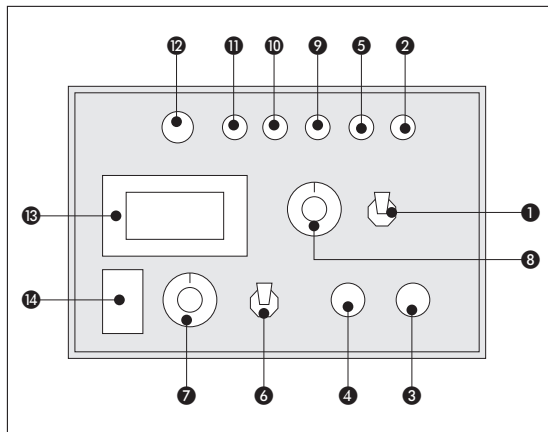

Fig. 3-15:
Checking with the Y-160

LVS0125C

- | | |
|---------------------|------------------------|
| ① POWER switch | ⑧ ROTARY switch |
| ② LED | ⑨ LED |
| ③ START switch | ⑩ LED |
| ④ STOP switch | ⑪ BATTERY CHECK LED |
| ⑤ LED | ⑫ BATTERY CHECK switch |
| ⑥ SET switch | ⑬ TIME COUNTER |
| ⑦ TRIP CHECK switch | ⑭ TEST CONNECTOR |

Set-up

- ① Insert the test connector ⑭ into the test terminal of the electronic trip relay.
- ② Turn on the POWER switch ① on the front panel. The LED will come on to indicate that the test power supply has been turned on.

Battery check

- ① Set the switch ⑥ to TEST (upper side).
- ② Press the STOP switch ④ and then the BATTERY CHECK switch ⑫ to check the battery.
- ③ The test can be conducted as soon as the BATTERY CKECK LED ⑪ has lit up. The LED ⑤ also lights up.

NOTE

If the BATTERY CKECK LED ⑪ does not light up, the power supply capacity of the test circuit is insufficient. In this case, connect the unit to a suitable az supply or recharge it before using.

Trip check

- ① Set the switch ⑥ to TRIP CHECK (lower side) (the rotary switch ⑦ can be set to any position).
- ② Press the START switch ③ to carry out a trip check.
- ③ When the LEDs ⑤ and ⑨ are lit up, the electronic trip relay is operative and trips. After that, the LEDs ⑤ and ⑨ go out. The TIME COUNTER ⑬ now shows the operating time which, however, is insignificant. To test the operating time, follow procedure ④.

Over-current test

- ① Set the switch ⑥ to TEST (upper side).
- ② Set the ROTARY switch ⑦ to S1.
- ③ Set the signal level with the ROTARY switch ⑧.
- ④ Press the START switch ③ so that the LED ⑤ lights up and the over-current test starts.
- ⑤ When the electronic trip relay is operative and trips, the LED ⑤ goes out, the LED ⑩ lights up and the time counter ⑬ stops to show the over-current pick-up time. With that, the over-current test is completed.

NOTES

Recheck the battery, as a battery failure during the over-current test may cause an incorrect operating time to be displayed.

If, even after the operating time given in table 3-6 has expired, the electronic trip relay has not operated, there may be a problem with the contacts of the TEST CONNECTOR ⑭. If so, press the STOP button ④ to stop the test and then check the contacts of the connector.

| Setting of rotary switch ⑧ | Operating time ⑨ |
|--|------------------|
| 2000 % | 0.0 – 0.2 sec. |
| 500 % | 0.1 sec. ± 20 % |
| 200 % | 50 sec. ± 20 % |
| 125 % | 128 sec. ± 20 % |
| [Electronic trip relay setting $I_N = 1.0$; $T_L = 50$ sec] | |

Tab. 3-6:
Operating times

Earth test

- ① Set the switch ⑥ to TEST (upper side).
- ② Set the rotary switch ⑦ to S2.
- ③ Select the signal level with the rotary switch ⑧ according to table 3-7.

| Ground fault pick-up | Setting of rotary switch ⑧ |
|------------------------------|----------------------------|
| $0.1 \times I_N \text{ MAX}$ | 20 % |
| 0.2 | 50 % |
| 0.3 | 50 % |
| 0.5 | 125 % |

Tab. 3-7:
Signal levels

- ④ Press the START switch ③. When the LED ⑤ lights up, the ground fault test starts.
- ⑤ When the electronic trip relay operates and trips, the LED ⑤ goes out, the LED ⑩ lights up, and the time counter ⑬ stops showing the ground fault pick-up time (GFR TIME). With that, the ground fault pick-up test is completed.

NOTE

Set the ground fault trip alarm switch to trip.

Recharging

- ① Turn off the POWER switch ①.
- ② Connect the AC power supply cable to the connector provided on the rear panel and apply the rated voltage.
- ③ 14 to 16 hours of recharging allows the field tester to be 100 % recharged and to run continuously for about 90 minutes.

NOTE

Even if the battery is discharged, tests can be made using the AC power supply. The AC voltage to be applied should be within +10 % and -15 % of the nominally rated voltage. If the battery is completely discharged, recharge it for about 20 minutes and apply the AC power supply to the field tester.

Other information

- The time shown on the time counter is retained until the START switch ③ is pressed or until the POWER switch ① is turned off and then on again.
- Life of the time counter is about 10 years.
- During storage, keep the POWER switch ① turned off.

Advices for battery recycling

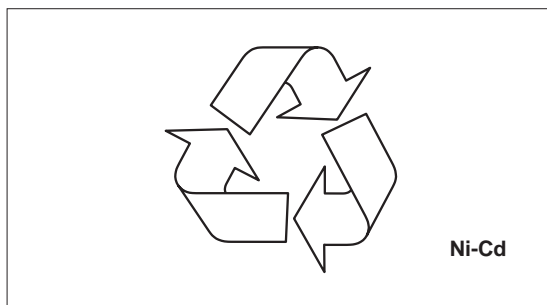

Fig. 3-16:

The Y-160 includes a Ni-Cd battery, which must be specially recycled after used.

LVS1068C

- The Y-160 is powered with a nickel-cadmium battery. Nickel-cadmium batteries are very important recyclable material. Before disposing devices with nickel-cadmium batteries (or when replacing nickel-cadmium batteries with new ones), make sure to remove the nickel-cadmium batteries and turn them over to an appropriate organization for recycling.
- In order to prevent shorting the nickel-cadmium battery terminals, cover the terminals with an insulating tape, and store the battery making sure not to mix with other batteries.

3.2.3 Checking with the Y-2000

The Y-2000 type breaker tester is a light weight portable diagnostic device which is designed to test the tripping characteristics of the AE-SS series air circuit breakers.

Testing is possible anywhere at any time and regardless of whether or not the breaker is connected to a line supply.

| Specifications | |
|------------------------|--------------------------------------|
| Power supply | AC 100 – 240 V; 50 – 60 Hz |
| Output signal | 0 ~ 2500 % (continuously adjustable) |
| Time counter | 0.000 ~ 989.999 sec. |
| Dimensions (W x H x D) | 230 x 120 x 290 |
| Attachments | Power input wire, test lead wire |

Tab. 3-8: Specifications for Y-2000

Description of the outside

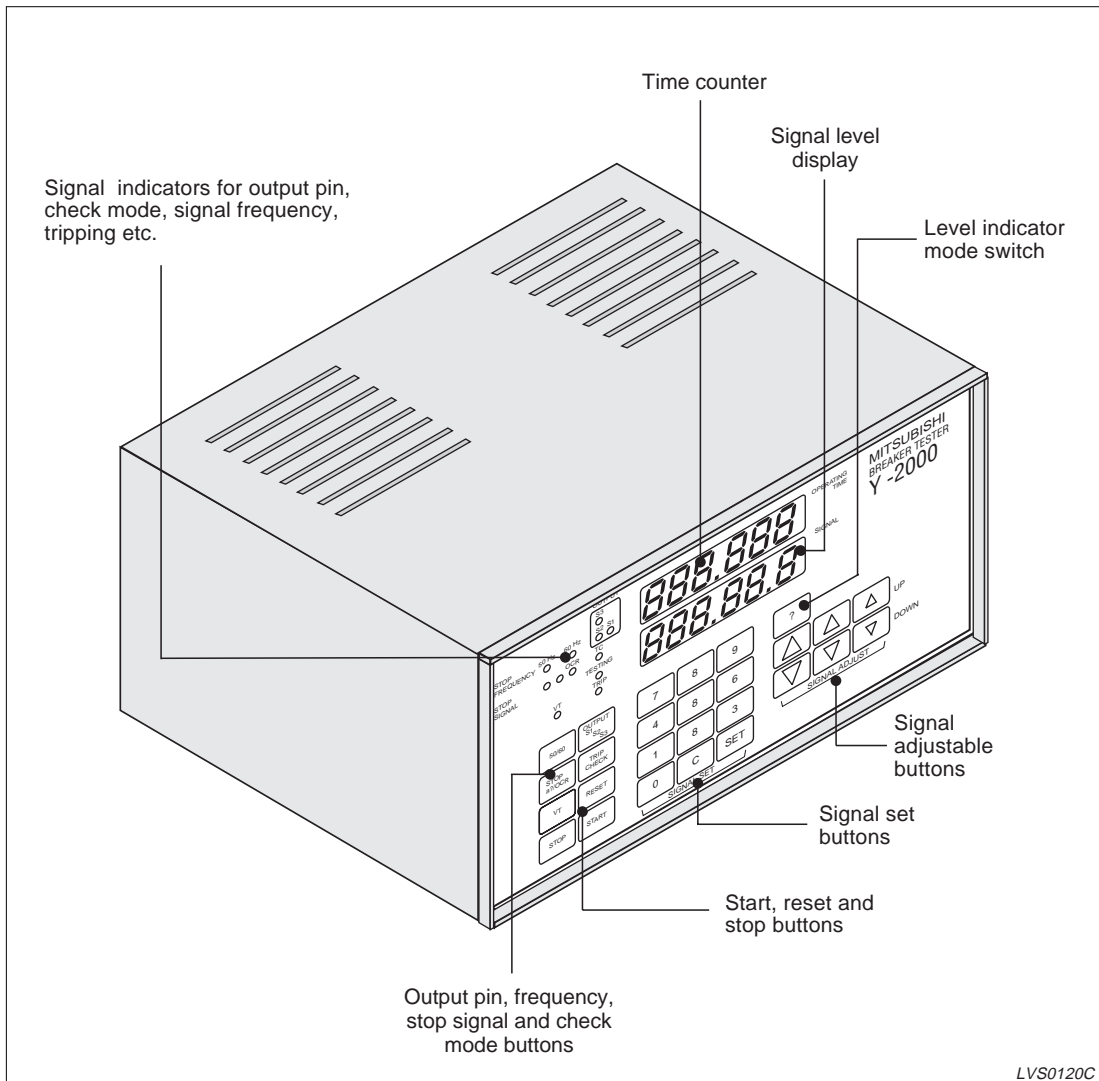

Fig. 3-17: Description of the outside

Preparation of the test

- ① Remove the front cover by pulling at the two black knobs.
- ② Connect the wire.
- ③ Set the time counter and the signal level by turning on the power switch at the back panel. The LED lights up.
- ④ Set the test mode with the following switches. By pushing these switches, you select the different modes.
 - Signal frequency 50 Hz, 60 Hz
 - Stop signal a, b, OCR
 - Output pin S1, S2, S3
 - Check mode Usual test, Trip check

(When the power is turned on, each mode is set on the marked position.)

⑤ Setting of the rated current I_N

At first, set the rated current I_N to the rated current of the electronic trip relay, because the signal level is represented in % of the rated current I_N .

When the power is turned on, I_N is $1 \times I_{NMAX}$.

- Set the mode (...) by using the level indicator mode switch (...), adjust the rated current I_N to 0.4 – 1 of the max. rated current I_{NMAX} by using the signal adjustable switch or the signal set switch.

$$\begin{aligned} \text{Rated current } I_N &= 0.8 \times I_{N,MAX} \\ \text{Uninterrupted current } I_U &= 1 \times I_{N,MAX} \end{aligned}$$

H 0.800

- When the uninterrupted current I_U is not $1 \times I_N$, set in case of measuring long-time-delay and pre-alarm characteristics as follows.

$$\begin{aligned} \text{Rated current } I_N &= 0.5 \times I_{N,MAX} \\ \text{Uninterrupted current } I_U &= 0.8 \times I_N = 0.4 \times I_{N,MAX} \end{aligned}$$

H 0.400

When the uninterrupted current I_U is not $1 \times I_N$, set the rated current value I_N even at any I_U setting for STD and INST.

$$\begin{aligned} \text{Rated current } I_N &= 0.5 \times I_{N,MAX} \\ \text{Uninterrupted current } I_U &= 0.8 \times I_N = 0.4 \times I_{N,MAX} \end{aligned}$$

H 0.500

- When measuring ground fault characteristics, adjust I_N to $1 \times I_{NMAX}$.

H 1.000

Test

- ① Set the mode (...) by using the level indicator mode switch [X_{INMAX}/%I_N].
- ② Adjust the signal level to the desired value in % of the rated current I_N (for adjusting the signal level refer to prescribed paragraph) by using the signal adjustable switch or the signal set switch.

When using the signal adjustable switch

When pushing the switch, the signal level is counted up or down continuously.

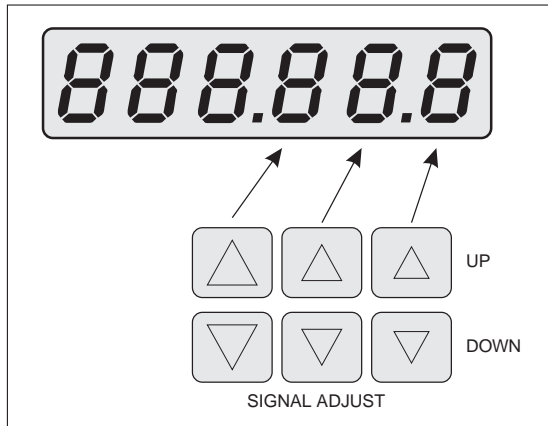

Fig. 3-18:
Testing with the signal adjustable switch

LVS0126C

When using the signal set switch

- Push the clear key C.
- The figures are shifted to the left each time you push a numerical key. Use the numerical keys to indicate the desired value.
- Push the set key SET.

Example ▽ Adjust the signal to 200 % by pushing C 2 0 0 0 0 SET. The following is displayed: 02000,0.



- ③ Push the START switch. The test signal starts generating, the time counter starts counting up from zero and the test mode indicator "TESTING" lights up.
- ④ Push the STOP switch. The Test signal stops generating, the time counter stops counting at the last value and the test mode indicator "TESTING" goes out.
You can use this switch to quit testing at any time.
- ⑤ When the electronic trip relay is released, the trip indicator of this tester lights up and the time counter stops. The operating time is indicated on the time counter.
- ⑥ Push the RESET switch to reset the time counter and the trip indicator "TRIP" of this tester. Then re-start becomes to enable.



CAUTION:
When the test is stopped mid-way, trip the breaker with the "trip check" mode and repeat the test.
You can shorten the operating time by testing again without tripping the breaker.

4 Accessories

This chapter describes the replacement of the accessories or the mounting of additional accessories for the breaker.

4.1 Preparing the breaker



DANGER:

When working or servicing at the breaker first of all remove the control supply to prevent an electric shock. Never maintain the breaker in the CONNECTED position with the power supply switched on. Replace the accessories when the breaker is opened and in DISCHARGED and OFF position to prevent being injured by unexpected movement.

- ① Remove the cover of the breaker (refer to Fig. 4-1).

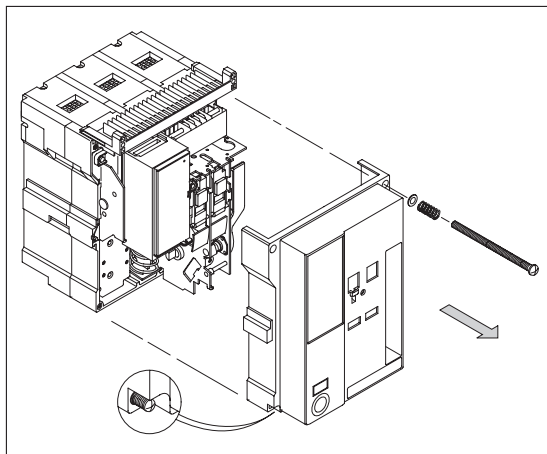
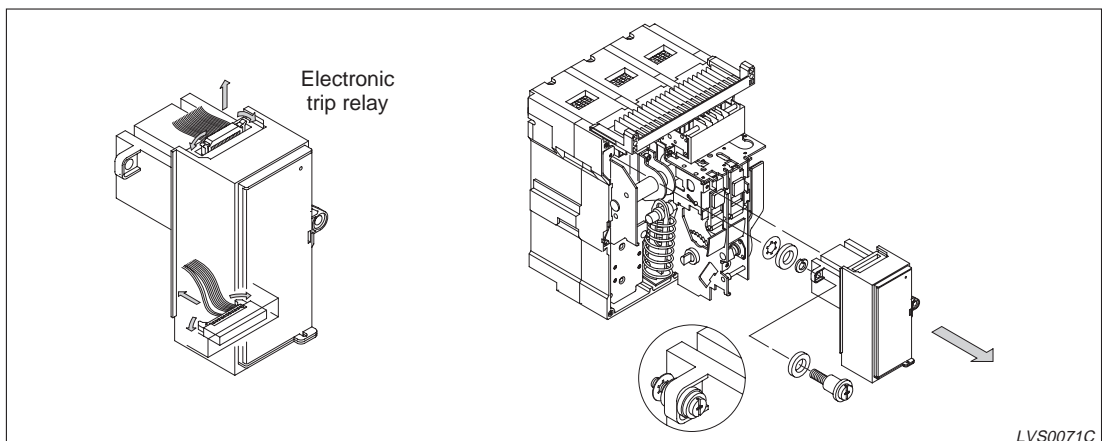

Fig. 4-1:
Removal of the breaker cover

LVS0070C

- ② If the counter CNT or a OFF lock device (CAL, CYL) are required, knock out the cover in accordance with the manual (refer to para. 4.8 – 4.10)
- ③ For some installation matters (**for trained service only!**) you need to remove the electronic trip device. Refer to Fig. 4-2 for the correct de-installation.



LVS0071C

Fig. 4-2: Removal of the electronic trip relay (**for trained service personal only!**)

4.1.1 Overview

The following paragraphs contain information about the removal and installation of the following accessories:

| | | |
|-----|--------------------------|--------------------|
| AX | Auxiliary switch | refer to para 4.2 |
| SHT | Shunt trip device | refer to para 4.3 |
| CC | Closing coil | refer to para 4.4 |
| UVT | Undervoltage trip device | refer to para 4.5 |
| MD | Motor charging device | refer to para 4.6 |
| CL | Cell switch | refer to para 4.7 |
| CYL | Cylinder lock | refer to para 4.8 |
| CAL | Castell lock | refer to para 4.9 |
| CNT | Counter | refer to para 4.10 |

Furthermore, you will find information about various safety devices and other accessories:

| | | |
|------|-------------------------------|---------------------|
| SST | Safety shutter | refer to para. 4.11 |
| SBC | Shorting b-contact | refer to para. 4.12 |
| MIP | Mis-insertion preventor | refer to para. 4.13 |
| MI | Mechanical interlock | refer to para. 4.14 |
| DI | Door interlock | refer to para. 4.15 |
| TJ | Test jumper | refer to para. 4.16 |
| ZCT | External ZCT for load circuit | refer to para. 4.17 |
| BC-L | Push-button cover | refer to para. 4.18 |
| FTA | Front terminal adapter | refer to para. 4.19 |
| VTA | Vertical terminal adapter | refer to para. 4.20 |

4.2 Auxiliary switch (AX)

4.2.1 Removal

- ① Remove the SHT, CC and UVT.

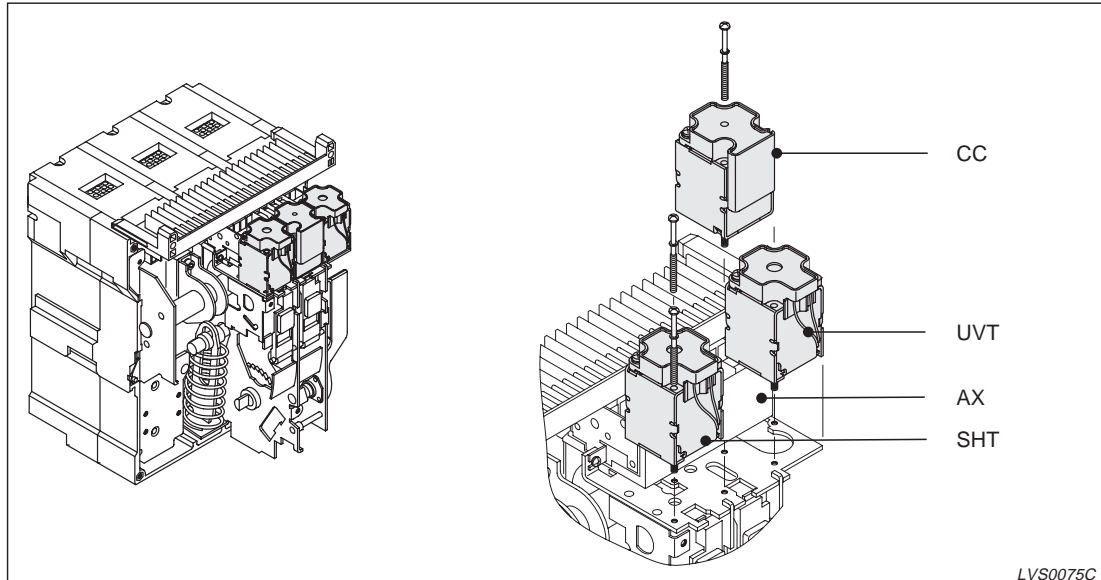

Fig. 4-3: Removal of SHT, CC and UVT

Pull out the faston terminals of the SHT, CC and UVT from the control circuit connector.

For further details refer to the following:

SHT ... para. 4.3; CC ... para. 4.4; UVT ... para. 4.5.

- ② Remove the M4 AX mounting screw.
- ③ Pull out the faston terminal which connects the AX to its control circuit connector.

NOTE

Do not pull directly at or damage any lead wire during the removal.

- ④ To remove the auxiliary switch, pull its left hand side toward you.

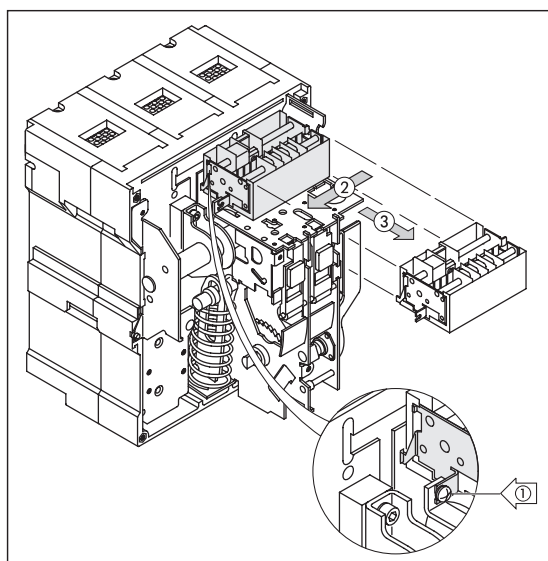

Fig. 4-4: Removal of the auxiliary switch

LVS0072C

4.2.2 Installation



CAUTION:

Do not touch the breaker mechanism, as this may cause injury.

- ① As shown in fig. 4-5, insert the AX from the front, and engage the projection on the right hand side into the joint of the mechanism.
- ② Insert the projection (see fig. 4-5) on the left hand side into the hole of the insulated base, and align the position of the AX being fitted with its operating mechanism.

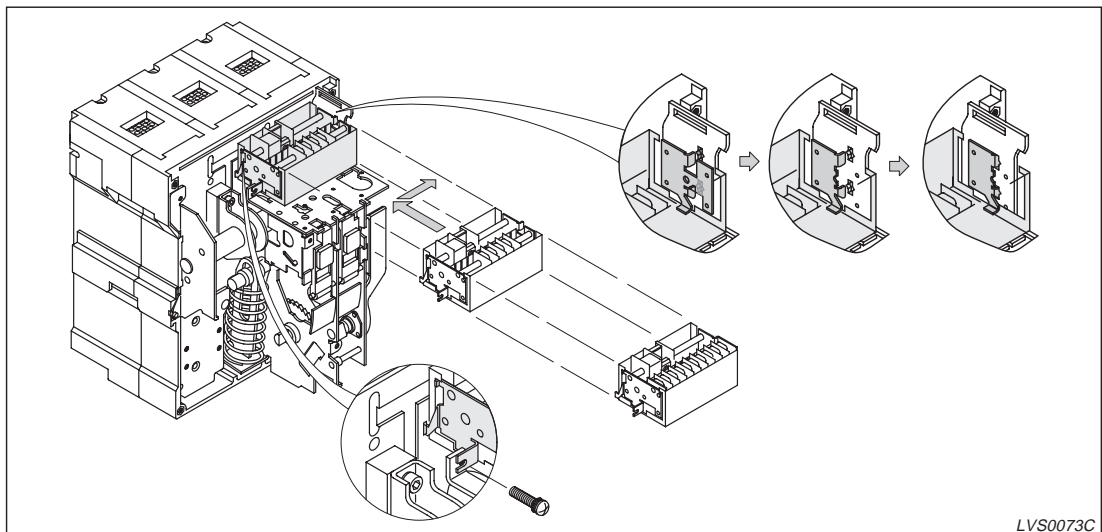

LVS0073C

Fig. 4-5: Removal of the auxiliary switch

- ③ Fasten the AX with the mounting screw (M4).
- ④ The wire mark must correspond to the terminal mark of the control circuit connector. Insert the faston terminal (see fig. 4-6).

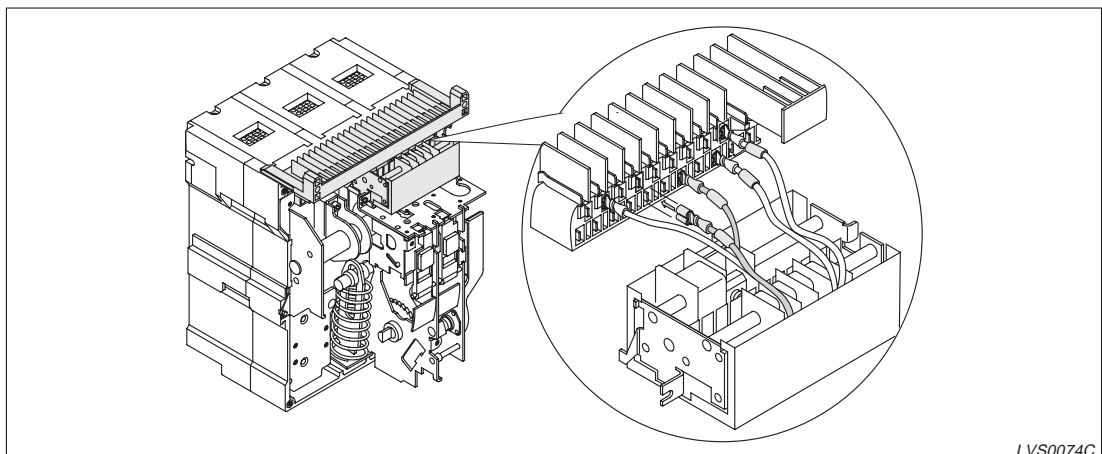

LVS0074C

Fig. 4-6: Wiring of the auxiliary switch

- ⑤ Close and open the breaker, and make sure that the AX is operating correctly.

4.3 Shunt trip device (SHT)

4.3.1 Removal

- ① Remove the two M4 mounting screws as shown in fig. 4-3.
- ② Release the lock of the connector, and remove the connector (fig. 4-7).

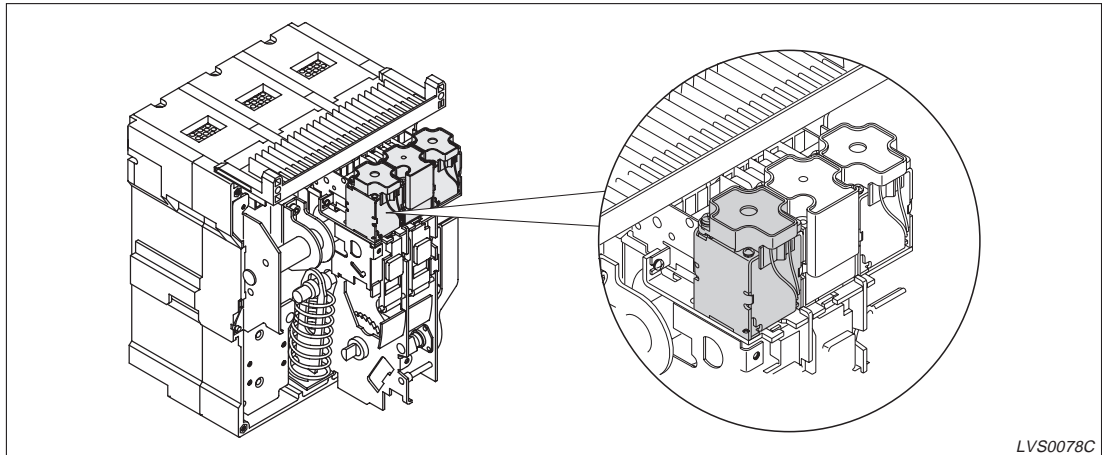

Fig. 4-8: Location of the shunt trip device

4.3.2 Installation



CAUTION:
Do not touch the breaker mechanism, as this may cause injury.

- ① Insert the connector securely (fig 4-8).
(Make sure that the connector lock is aligned and engaged).
- ② Tighten the two M4 mounting screws to install the device in the correct position. (The mounting position is on the left hand side of the mechanism.)
- ③ Close the breaker, and make sure that the breaker is tripped by applying 70 % of the rated voltage to the SHT.

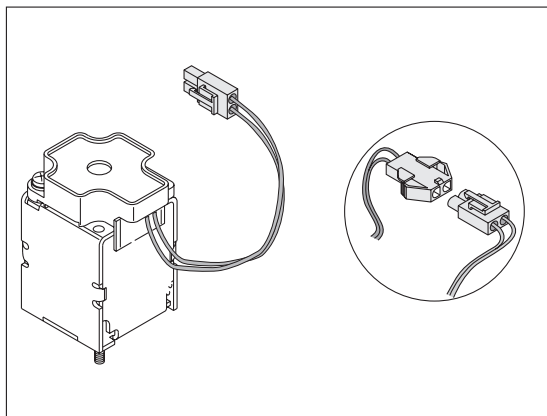

Fig. 4-7:
Connection of the shunt trip device

LVS0076C

4.4 Closing coil (CC)

4.4.1 Removal

- ① Remove the two M4 mounting screws as shown in fig. 4-3.
- ② Pull out the faston terminals of the CC from the terminals CC+ (A1) and CC- (A2) of the control circuit connector.

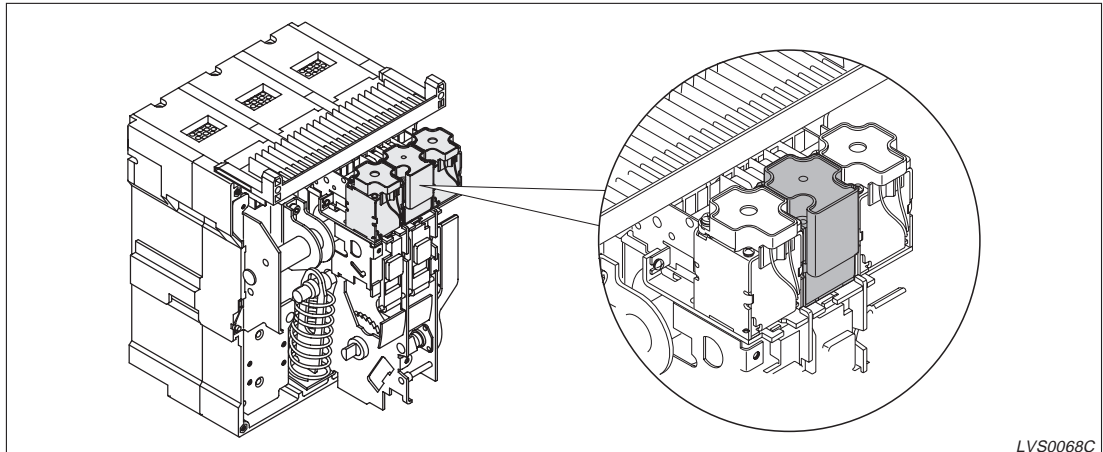

Fig. 4-9: Location of the closing coil

NOTE

Do not pull directly at or damage any lead wires during the removal. Mounting and removal of the faston terminal is easy when the SHT is removed.

4.4.2 Installation



CAUTION:

Do not touch the breaker mechanism, as this may cause injury.

- ① Insert the faston terminals CC+ (A1) and CC- (A2) into the control circuit connector in accordance with the terminal marks.
- ② Tighten the two M4 mounting screws to install the device in the correct position. (The mounting position is at the center of the mechanism.)
- ③ Charge the circuit breaker after opening and apply AC 85 % or DC 75 % of the rated voltage to make sure that the breaker will be closed.

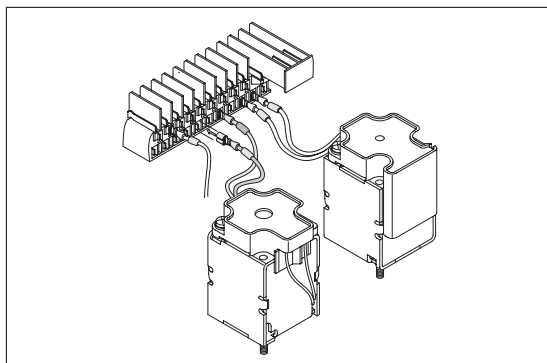

Fig. 4-10:
Installation of the closing coil

LVS0077C

4.5 Undervoltage trip device (UVT)

4.5.1 Removal of the coil

- ① Remove the two M4 mounting screws as shown in fig. 4-3.
- ② Pull out the faston terminals of the UVT from the terminals U+ (J1) and U- (J2) of the control circuit connector.

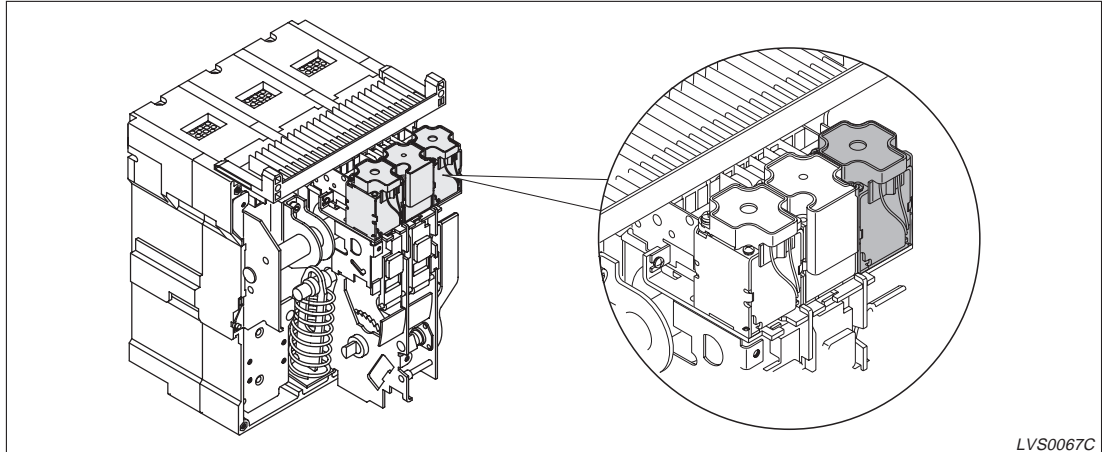

Fig. 4-12: Location of the undervoltage trip device

NOTE

Do not pull directly at or damage any lead wires during the removal. Mounting and removal of the faston terminal is easy when the SHT is removed.

4.5.2 Installation of the coil



CAUTION:

Do not touch the breaker mechanism, as this may cause injury.

- ① Insert the faston terminals U+ (J1) and U- (J2) into the control circuit connector in accordance with the terminal marks.
- ② Tighten the two M4 mounting screws to install the device in the correct position. (The mounting position is on the right side of the mechanism.)
- ③ In order to check the operation, refer to the description of the UVT controller in para. 4.5.4.

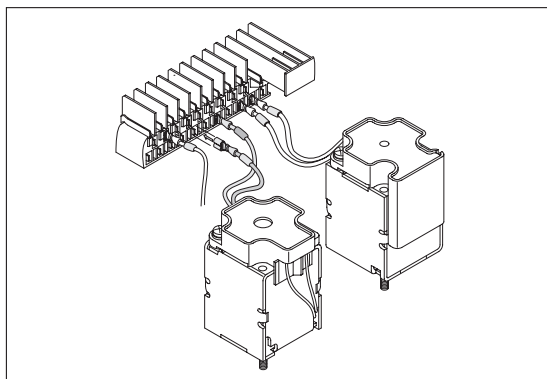

Fig. 4-11
Installation of the UVT coil

LVS0077C

4.5.3 Removal of the controller

- ① Remove the lead wires from the UVT controller and from the control circuit terminal block.
UL0–UL3 (D1–D4), U+ (J1), U- (J2)
- ② Hold the UVT controller and loosen the two mounting screws. Release the fixing plate 2 (refer to fig. 4-13) from the side plate of the breaker, and remove the UVT controller.

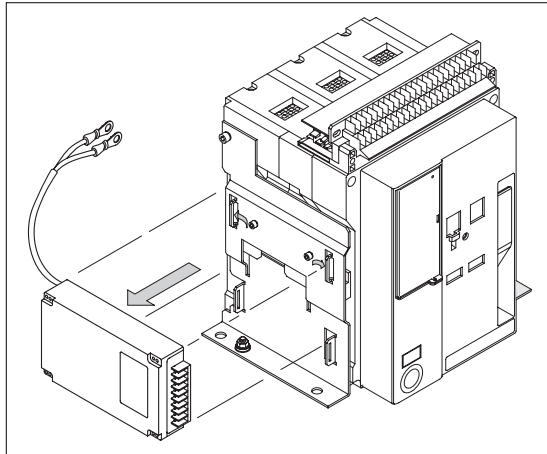
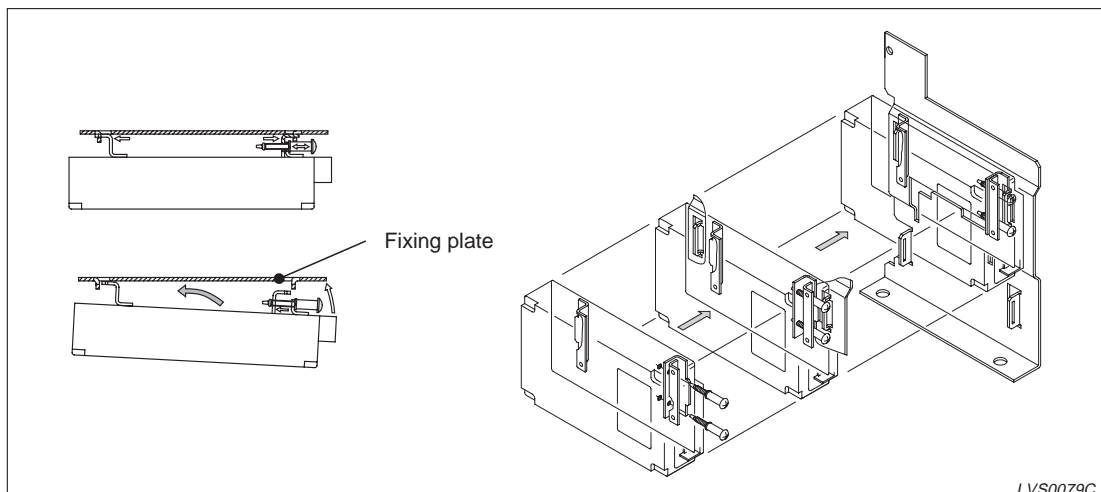

Fig. 4-14:
Removal of the UVT controller

LVS0066C

4.5.4 Installation of the controller

- ① Insert the fixing plate 1 of the controller into the side plate of the breaker, and tighten the two mounting screws to securely fix the fastener 2 in the hole on the side plate of the breaker.



LVS0079C

Fig. 4-13: Mounting the UVT controller

- ② Connect the power supply UL0–UL3 (D1–D4), the trip terminals US+ (DT1), US- (DT2) and the lead wires U+ (J1), U- (J2) to the control terminal block U+ (J1), U- (J2) according to the circuit diagram in fig. 4-15.



CAUTION:
Wire the external circuit correctly according to fig. 4-15 and 4-16, otherwise there are the possibilities of malfunction, non-operation or damage to the UVT by overvoltage.

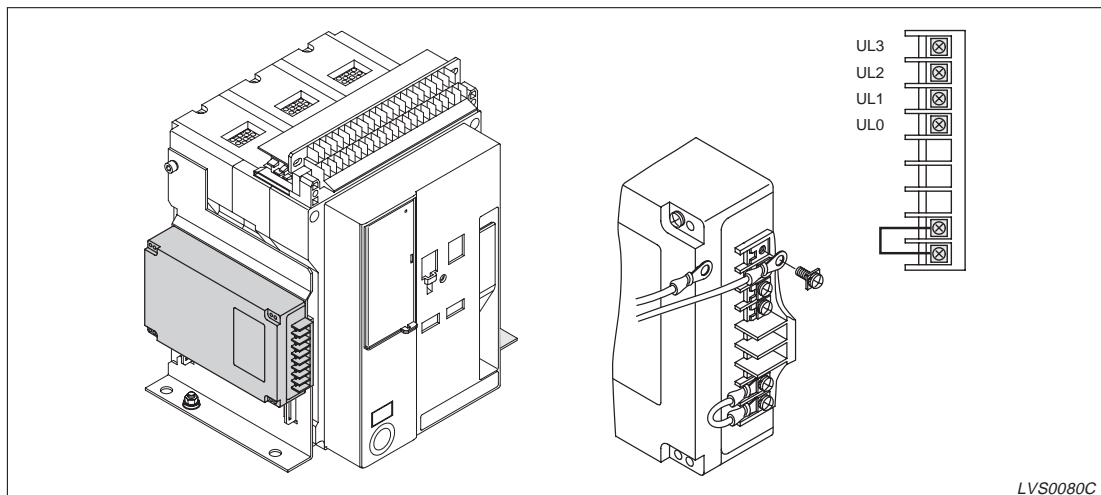

Fig. 4-15: Connection of the UVT controller

- ③ Apply 85 % of the rated voltage (lower rated value in case of voltage rating) to the UVT controller in order to pick up the UVT coil. After closing the breaker, make sure that the breaker will trip when US+ (DT1) and US- (DT2) are open with the trip button.

NOTE

The maximum distance between UVT controller and trip button is 5 meters by 1,5 mm² copper wire.

- ④ In the same way, after closing the breaker, make sure that the breaker is open when the applied voltage is dropped to less than 50 % of the rated voltage.

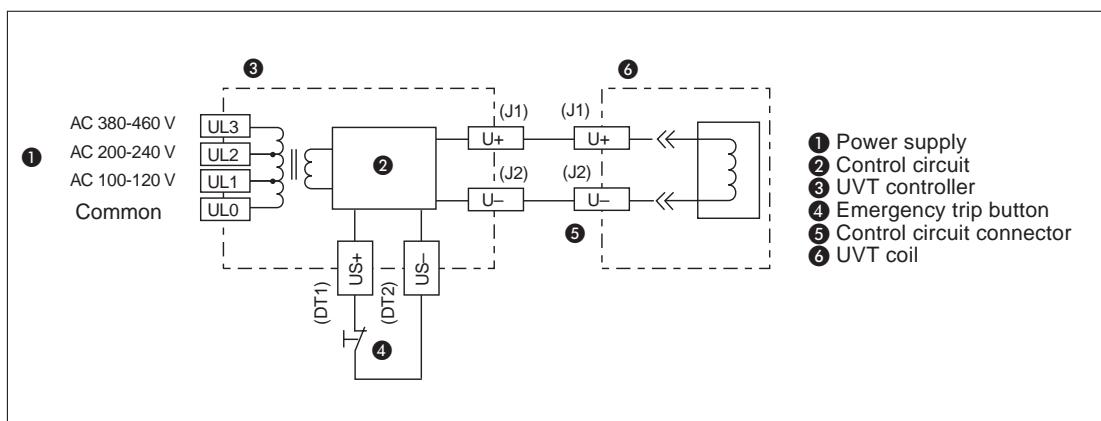

Fig. 4-16: Circuit diagram of the UVT

NOTE

In case of dielectric test to panel board remove the source wire UL0–UL3 (D1–D4) from the UVT controller before starting the test operation.

4.6 Motor charging device (MD)

4.6.1 Removal



DANGER:

Make sure that the control supply is removed before removing the motor charging device.

- ① If the counter (CNT) or the OFF lock device (CAL; CYL) are provided, remove them (two M6 screws) before dismantling the motor charging device. Remove the two M6 mounting screws of the motor charging unit (fig. 4-17).
- ② Draw out the motor charging unit sideways from the shaft.

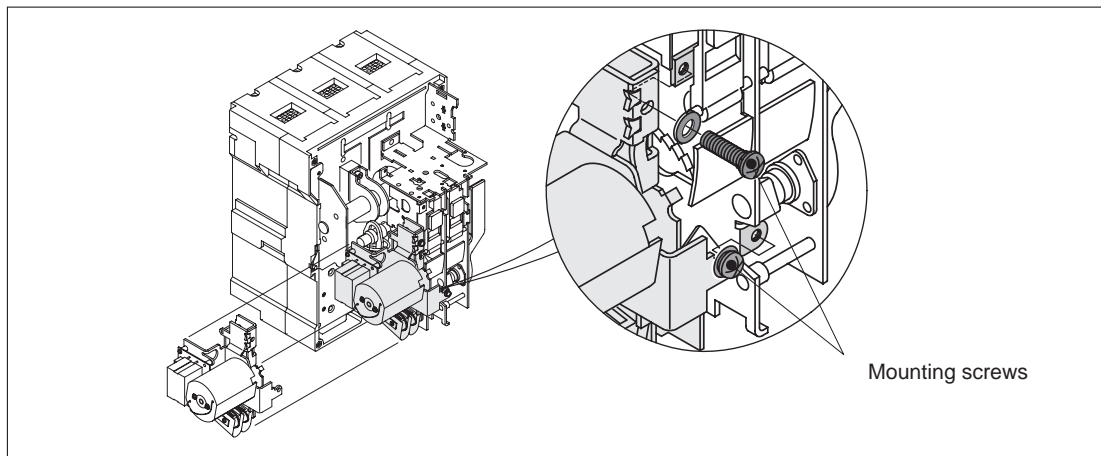

Fig. 4-17: Removal of the motor charging device

- ③ Release the lock of the connector and remove the connector. Two kinds of connectors are provided for the charge completion (TS) and the motor control supply.

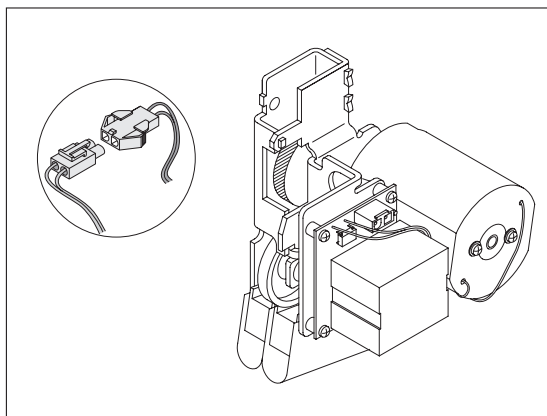

Fig. 4-18:
Removing the connector

LVS0081C



DANGER

When the motor charging device is dismantled, do never apply control power supply to the motor unit. This may cause minor injury or an electric shock.

4.6.2 Installation



CAUTION:
Do not touch the breaker mechanism, as this may cause injury.

- ① If the CNT, CAL or CYL are provided, remove them (two M6 screws) before installing the motor charging unit.

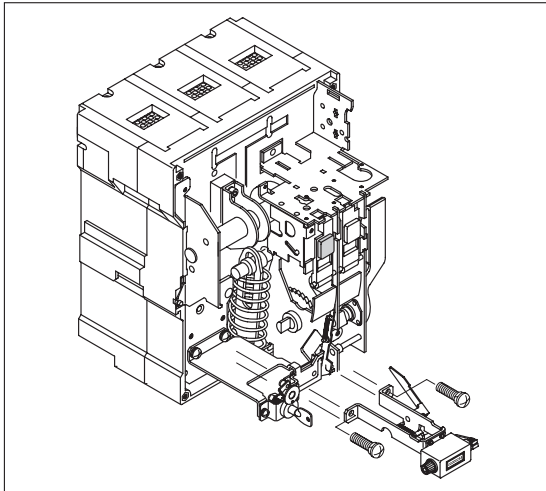

Fig. 4-19:
Remove any accessory around the motor charging device before installing it

LVS0131C

- ② Make sure that the driving cam shaft is latched to the projection of the motor frame (fig. 4-20). If not so, turn the gear to latch the driving cam shaft with the projection.

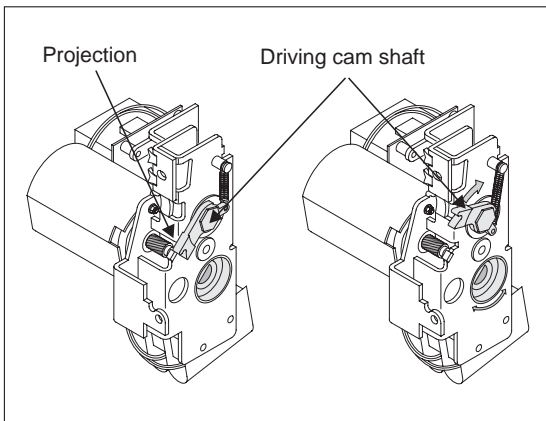

Fig. 4-20:
Take care of the correct cam shaft position before mounting

LVS0084C

- ③ Securely insert the connector to the motor charging unit. Make sure that the connector lock is engaged.

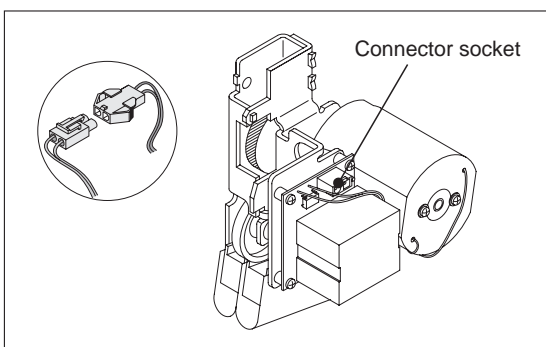

Fig. 4-21:
Connect the motor wire

LVS0081C

- ④ Align the notch of the cam and the cam shaft, and insert the cam into the cam shaft as shown in fig. 4-22.

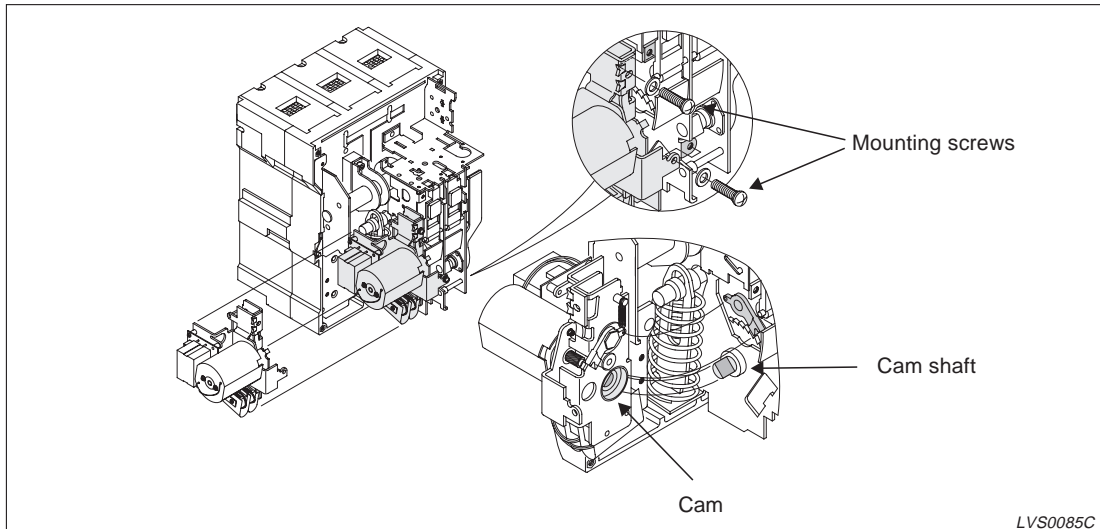

Fig. 4-22: Mounting the motor charging device

- ⑤ Install the motor charging unit with the two M6 mounting screws.
- Apply 85 % of the rated voltage to the MD and make sure that motor charging is possible. After the charging is completed, check the output of the TS signal.

4.7 Cell switch (CL)



DANGER:

When installing or removing the cell switch remove the mains power supply and the control supply to prevent an electric shock. Never maintain the cell switch in the CONNECTED position with the power supply switched on!

4.7.1 Removal

- ① Draw out the breaker from the cradle.
- ② Remove the two M5 mounting screws and remove the CL unit.
- ③ Remove the lead wires from the CL.

4.7.2 Installation

- ① Align the terminal marks and connect the lead wires to the CL in accordance with the terminal marks.
- ② Install the CL unit on the angle frame of the cradle with two M5 mounting screws.

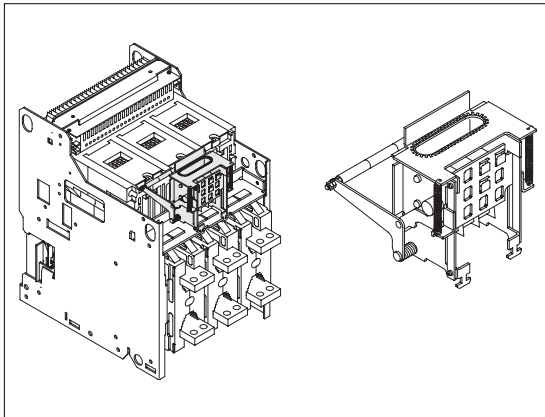

Fig. 4-23:
Removal and installation of the cell switch

LVS0086C

- ③ Insert the breaker into the cradle, and make sure that each cell switch is changed at the specified drawout position (CONNECTED, TEST, DISCONNECTED).

| Drawout position of the breaker | | Disconnected | Connected |
|---------------------------------------|---------------------|--|-----------|
| Display position of drawout operation | | Disconnected position Operating position DISCONNECTED TEST CONNECTED | |
| Switch function | CL-C (CONNECTED) | | |
| | CL-T (TEST) | | |
| | CL-D (DISCONNECTED) | | |
| Change-over sequence | | | |

Tab. 4-1: Operating sequence of the cell switch

4.7.3 Mounting of the CL adaptor

The CL adaptor is necessary when a cell switch (CL) should be mounted on a SH type breaker. The correct mounting position of the CL adaptor is shown in the following figures.

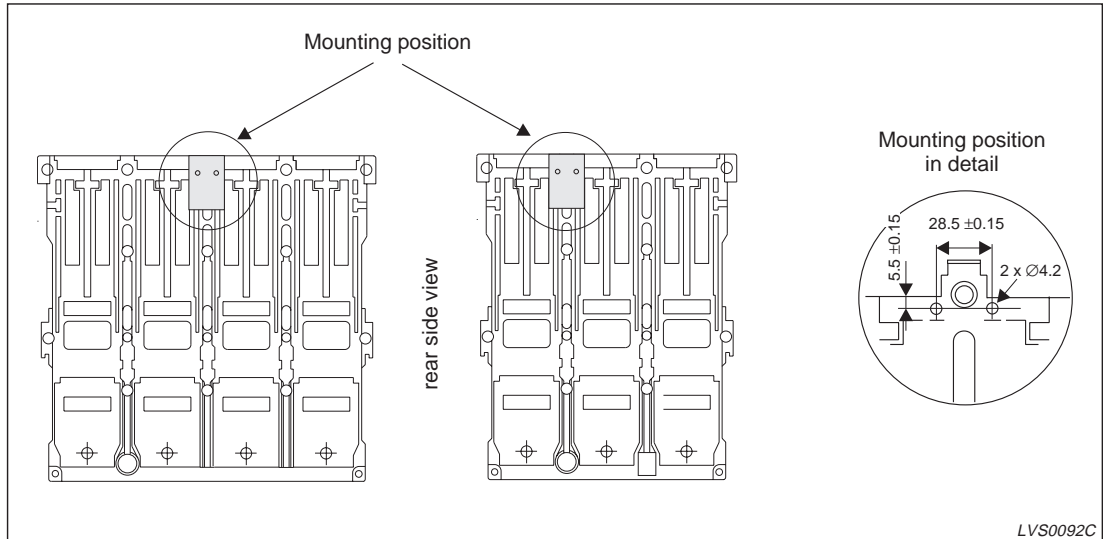

Fig. 4-25: Mounting position for the adaptor

To mount the adaptor, place it on the backside of the breaker and fix it with two M5 x 35 tapping screws (tightening torque 2.5~3.5 Nm).

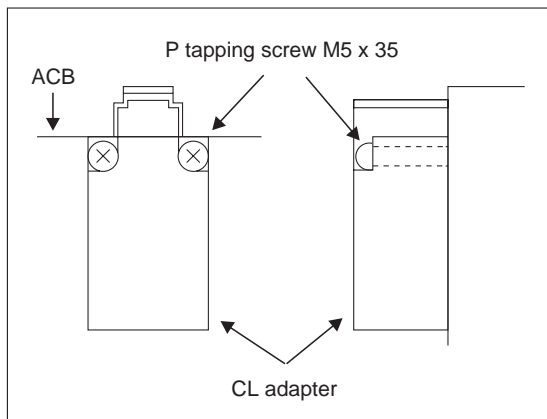

Fig. 4-24: Mounting the adaptor

LVS0096C

4.8 Cylinder lock (CYL)



CAUTION:
Be careful in handling the breaker inside. Do not touch the breaker mechanism as this may cause injury.

4.8.1 Removal

When the cylinder lock is in the release position with the OFF button pressed, remove the two M6 mounting screws which hold the key unit.

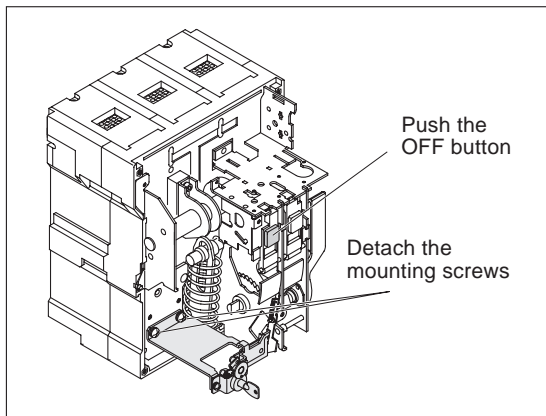

Fig. 4-26:
Removal of the cylinder lock

LVS0090C

4.8.2 Installation

- ① Set the breaker in the DISCHARGED and OFF position.
- ② Turn the key into the release position, push the projection of the key holder into the frame of the operating mechanism and tighten it with two M6 mounting screws.
- ③ Keeping the OFF button pressed, turn the key to the lock position. Then charge the breaker, and make sure that it cannot be closed when the ON button is pushed.

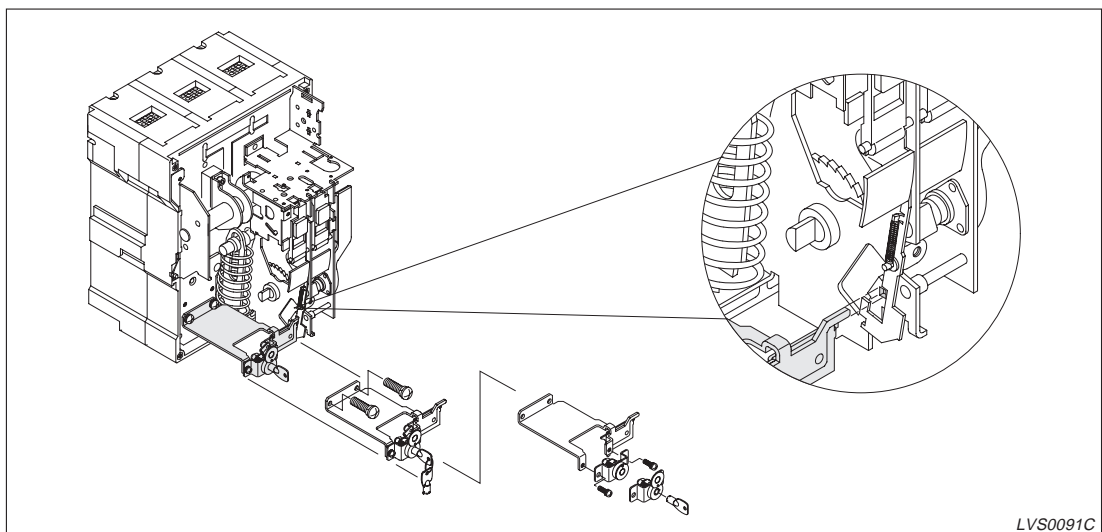

Fig. 4-27: *Installation of the cylinder lock*

LVS0091C

4.9 Castell lock (CAL)



CAUTION:

Be careful in handling the breaker inside. Do not touch the breaker mechanism as this may cause injury.

4.9.1 Removal

When the castell lock is in the release position with the OFF button pressed, remove the two M6 mounting screws which hold the key unit.

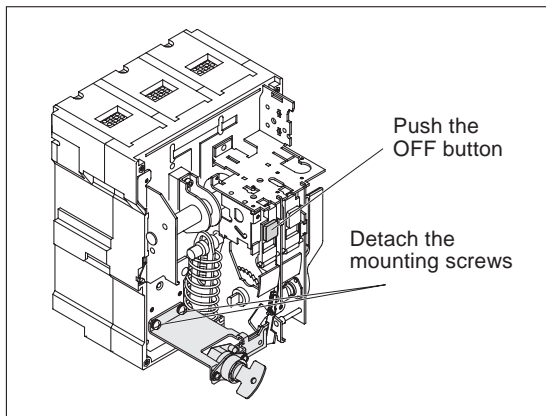
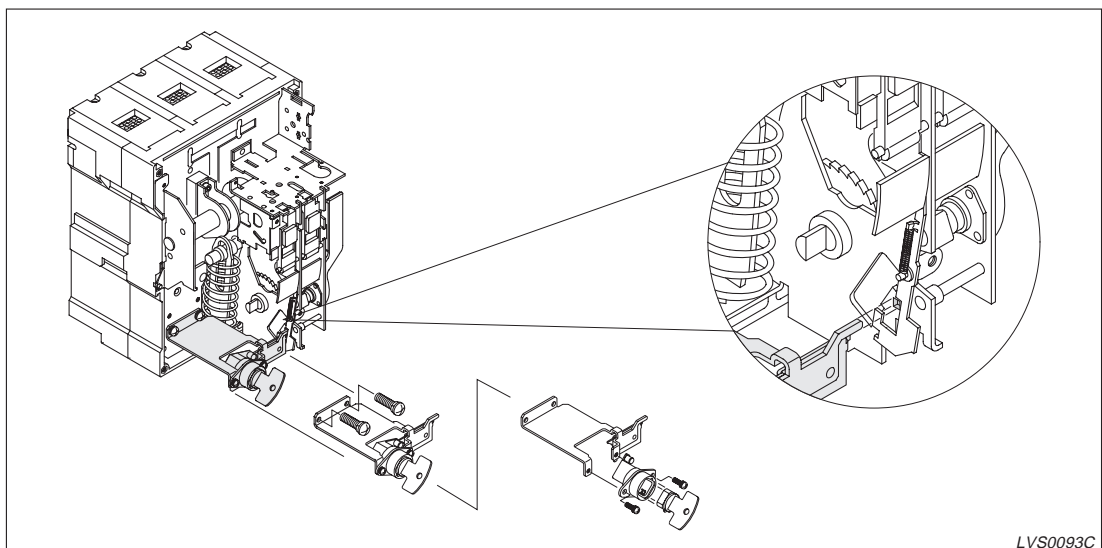

Fig. 4-28:
Removal of the castell lock

LVS0089C

4.9.2 Installation

- ① Set the breaker in the DISCHARGED and OFF position.
- ② Turn the key into the release position, push the projection of the key holder into the frame of the operating mechanism and tighten it with two M6 mounting screws.
- ③ Keeping the OFF button pressed, turn the key to the lock position. Then charge the breaker, and make sure that it cannot be closed when the ON button is pushed.



LVS0093C

Fig. 4-29: Removal of the castell lock

4.10 Counter (CNT)



CAUTION:
Be careful in handling the breaker inside. Do not touch the breaker mechanism as this may cause injury.

The counter can be mounted directly above the cylinder or castell lock.

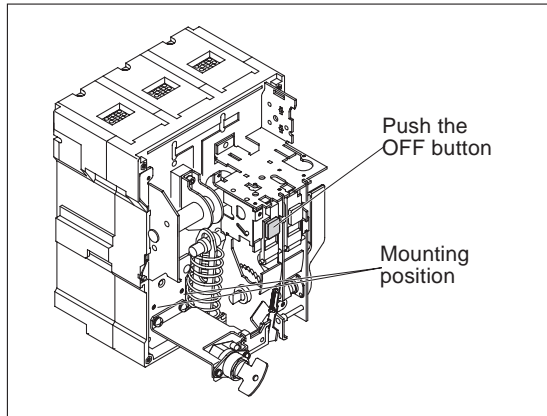

Fig. 4-30:
Preparing the breaker

LVS0099C

Fix the counter lever in the hole and secure the counter with the two fixing bolts (M5).

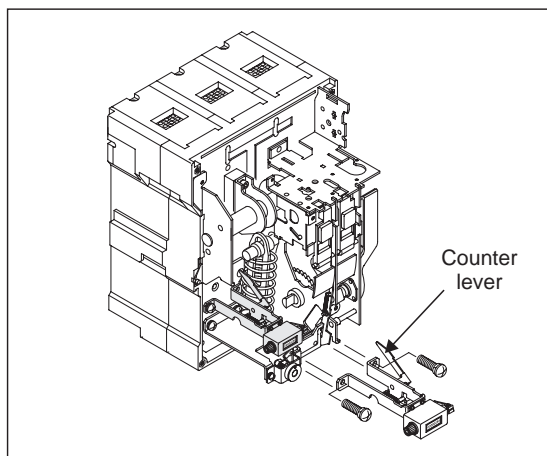

Fig. 4-31:
Mounting the counter

LVS0094C

4.11 Safety shutter (SST)

4.11.1 Operation and handling

The safety shutters are a safety device which automatically cover the main conductors (cradle side), preventing them from being touched when the breaker is drawn out. The safety shutters also allow the breaker to conform to the requirements of the class F enclosure.



DANGER:

Opening the safety shutters expose connections which may be under voltage. Do not touch these connectors otherwise an electric shock could be received resulting in severe personal injury or death.

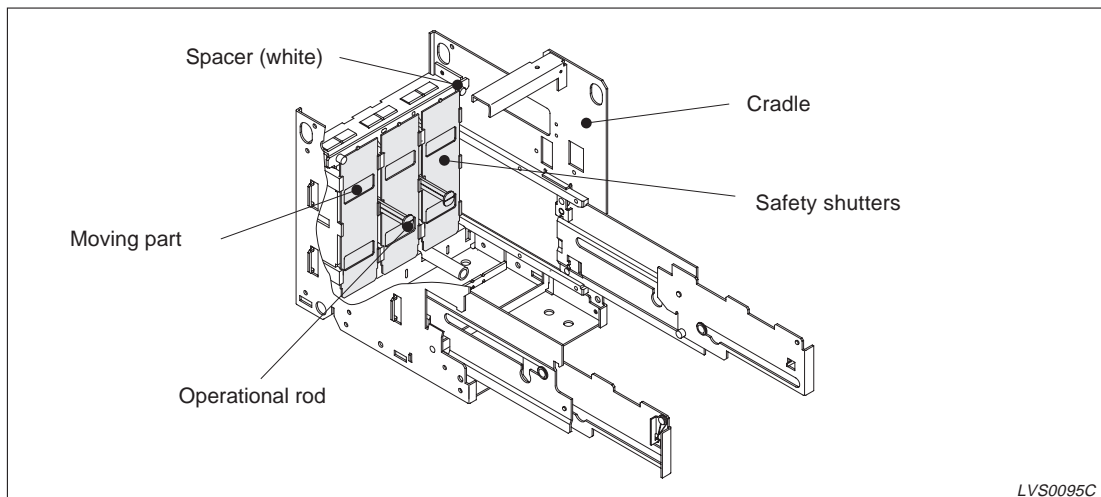

Fig. 4-32: Position of the safety shutters

When checking the main circuit, the supply side and the load side, the shutters can be individually kept OPEN (they are released automatically when the breaker is racked in).

The safety shutter of the AE-SS type breakers can keep the upper shutter and the lower shutter opened individually.

NOTE

Please place the name plates "BUSBARS" and "CABLES" on the shutter according to the actual circuits.

Handling of the shutter rods



CAUTION:

Do not push the operating rods from side to side as this will result in damaging the rods.

- ① After removing the breaker from the cradle you can find the safety shutter handle rods as shown in fig. 4-33.
- ② To close the shutter (i.e. to release the “hold” function), pull out the upper part.
- ③ To open the shutter, push at the upper part while pulling at the lower part
- ④ To keep the OPEN position, push both the left and the right operation rods in until they are stopped with a clicking sound.

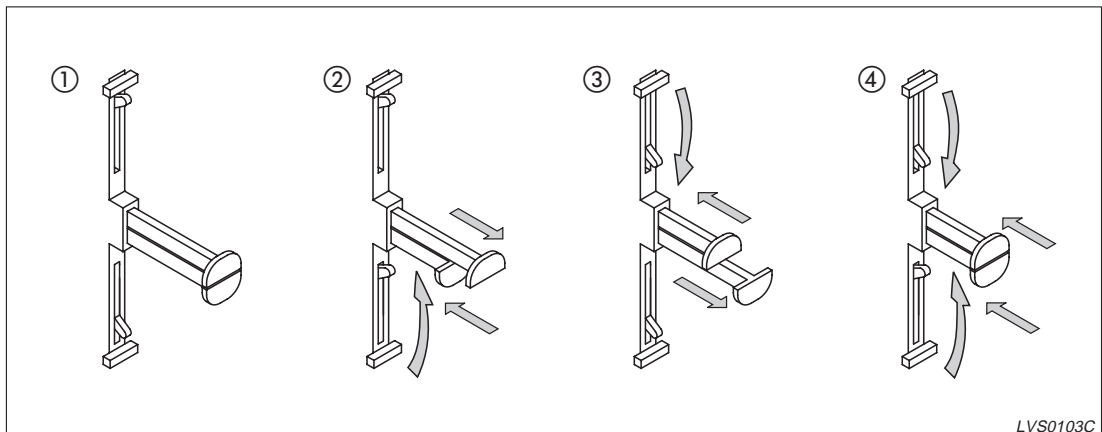

LVS0103C

Fig. 4-33: Opening and closing of the safety shutters

If the breaker is inserted in the “OPEN” state, it changes automatically to normal state.

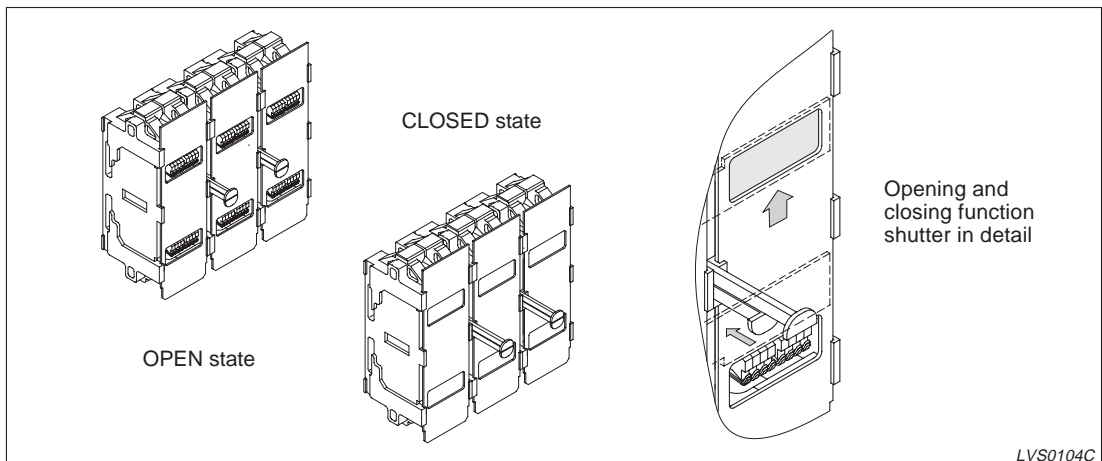

LVS0104C

Fig. 4-34: Opening and closing of the safety shutters

Safety lock kit

When the breaker has been removed from the cradle, it is possible to lock the shutters closed using a lock kit (SST-lock) and two padlocks. This prevents an accidental contact with the main conductors.

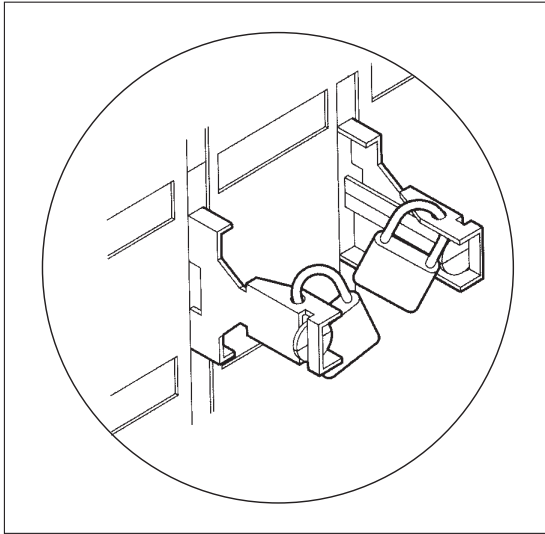

Fig. 4-35:
Padlocks

LVS0118C

NOTES

- | If this function is required, please order the lock kit (SST-lock).
- | The padlock should be provided by the customer.
- | Please put the name plates showing “BUSBARS” and “CABLES” on the shutters according to the actual circuit.

4.11.2 Installation



DANGER:

Before installing the safety shutters assure that the supply has been removed for the main circuit and from the control terminals as an electrical shock could be received resulting in severe personal injury or death.

Installation procedure for AE1000 – AE3200

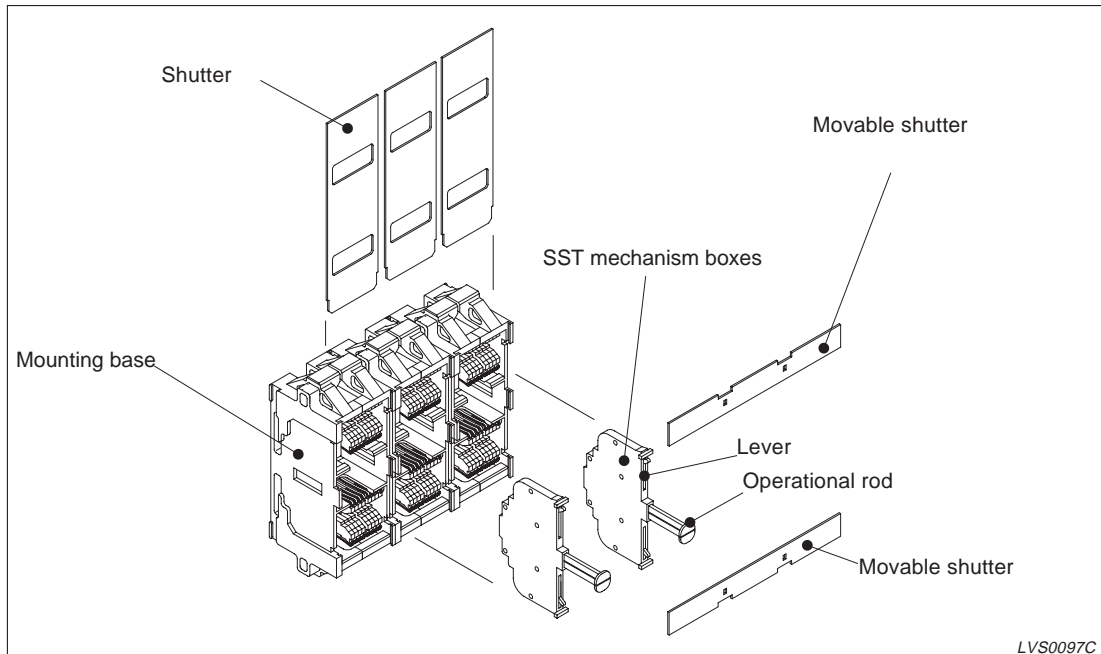

Fig. 4-36: Installation of the safety shutters

- ① Draw out the breaker from the cradle and remove it.
- ② In case of a 3-pole breaker, insert the SST mechanism boxes into the gap of the mounting bases of the cradle according to fig. 4-36.
- ③ In case of a 4-pole breaker, the SST mechanism boxes must be inserted into the gaps of the L phase and C phase, R phase and N phase.
- ④ Put the movable shutters on the lever of the safety shutters (SST) mechanism boxes.
After removing the two spacers (see fig. 4-32), insert the shutters securely into the groove of the mounting base.
- ⑤ Check the shutter operation as follows:
 - Push in both operational rods and ensure that the shutters can be opened.
 - Put in the two spacers.
 - Insert the breaker into the cradle and check the shutter operation.

Installation procedure for AE4000 – AE6300

- ① Draw out the breaker from the cradle and remove it.
- ② In case of a 3 pole breaker, insert the SST mechanism boxes into the gap of the mounting bases of the cradle according to fig. 4-37.
- ③ In case of a 4 pole breaker, the SST mechanism boxes must be inserted into the gaps of the L phase and C phase, R phase and N phase.
- ④ Put the movable shutters on the lever of the safety shutters (SST) mechanism boxes.
After removing the two spacers, insert the shutters securely into the grooves of the mounting base. Please check the correct insertion because the shape of center-pole shutter is different from others.
- ⑤ Hook the shutter springs between the movable shutter and the upper angle of the drawout frame at each side (see circle in fig. 4-37).

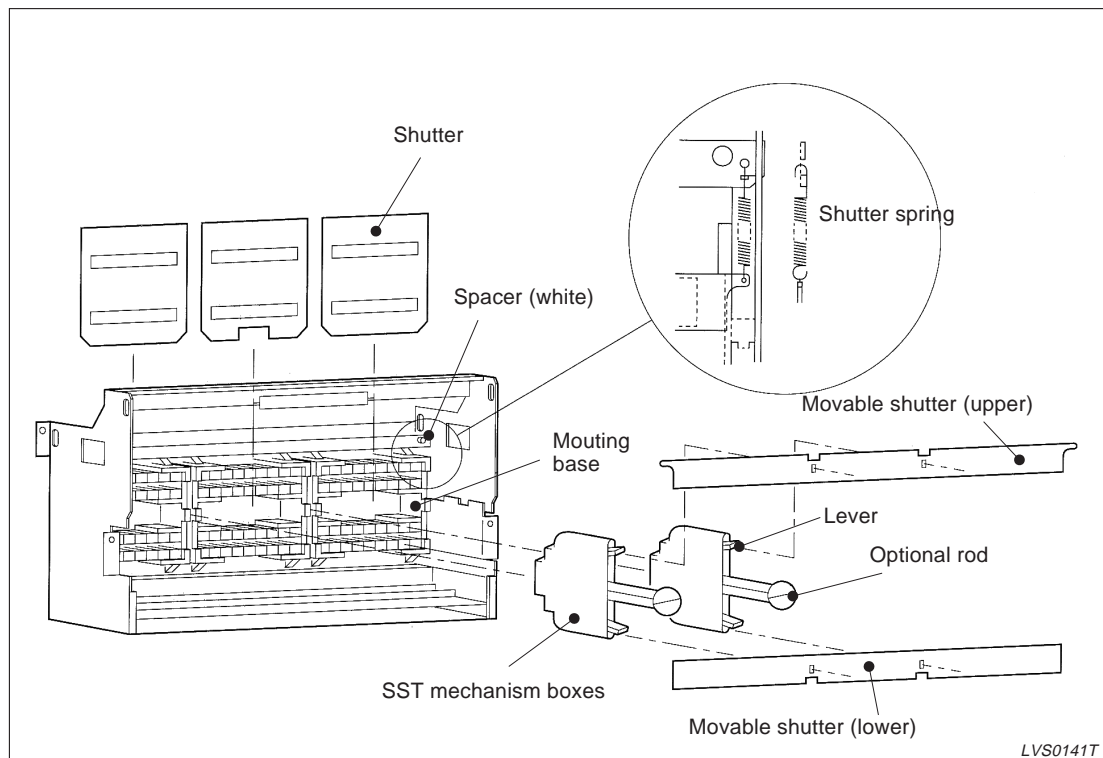

Fig. 4-37: Installation of the shutter spring

4.12 Shorting b-contact (SBC)

This contact, when installed in the control circuit terminal block, short circuits the auxiliary switch (NC) from the test position, thus maintaining the correct sequence of operation of the external control circuits when the breaker is drawn from the connected to the test position. When ordering the shorting b-contacts (SBC) the same number of SBC can be provided as the number of auxiliary switches (NC) that are being provided.

4.12.1 Removal



DANGER:

Before commencing work at the contacts make shure that the control supply is shut off and the control power cables are removed as this will cause an electric shock.

- ① If your breaker is a drawout type, draw out the breaker unit from the cradle.

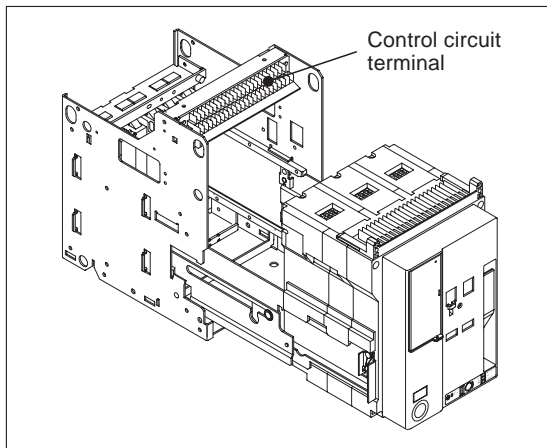

Fig. 4-38:

Separation of the breaker unit from the cradle

LVS0083C

- ② Cut off the power of the control source, if necessary and take away all plugs and cables from the terminal.
- ③ Loosen the two fixing bolts of the terminal strip.

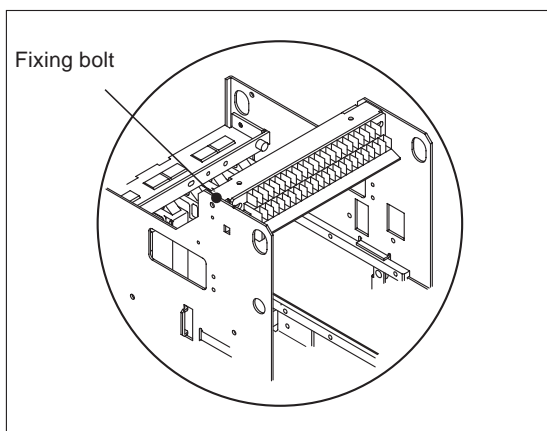

Fig. 4-39:

Removal of the fixing bolts

LVS0088C

- ④ Detach the terminal strip as shown in the following figure.

- ⑤ Disassemble the safety cover from the terminal strip.

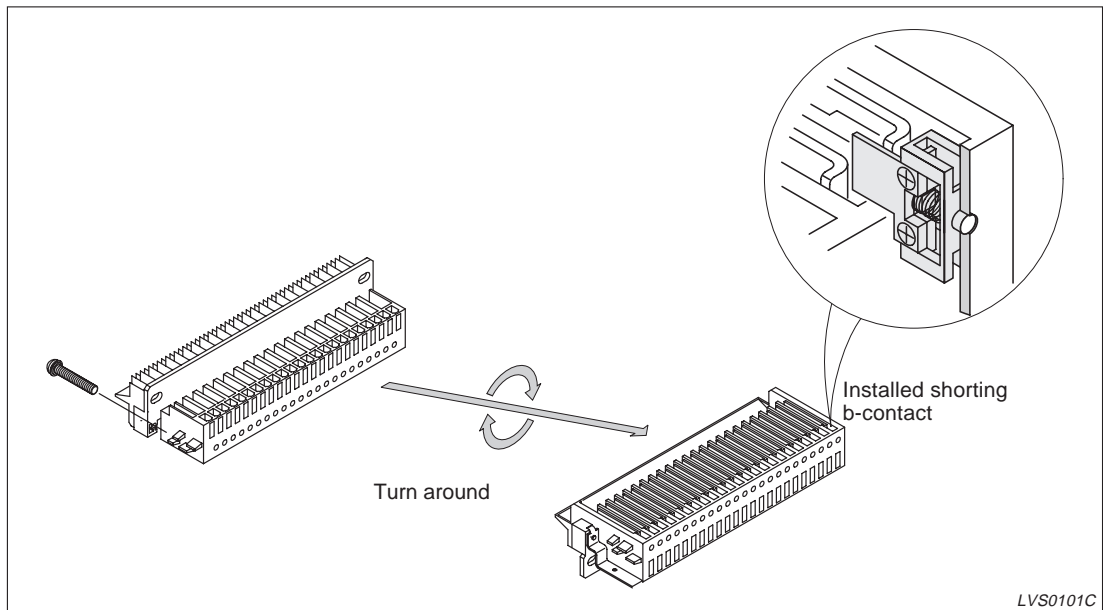

Fig. 4-40: Preparation of the strip

- ⑥ Insert the small cross screwdriver into the hole of the control circuit terminal. Then, lightly turn the screwdriver to the upside as shown in fig. 4-41. The SBC can then be removed.

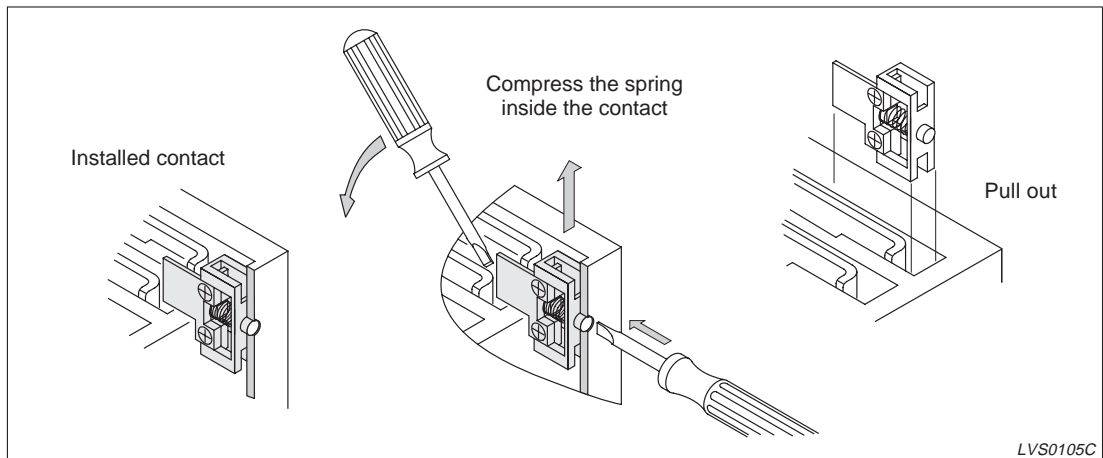

Fig. 4-41: Removal of the shorting b-contact from the strip

4.12.2 Installation

- ① Keeping the shorting b-contact (SBC) compressed, insert the device into the correct position of the control circuit terminal normal close and put the projection of the shorting b-contact (SBC) into the hole of the control circuit terminal.
- ② Keeping the shorting b-contact (SBC) compressed, push it into the control circuit terminal.

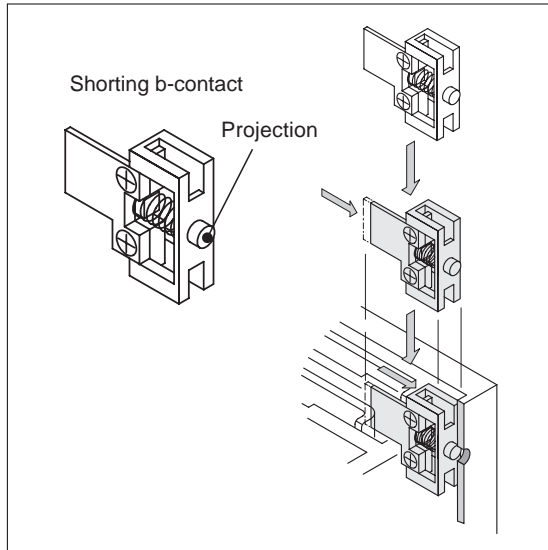

Fig. 4-42:
Installation of the shorting b-contact

LVS0107C

- ③ Check if the shorting b-contact is inserted correctly in the terminal strip.

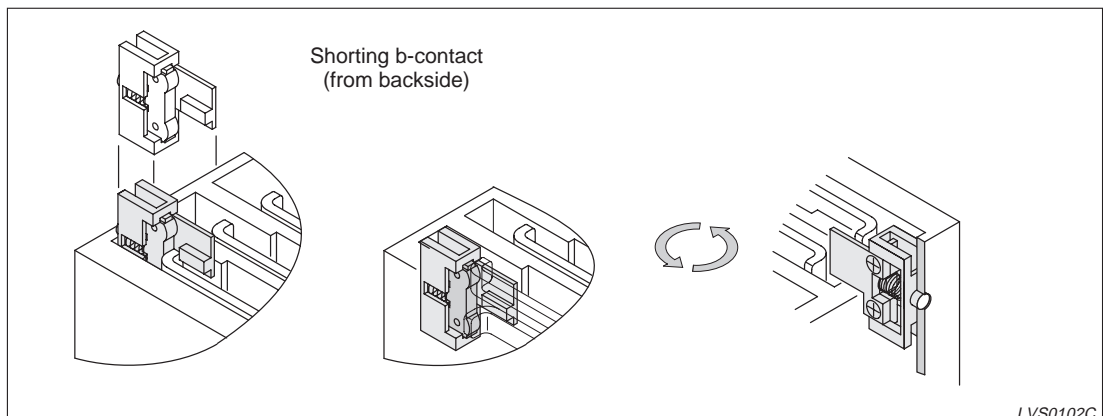

Fig. 4-43: Removal of the shorting b-contact

LVS0102C

- ④ After the shorting b-contact has been installed, verify that the SBC can be operated smoothly. Confirm AXb contact is shorted when ACB is drawn out and confirm AXb contact is opened when ACB is inserted and on.

4.13 Mis-insertion preventor (MIP)

This device prevents any other circuit breaker except those specified by the user's setting from being inserted into the cradle. 5 kinds of settings are available.

| Applied breaker | AE-SS/SH type |
|---------------------|---------------|
| Mis-insertion plate | 1 |
| Mis-insertion chips | 5 |

Tab. 4-2:
Parts component (1 set)

NOTE

For AE4000-SS to AE6300-SS the mis-insertion preventor is not available.

4.13.1 Preparation

- ① Draw out the breaker from the cradle and take it out. (Refer to para. 2-11.)

Cradle side

- ② Insert the mis-insertion plate into the specified hole of the rear mounting angle of the cradle according to figures 4-44 and 4-45 and the installing point table 4-3.

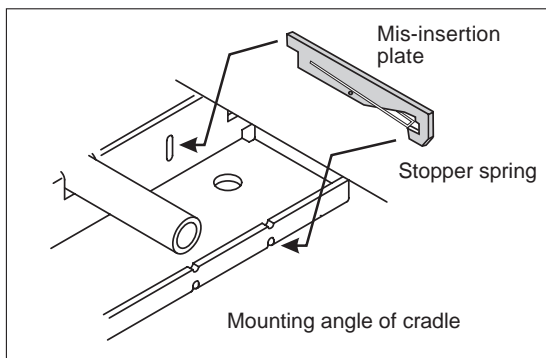
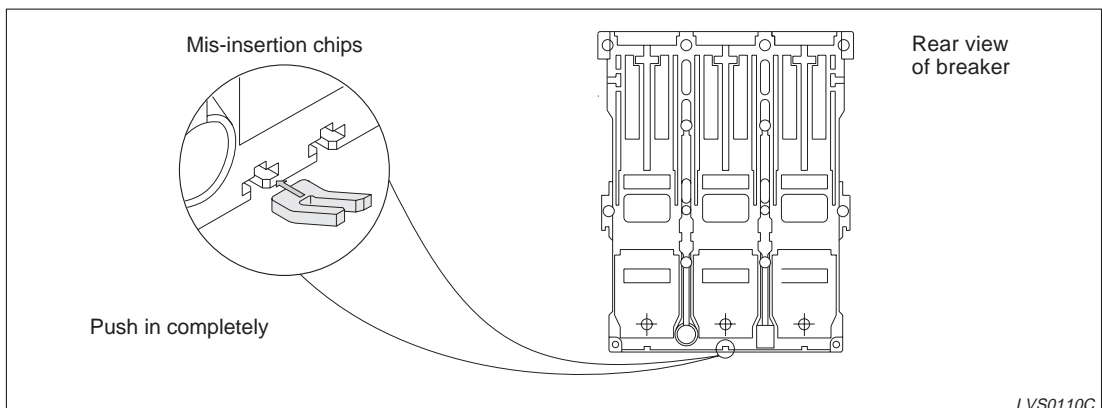

Fig. 4-44:
Insertion of the mis-insertion plate (cradle side)

LVS0108C

Breaker side

- ③ Push the mis-insertion chips into the specified grooves at the bottom of the breaker as shown in the figure below and in the installing table.



LVS0110C

Fig. 4-45: Insertion of the mis-insertion chips (breaker side)

4.13.2 Installing points

The following figure in combination with table 4-3 shows the possible installation points of the mis-insertion preventers.

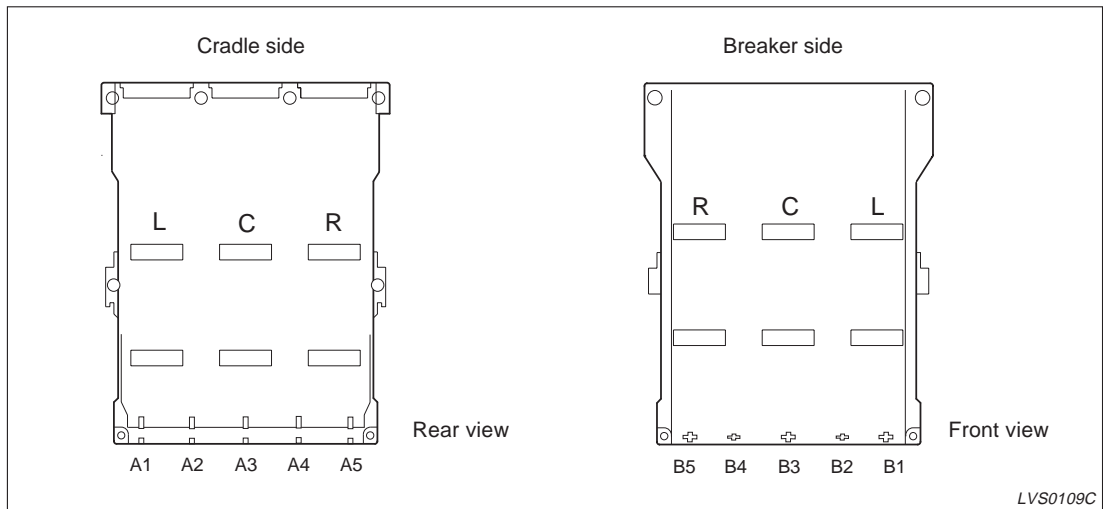

Fig. 4-46: Installing points at the cradle side and the breaker side

| In case of 2 breakers | Cradle side | | | | | Breaker side | | | | |
|-----------------------|-------------|----|----|----|----|--------------|----|----|----|----|
| | A1 | A2 | A3 | A4 | A5 | B1 | B2 | B3 | B4 | B5 |
| No. 1 breaker | ○ | | | | | | | | | ○ |
| No. 2 breaker | | | | | ○ | ○ | | | | |
| In case of 3 breakers | Cradle side | | | | | Breaker side | | | | |
| | A1 | A2 | A3 | A4 | A5 | B1 | B2 | B3 | B4 | B5 |
| No. 1 breaker | ○ | | | | | | | ○ | | ○ |
| No. 2 breaker | | | ○ | | | ○ | | | | ○ |
| No. 3 breaker | | | | | ○ | ○ | | ○ | | |
| In case of 4 breakers | Cradle side | | | | | Breaker side | | | | |
| | A1 | A2 | A3 | A4 | A5 | B1 | B2 | B3 | B4 | B5 |
| No. 1 breaker | ○ | | | | | | ○ | | ○ | ○ |
| No. 2 breaker | | ○ | | | | ○ | | | ○ | ○ |
| No. 3 breaker | | | | ○ | | ○ | ○ | | | ○ |
| No. 4 breaker | | | | | ○ | ○ | ○ | | ○ | |
| In case of 5 breakers | Cradle side | | | | | Breaker side | | | | |
| | A1 | A2 | A3 | A4 | A5 | B1 | B2 | B3 | B4 | B5 |
| No. 1 breaker | ○ | | | | | | ○ | ○ | ○ | ○ |
| No. 2 breaker | | ○ | | | | ○ | | ○ | ○ | ○ |
| No. 3 breaker | | | ○ | | | ○ | ○ | | ○ | ○ |
| No. 4 breaker | | | | ○ | | ○ | ○ | ○ | | ○ |
| No. 5 breaker | | | | | ○ | ○ | ○ | ○ | ○ | |

Tab. 4-3: Installing points

4.14 Mechanical interlock (MI)

The mechanical interlock is a secure interlock preventing the parallel closing of two or three breakers.

- ① Any combination between AE1000-SS to AE3200-SS, AE1000-SH to AE3200-SH, and AE4000-SSC is possible.
- ② It can be easily installed on both fixed and drawout type breakers.
- ③ For the drawout type, the interlock only operates in the connected position and is released in the other positions. This allows an easy and safe maintenance and inspection of the breakers.

NOTE

A breaker not specified as “to be equipped with a mechanical interlock” does not accept a mechanical interlock.

A dimensional drawing for the installation of the mechanical interlock is shown in fig. 4-47.

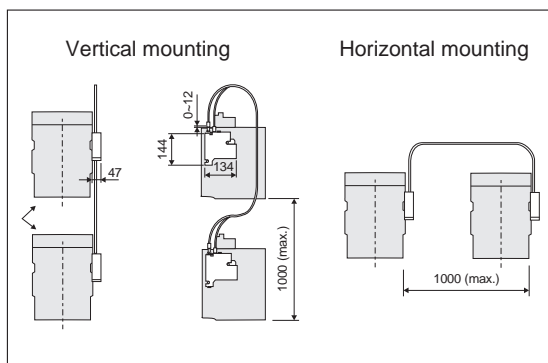

Fig. 4-47:
Dimensional drawing for the installation of the mechanical interlock

LVS0112C

NOTE

Please apply for further details, if “changeover of 2 power supplies” is required.

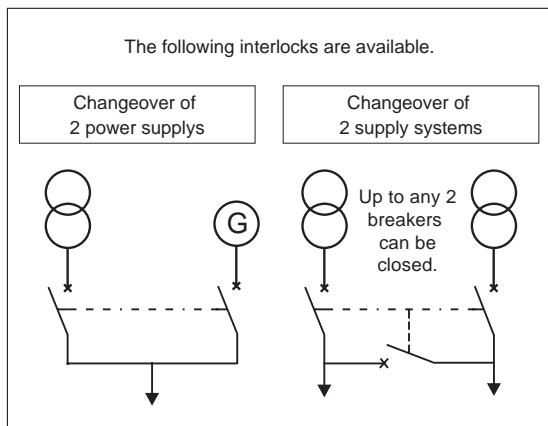

Fig. 4-48:
Changeover of 2 power supplies

LVS0111C

4.14.1 Preparation

Changeover of 2 power supplies

- ① The MI units are mounted on the cradle or frames after wiring between 2 units.
- ② Connect the interlock wires (see fig. 4-53).
- ③ When there is a partition between the breakers, put the wires through the partition hole. Then connect the interlock wires to the MI units.
- ④ Put the end of the interlock wire from the adjuster into the wire support (T) which is in the other MI unit (refer to fig. 4-49). Loosen the adjuster nut and turn the adjuster counterclockwise to securely attach the end of the interlock wire (refer to the following figure).

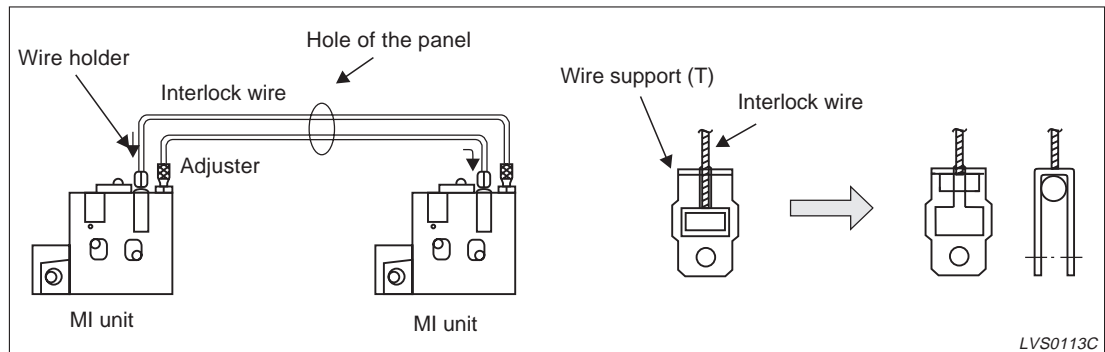

Fig. 4-49: MI unit mounting - changeover of 2 power supplies

- ⑤ Tighten the wire holder (tightening torque: 24 – 31 kg/cm). Connect the 2 wires to each other (refer to fig. 4-50).

(Actually, this installation is done in a panel builder.)

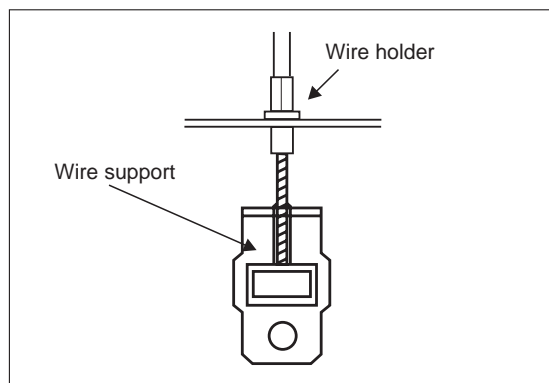

Fig. 4-50: Mounting the door lock unit

LVS0114C

4.14.2 MI unit mounting on the breaker



CAUTION:

Before mounting turn both breakers OFF. Check by the indicators whether the air circuit breakers are really in the “OFF” and “DISCHARGED” position.

In case of drawout-type air circuit breakers, remove the breakers from the cradle.

Drawout type breaker

Install the drawout frame in the panel. After connecting the interlock wires, mount the MI unit onto the drawout frame by tightening the M5 bolts and spring washers (the tightening torque is 2.9–3.8 Nm).

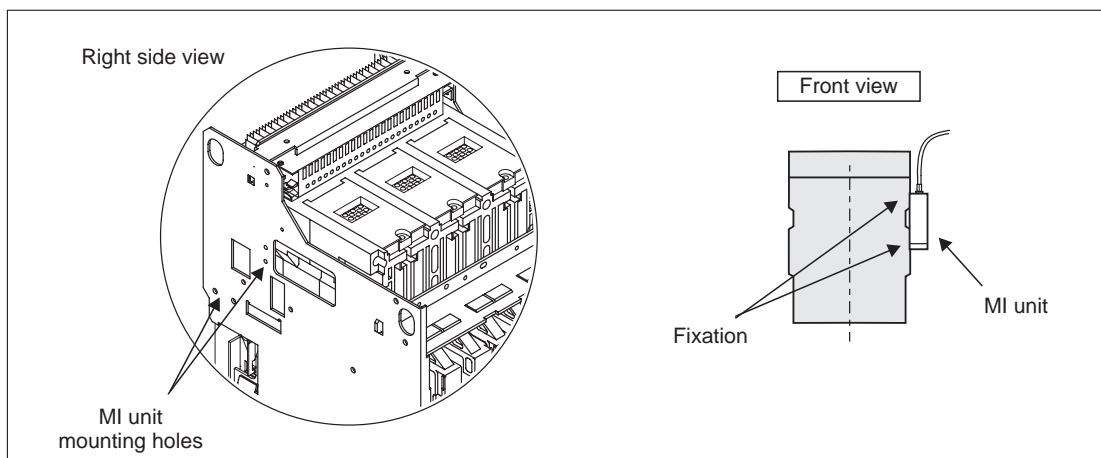

Fig. 4-51: MI unit mounting on the breaker (drawout type)

Fixed type breaker

- ① Remove the hexagonal screws on the the right side frame (refer to fig. 4-52).
- ② Mount the MI unit on the right side frame by tightening the M6 bolts and spring washers (tightening torque: 2.9–3.8 Nm).

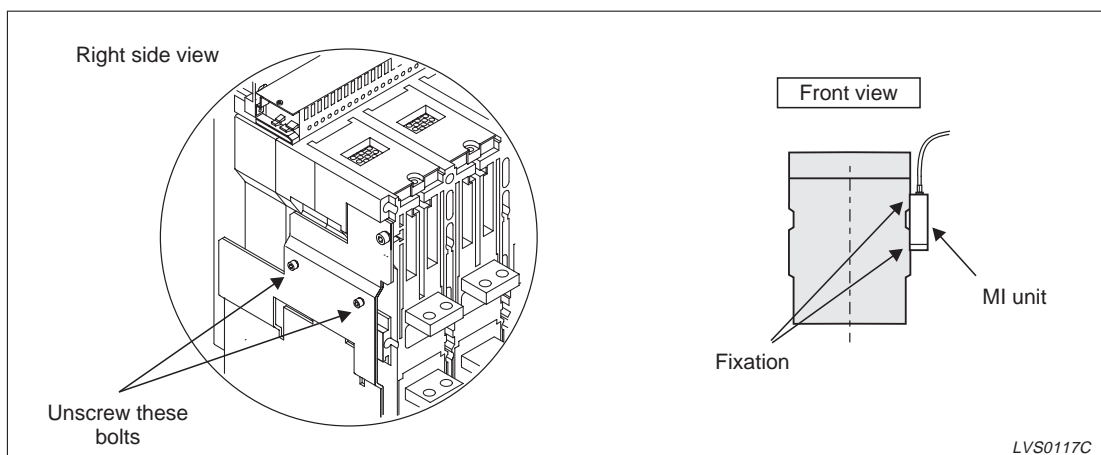

Fig. 4-52: MI unit mounting on the breaker (fixed type)

LVS0117C

4.14.3 Adjustment

- ① Insert the breaker (in case of the drawout type).
- ② Fix the interlock wires by applying wire sticker.



CAUTION:
 Mount the interlock wires correctly. Otherwise there is the possibility of problems with the wire motion. Make shure to adjust the gap between the lever (trip shaft) and the trip pin otherwise problems may occur with the motion of interlock.

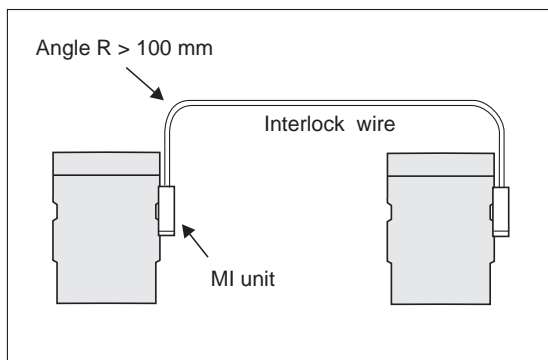
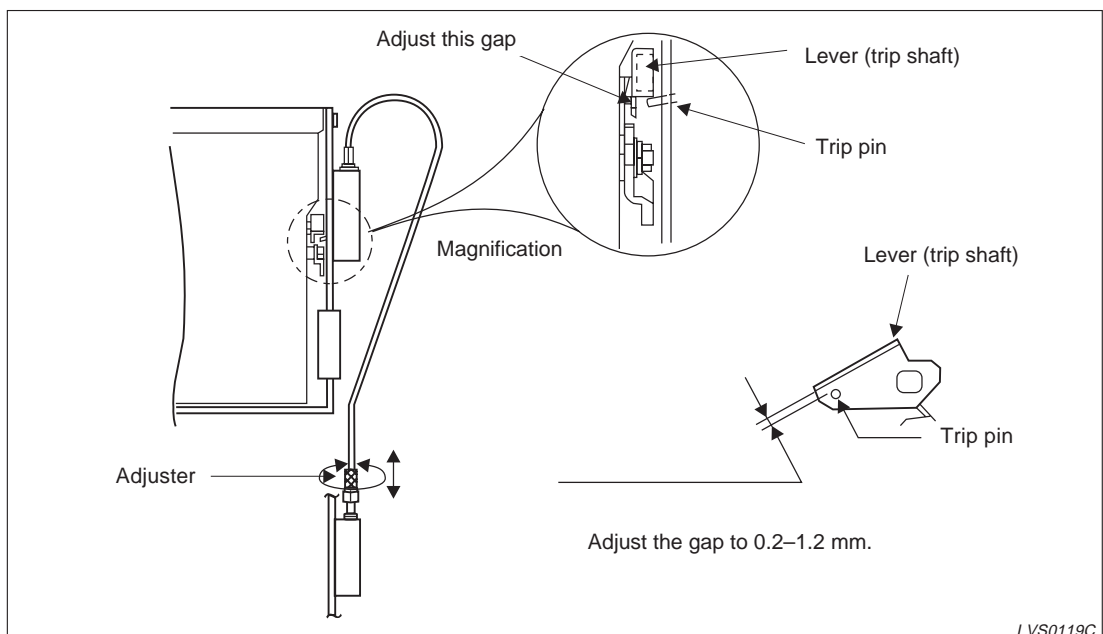

Fig. 4-53:
 Fixing of the interlock wires

LVS0115C

- ③ Adjust the gap between the trip pin of the MI unit and the lever (trip shaft) (refer to fig. 4-54).

The gap can be adjusted by turning the adjuster of the other MI unit. Turn the adjuster counterclockwise. Check whether the gap has become zero. Then turn the adjuster clockwise to adjust the gap to 0.2–1.2 mm.



LVS0119C

Fig. 4-54: Adjustment of the gap between MI unit and lever (detail)

- ④ After adjusting, fix the adjuster by tightening the nut.

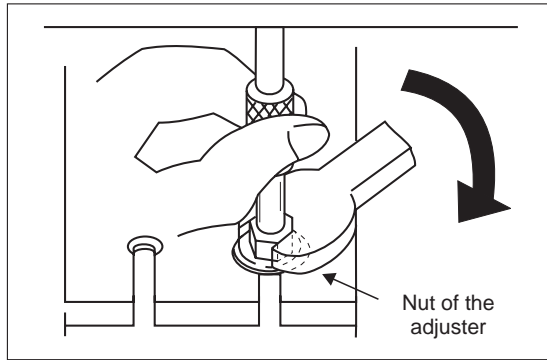

Fig. 4-55:
Fixing the adjuster

LVS0121C

4.14.4 Operation check between 2 breakers

- ① Turn off both breakers.
- ② Charge both breakers.
- ③ Turn on breaker no. 1.
- ④ Try to turn on breaker No. 2 by pushing the ON button. Confirm that breaker no. 2 cannot be turned on.
- ⑤ Turn off both breakers.
- ⑥ Charge both breakers
- ⑦ Turn on breaker no. 2.
- ⑧ Try to turn on breaker no. 1 by pushing the ON button. Confirm that breaker no. 1 cannot be turned on.
- ⑨ After several operation checks, confirm that the gap between the trip pin and the lever (trip shaft) is still 0.2 – 1.2 mm. If not so, adjust the gap according to the description on the previous page.

4.14.5 Maintenance

When maintaining the breaker, confirm that the gap between the trip pin and the lever (trip shaft) is 0.2–1.2 mm (refer to fig. 4-54). If not so, re-adjust the gap.

NOTES

The mechanical interlock is only operative when the breakers are connected.

After turning off one breaker, do not turn on the other breaker unless at least 0.5 sec. have elapsed.

The mechanical interlock is a safety interlocking accessory that prevents a parallel turning on of two breakers.

If two breakers are turned on at the same time, both breaker main contacts may turn on momentarily. Therefore, breakers should never be turned on simultaneously.

4.15 Door interlock (DI)

The door interlock is a safety device that allows the panel door to open only when the breaker is turned OFF. This interlock system features an interlock wire which interlocks the DI unit on the breaker's side with the door lock unit. Thus, the breaker can be installed in any position within a specified area. Follow the instructions given below when installing this device.

4.15.1 DI unit mounting (installation of DI unit)

**CAUTION:**

Before mounting turn the breaker OFF. Check by the indicator whether the air circuit breaker is in the "OFF" and "DISCHARGED" position.

In case of drawout-type air circuit breakers, remove the breakers from the cradle.

Drawout type breaker

Install the drawout frame in the panel. After connecting the interlock wires, mount the DI unit onto the drawout frame by tightening the M5 bolts and spring washers (the tightening torque is 2.9–3.8 Nm).

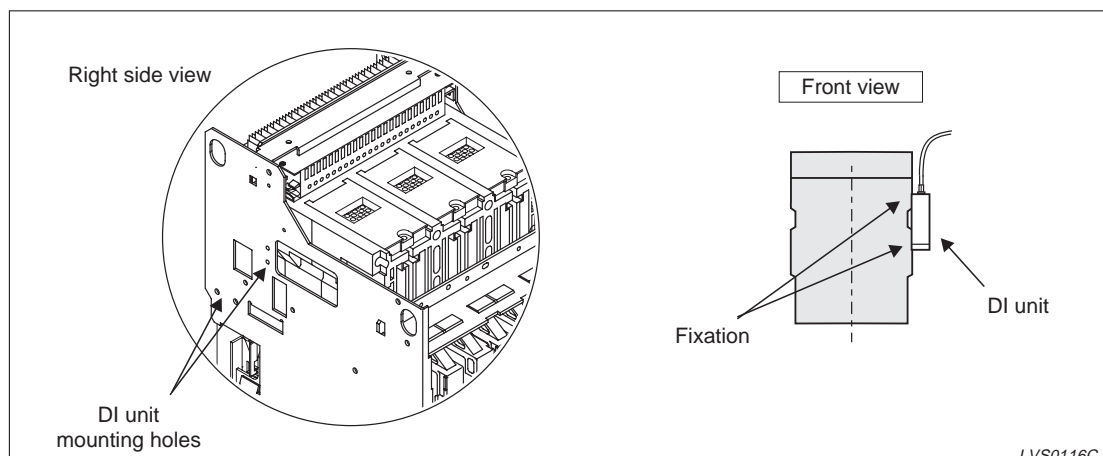

Fig. 4-56: DI unit mounting on the breaker (drawout type)

Fixed type breaker

- ① Remove the hexagonal screws on the the right side frame (refer to fig. 4-57).
- ② Mount the DI unit on the right side frame by tightening the M6 bolts and spring washers (tightening torque: 2.9–3.8 Nm).

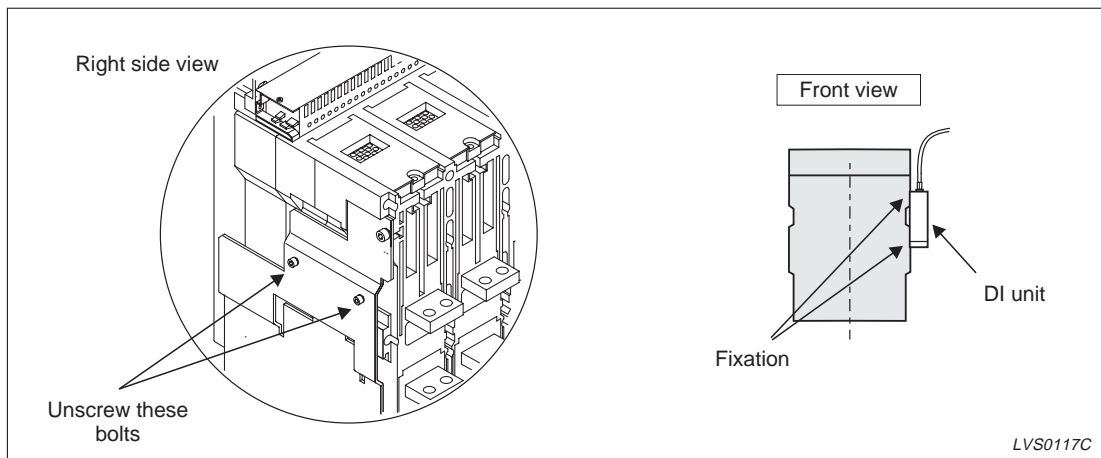

Fig. 4-57: DI unit mounting on the breaker (fixed type)

4.15.2 Door lock unit mounting

- ① Mount the door lock unit at a suitable place for door locking in the panel by using 2 M5 x 14 screws (refer to fig. 4-58 as an example).

NOTE

As the door hook is not included in this accessory, it has to be provided by the customer.

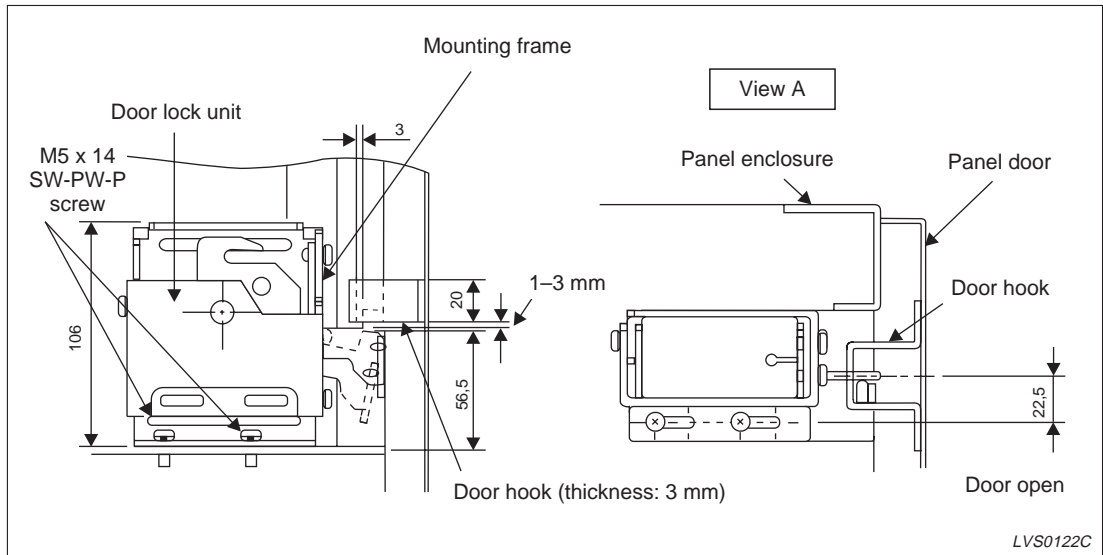

Fig. 4-58: Example for mounting the door lock

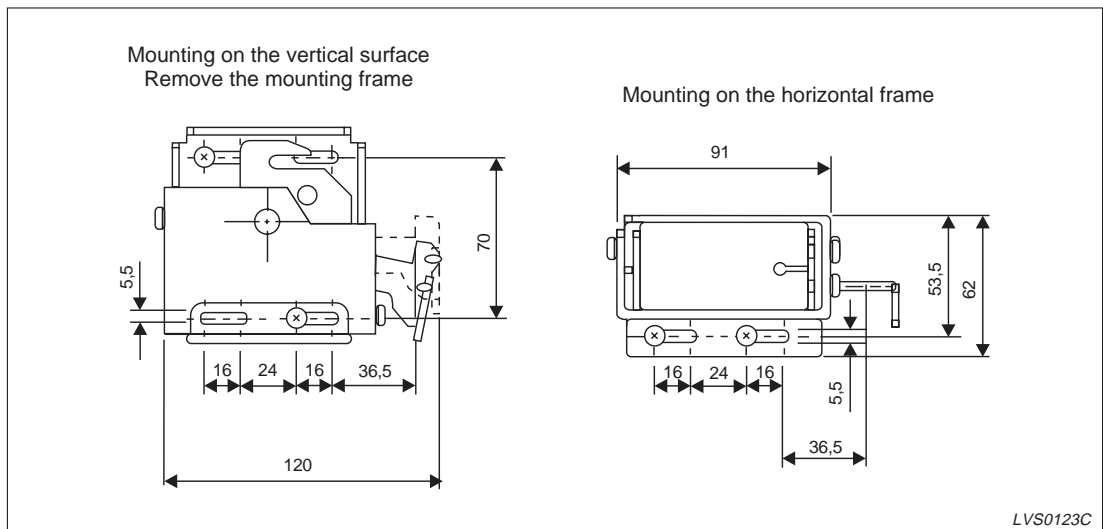

Fig. 4-59: Dimensions for unit mounting on the surface (in mm)

- ② Put the end of the interlock wire from the adjuster into the wire support which is situated in the door lock unit.

As the door lock unit has 2 wire supports, any connection (vertical or horizontal) can be chosen (see fig. 4-60).

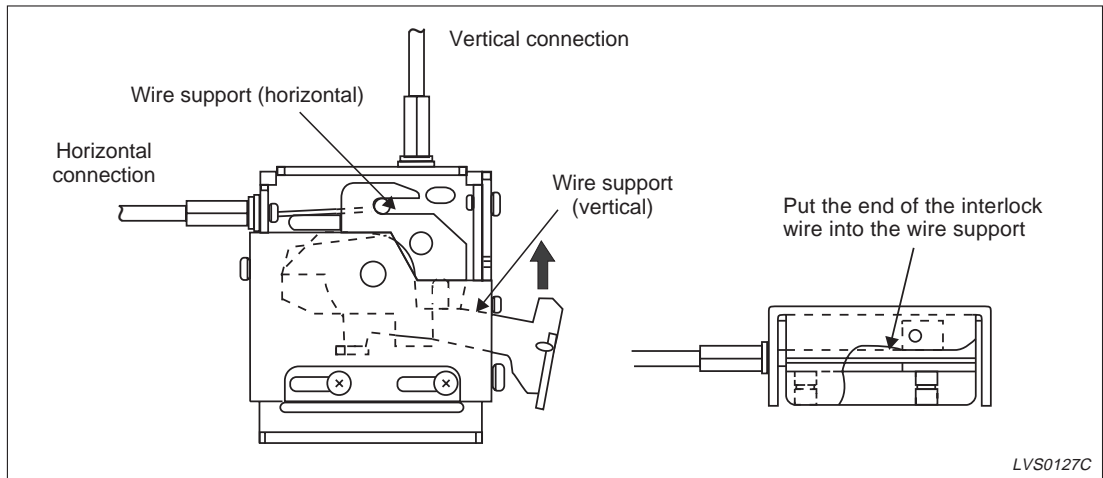

Fig. 4-60: Installation of the interlock wire

- ③ Loosen the adjuster nut and turn the adjuster counterclockwise to securely attach the end of the interlock wire.
- ④ Tighten the wire holder (tightening torque: 2.4 – 3.1 Nm; refer to fig. 4-61).

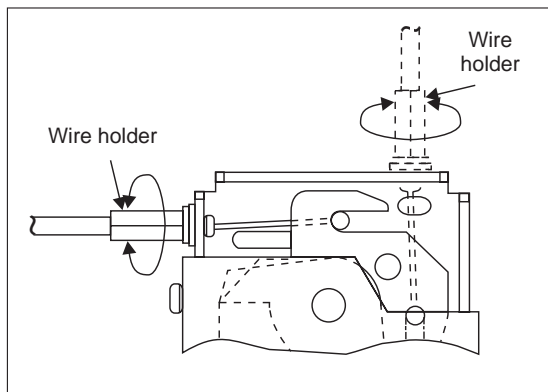

Fig. 4-61: Tightening of the wire holder

4.15.3 Releasing the door interlock

The door interlock can be released manually while the breaker is in the ON position. If this function is needed, it is necessary to open a hole of a minimum diameter of 7 mm in the door. Further details and the drilling plan is shown in the following figure.

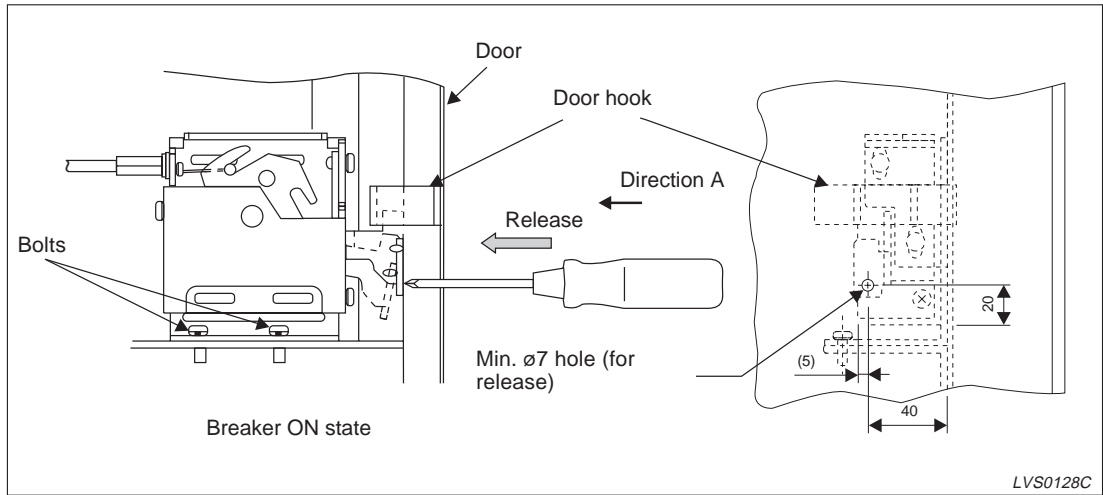

Fig. 4-62: Installation of the interlock wire

4.15.4 Adjustment

- ① Fix the interlock wires (see fig. 4-63).

NOTE

| The maximum bending radius is 100 mm.

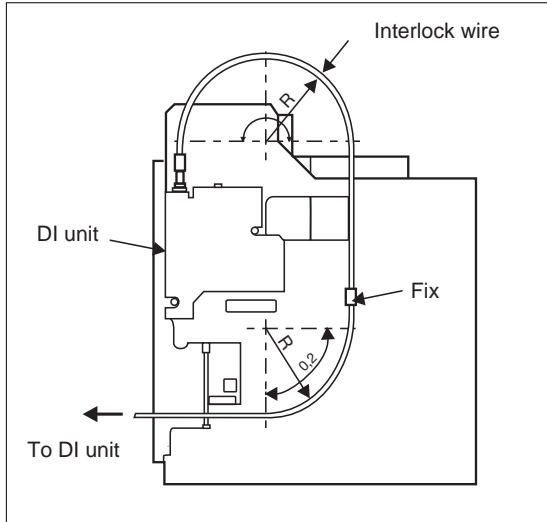

Fig. 4-63:
Fixing the interlock wires

LVS0132C

- ② Pull at the cover of the interlock wire. Turn the adjuster counterclockwise until the arm of the door lock unit starts to move.

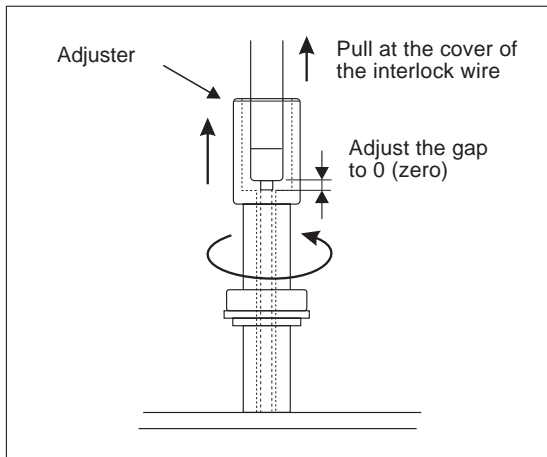

Fig. 4-64:
Adjusting

LVS0136C

- ③ The gap between the adjuster and the cover of the wire must be 0 (zero). If not so, adjust the gap to 0 (zero) by turning the adjuster (see fig. 4-65). The adjusting point is a point which starts to move by turning the adjuster.

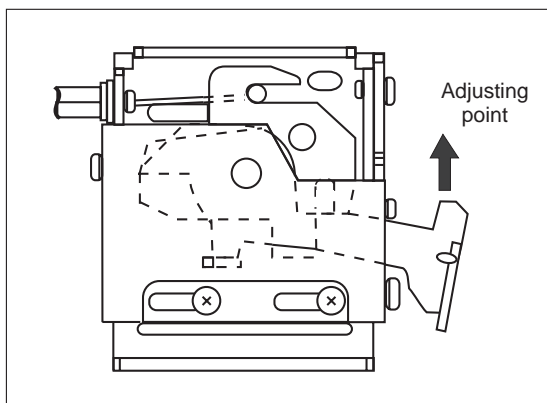

Fig. 4-65:
Adjusting point

LVS0134C

- ④ After adjusting, fix the adjuster by tightening the nut.

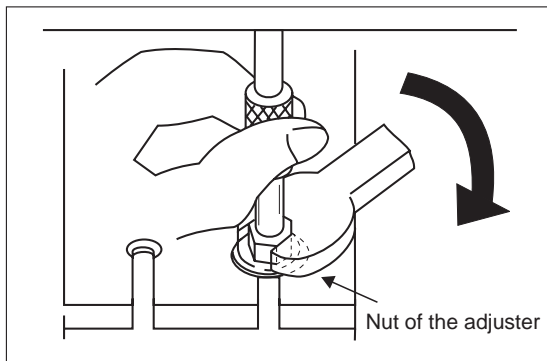

Fig. 4-66:
Fixing the adjuster

LVS0121C

4.15.5 Operation check

- ① Turn the breaker several times ON and OFF. Make sure that the lock unit operates satisfactorily.
- ② The door of the panel cannot be opened as long as the breaker is turned ON.
The door can be opened when the breaker is turned OFF:

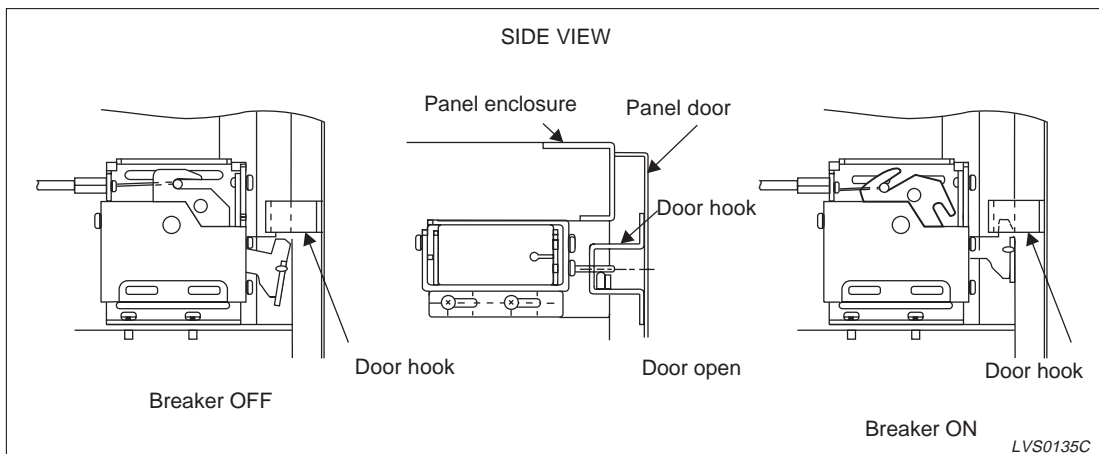

Fig. 4-67: Operation check

LVS0135C

4.16 Test jumper (TJ)

When the breaker is removed from the cradle, the breaker can be operated electrically and the wiring scheme can be checked.

- Attach the test jumper for electrical operation only after the breaker has been removed from the cradle.
- The length of the test jumper is 3 m (without any requests).



CAUTION:

Turn the control supply OFF before installing the test jumper and take extra care as the main supply may be "ON" to avoid the risk of an electric shock.

Supply the control voltage after having attached the test jumper to both the breaker and the cradle.

4.16.1 Inserting and removing the test jumper on the breaker

Inserting

- ① Turn the lock lever in the direction to outside the test jumper (see arrows in fig. 4-68). Insert the test jumper horizontally.
- ② After inserting the test jumper, turn the lock lever towards the direction of the breaker in order to prevent it from removing (see fig. 4-68).

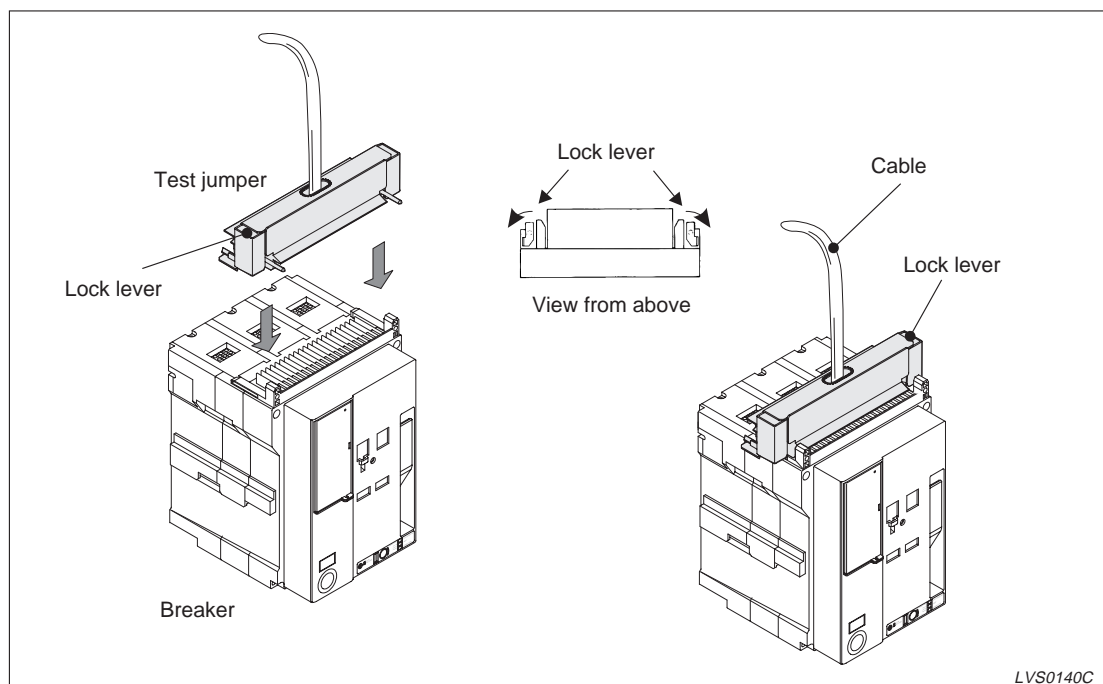

Fig. 4-68: Operation check

Removing

Turn the lock lever in the opposite direction (see arrows in fig. 4-69) and remove the test jumper from the breaker.

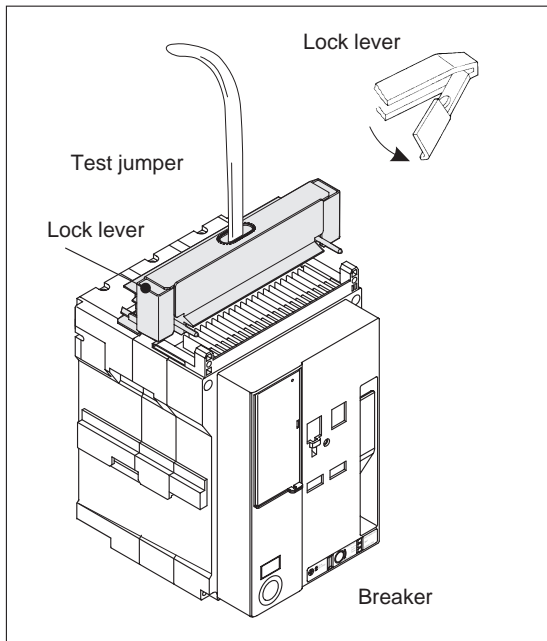

Fig. 4-69:
Removing the test jumper

LVS0141C

4.16.2 Inserting and removing the test jumper on the cradle

Inserting

Insert the test jumper into the cradle until it is stopped.

Push the test jumper to the bottom of the control terminal block while lifting the test jumper.

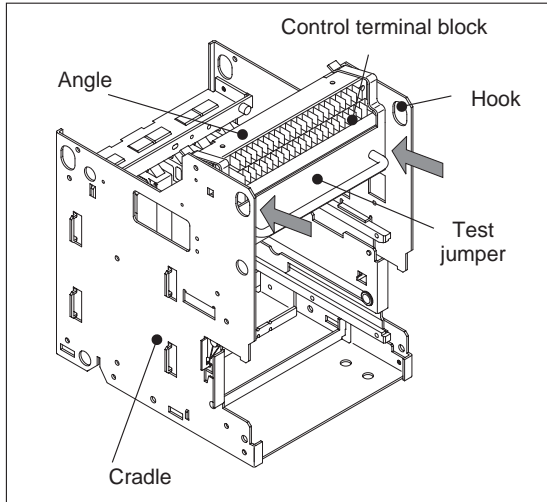

Fig. 4-70:
Inserting the test jumper

LVS0143C

NOTE

Be careful not to damage the wirings while inserting the test jumper.

Removing

Pull slowly at the handle of the test jumper (see fig. 4-71).

Do not slant the test jumper while removing it.

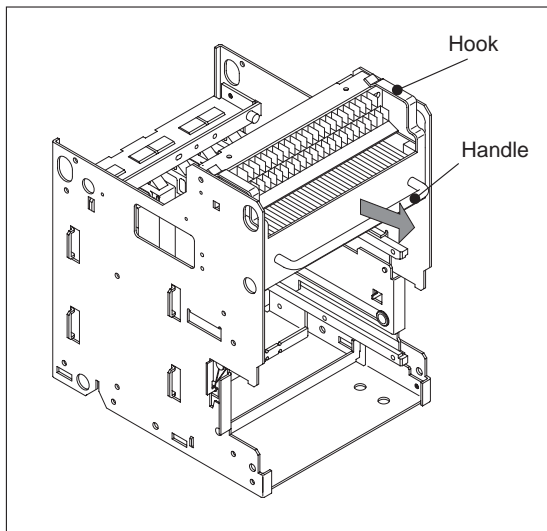

Fig. 4-71:
Removing the test jumper

LVS0142V

4.17 External ZCT for load circuits

The SPET and SPETC electronic trip relays of the Super AE series can protect against earth leakage (ER) if these relays are combined with an external ZCT. Specify the following and connect them according to the instructions below.

- Electronic trip relay: SPET or SPETC type.
- External ZCT: External ZCT for the load circuits (ZCT163 to ZCT324) or external ZCT for transformer ground wire (ZT15A to ZT100A). These are provided with a 2-core shield wire (2 m).
- SHT: When the breaker is required to trip on earth leakage it should be fitted with a shunt trip. Shunt trips are available to suit AC/DC 100/250 V or DC 24/48 V supplies. Please specify.

4.17.1 Precautions when installing the external ZCT for load circuits

- ① Application of ZCT
 - ZCT163 ... AE1000-SS to AE1600-SS 3P
 - ZCT323 ... AE1000-SS/SH to AE1600-SS/SH 3P/4P
AE2000-SS/SH to AE3200-SS/Sh 3P
 - ZCT324 ... AE1000-SS/SH to AE3200-SS/SH 3P/4P
- ② Allow for a 5 mm or more clearance between the primary conductors and the bore of the ZCT and firmly brace the primary conductors so as not to leave the ZCT subject to the electro-magnetic force on the primary conductors resulting from the high current flowing. For bare conductors be sure to allow for a sufficient insulation gap between them and the mounting plate.
- ③ Primary conductors should be arranged symmetrically in both vertical and horizontal planes and on maximum pitch between primary conductors should be as follows:
 - ZCT163 ... 85 mm
 - ZCT323 ... 130 mm
 - ZCT324 ... 130 mm
- ④ All other large current circuits should be installed at least 200 mm away from the ZCT.
- ⑤ The ZCT fixing plate should be earthed.
- ⑥ The wiring distance between the ZCT and the breaker should be 3 m or less. The wire should be shielded wire and routed away from the power lines as far as possible (the ZCT is provided with 2 m of shielded wire).
- ⑦ Do not earth the secondary side of the ZCT.

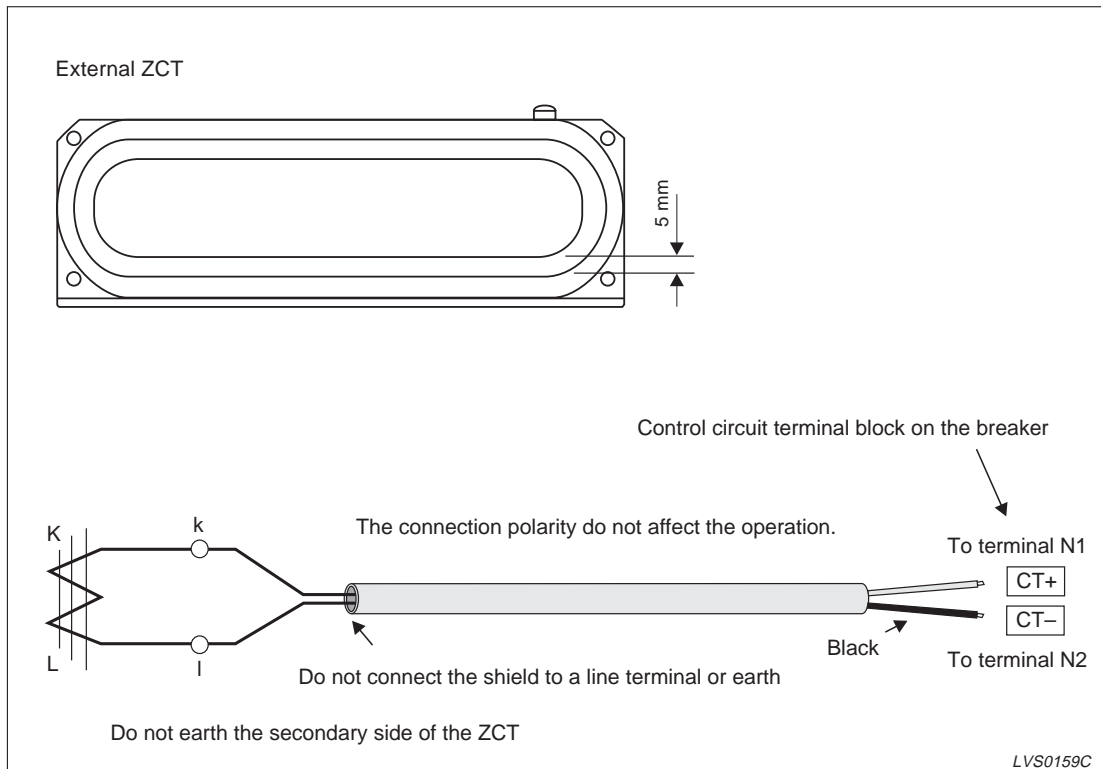

Fig. 4-72: Installing the external ZCT for load circuits

4.17.2

Precautions when installing the external ZCT on the transformer ground wire

- ① Select a ZCT bore that allows the ground wire of the transformer to pass through. For example, "15" in the model name "ZT15A" stands for a 15 mm diameter bore in the ZCT.
- ② All other large current circuits should be routed at least 200 mm away from the ZCT.
- ③ The wiring distance between the ZCT and the breaker should be 3 m or less. The wire should be shielded wire and be mounted apart from the power lines as far as possible (the ZCT is provided with 2 m of shielded wire).
- ④ Do not earth the secondary side of the ZCT.

4.17.3 Examples of connections

Earth leakage trip

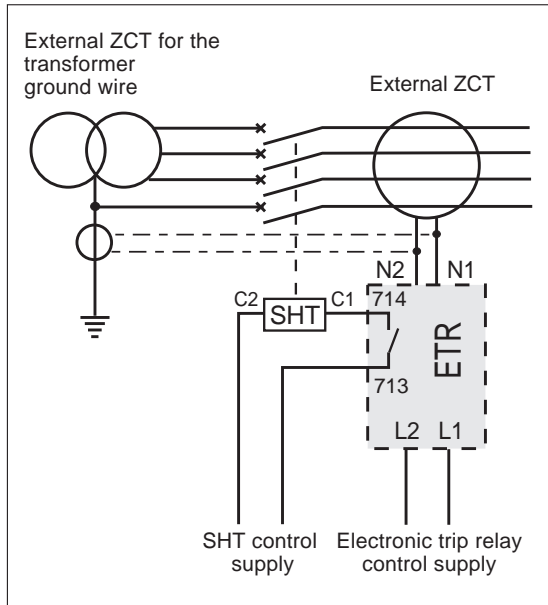

Fig. 4-73:
Earth leakage trip with an electronic trip relay (with earth leakage protection)

LVS0181C

Earth leakage alarm

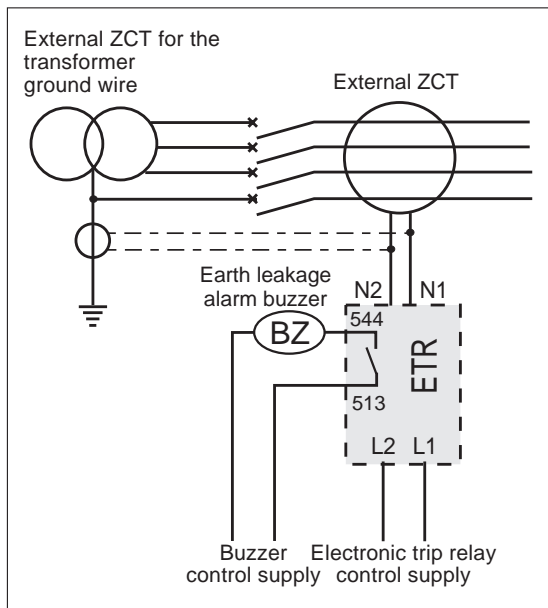

Fig. 4-74:
Earth leakage alarm with an electronic trip relais (with earth leakage protection)

LVS0180C

Types of electronic trip relay control supplies and power input terminals

| Voltage code | Voltage (V) | Input terminal |
|--------------|-------------|----------------|
| 1 | AC 100–120 | across L1 / L2 |
| | AC 200–240 | |
| 2 | DC 100–110 | across L1 / L2 |
| 3 | DC 125 | |
| 4 | DC 24 | |

Tab. 4-4:
Types of electronic trip relay control supplies and power input terminals

Precautions when using

The following precautions have to be obtained when using the earth leakage function:

- Earth leakage protection is effective only when a control supply is applied to the electronic trip relay (with an earth leakage facility).
- When the breaker is required to trip by earth leakage, an electronic trip relay (with an earth leakage facility) must be used with a shunt trip device (SHT) having a voltage of AC/DC 100–250 V or DC 24–48 V. An AC 380–460 V SHT unit is not suitable.
- Output terminals for the SHT unit are [713] [714] ([ST+] [ST-]). Do not use terminals [513] [544] ([T0+] [T3-]); these are for the alarm buzzer.
- If the breaker is tripped by earth leakage, reset the trip indicator on the electronic trip relay before closing the breaker again. If it is not reset in advance, the SHT is activated which prevents the breaker from being closed.
- To test the earth leakage function, put a test winding around the external ZCT (1 turn), apply a test current to this test winding and measure the current.

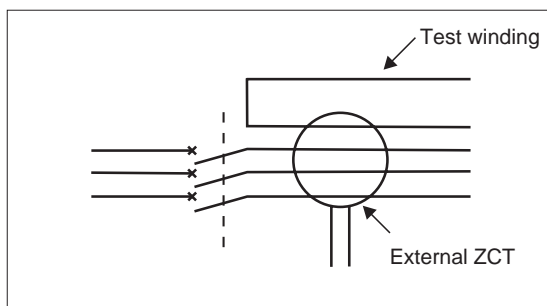

Fig. 4-75:
Testing the earth leakage function

LVS0197C

4.18 Push-button cover

This provides protection to the ON and OFF push-buttons against inadvertent operation. To open or close the breaker, push up the cover for the push-button required and press this push-button. A padlock facility is available (the padlock has to be provided by the customer) which prevents manual operation from the front side of the breaker.

4.18.1 Installation

- ① Place the button covers and the button cover frame over the push-buttons as shown in the following fig. 4-76.

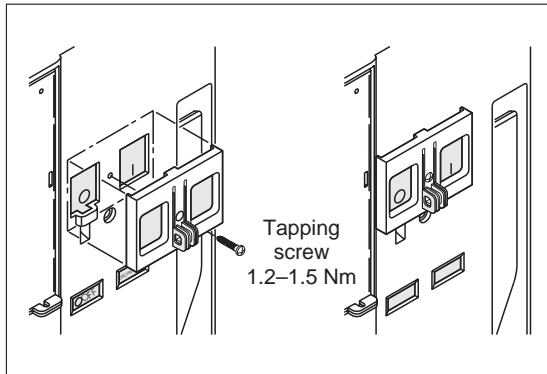

Fig. 4-76:
Installation of the push-button covers

LVS0150C

- ② Mount the button cover on the AE-SS cover by tightening the tapping screw (tightening torque: 1.2–1.5 Nm).

NOTE

- | Apply bonding agent to the top of the screw, if a locking of the screw is required.
- | For securing the button cover a standard padlock can be used.

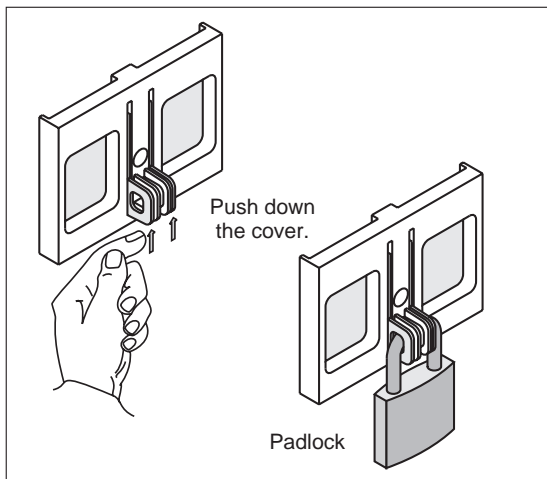

Fig. 4-77:
Applying the padlock

LVS0151C

4.19 Terminal adapter

4.19.1 Installation of front terminal adapter (FTA)

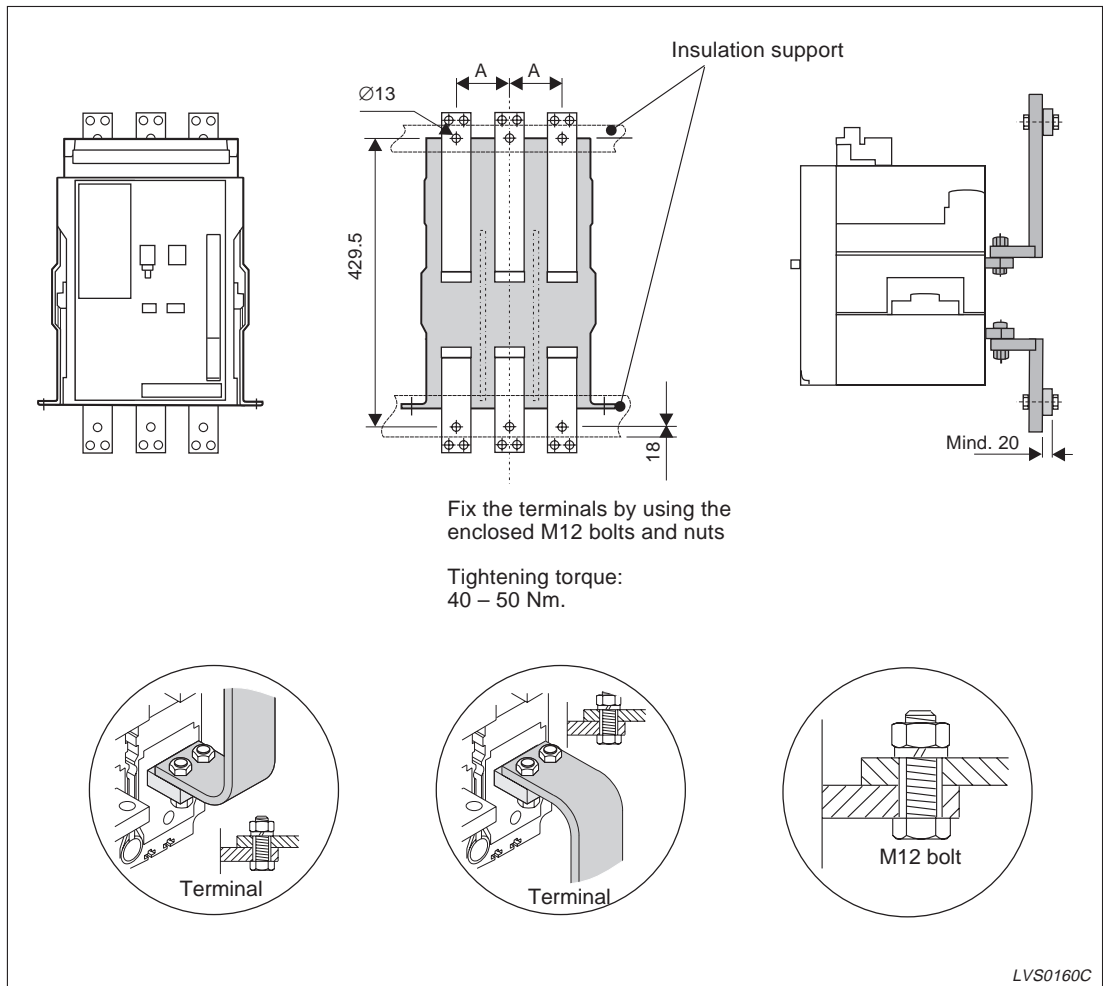

Fig. 4-78: Installation of the front terminal adapter

NOTE

Support the terminals by insulation support.

| Breaker types | Dimension A |
|---|-------------|
| AE630-SS – AE1600-SS | 85 |
| AE2000-SS – AE3200-SS AE630-SH – AE3200-SH | 130 |

Tab. 4-5:
Dimensions

NOTES

The load and line terminals should be tightened in the same plane.

The insulation support should be strong enough with regard to electro-magnetic forces (see sec. 2.7 for further details).

Maintenance

Re-tighten the front terminal adapter when maintaining the breaker.

4.19.2 Installation of vertical terminal adapter (VTA)

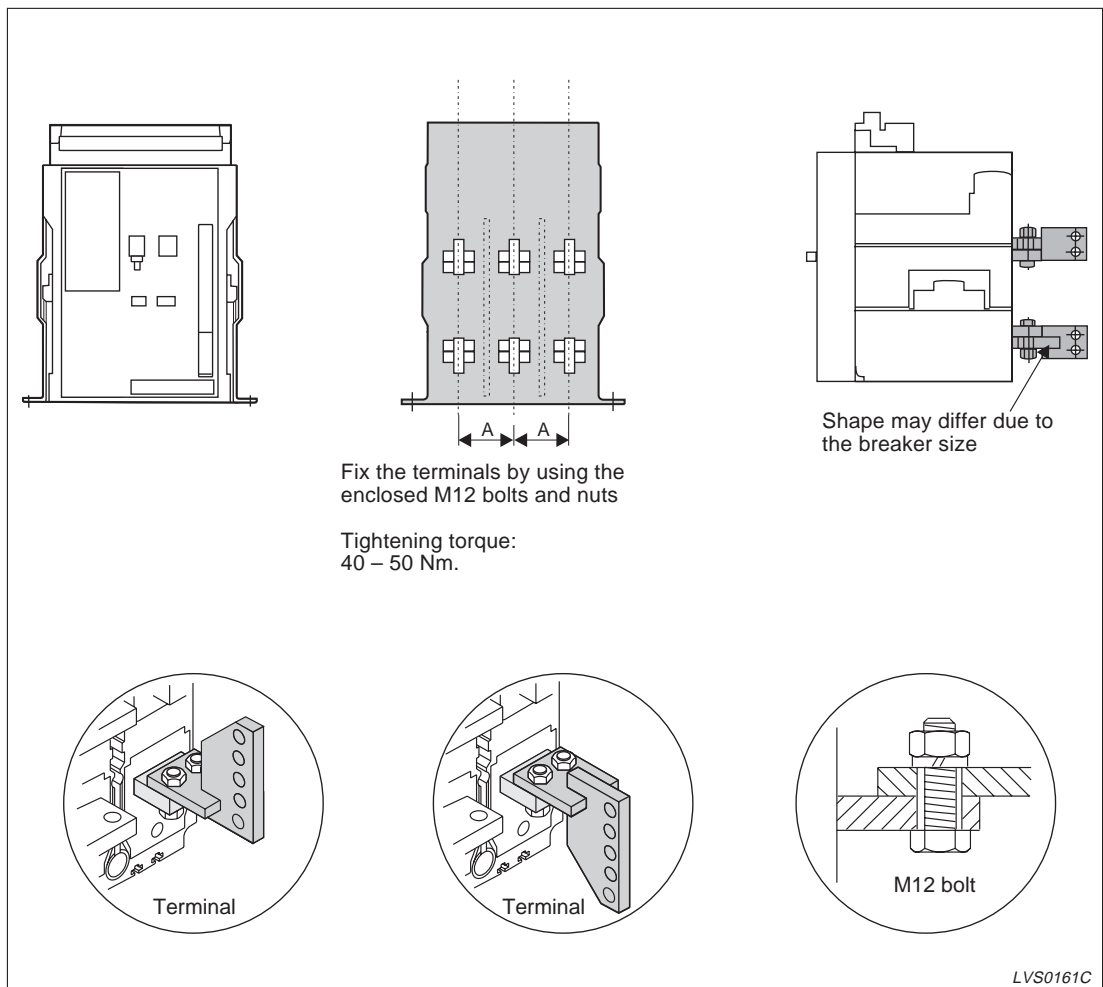

Fig. 4-79: Installation of the vertical terminal adapter

| Breaker types | Dimension A |
|---|-------------|
| AE630-SS – AE1600-SS | 85 |
| AE2000-SS – AE3200-SS AE630-SH – AE3200-SH | 130 |

Tab. 4-6:
Dimensions

NOTES

- | The load and line terminals should be tightened in the same plane.
- | Busbars should be supported fast (refer to sec. 2.7 for further details).
- | The shape of the terminal adapters may differ in accordance with the breaker type. Refer to the technical catalogue for further details.

Maintenance

Re-tighten the vertical terminal adapter when maintaining the breaker.

5 Maintenance and Inspection

Maintenance / inspection frequency and contents are different depending on the working conditions. Read through the following for details regarding sufficient maintenance and inspection.

NOTE

Maintenance and inspection is only intended to be used by **trained and fully-qualified electrical personnel** who are familiar with the safety standards required for circuit breakers and distribution systems. Project planning, installation, commissioning, maintenance and testing of the equipment may only be performed by **trained and fully-qualified electrical staff** who are familiar with the safety standards required for circuit breakers and distribution systems.

5.1 Preparation

For a routine inspection under normal conditions, proceed as follows:

After drawing out the breaker from the cradle (refer to para. 2.11), remove the cover in the following way.

- ① Remove the four M6 and one M4 cover mounting bolts.

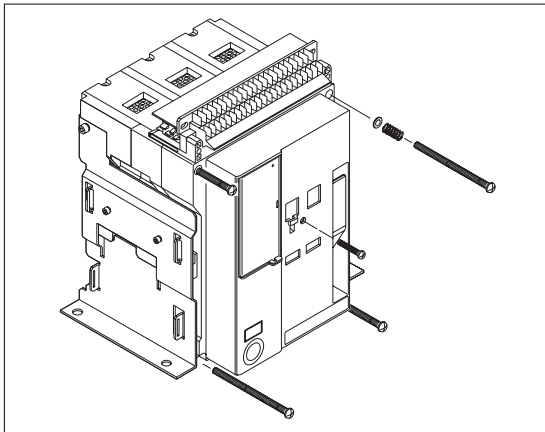

Fig. 5-1:
Removing the fixing bolts

LVS0187C

NOTE

The 4-pole breakers AE2000-SS-3200-SS have six M6 screws and one M4 screw, the 4-pole breakers AE4000-SS-6300-SS have two M6 screws and one M4 screw.

- ② Remove the cover with the charge handle pressed down in the “CHARGE” state.

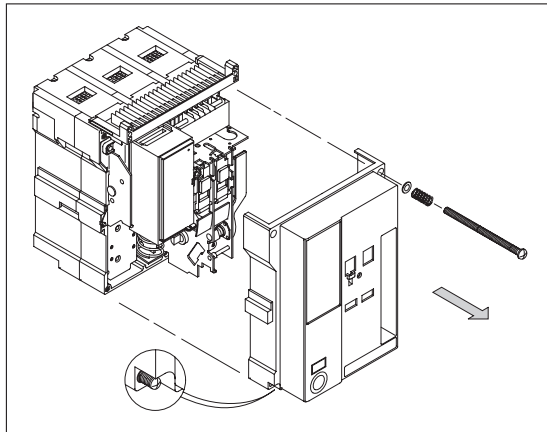

Fig. 5-2:
Removing the cover

LVS0188C



CAUTION:
For safety reasons, switch to the “DISCHARGED” and “OFF” state after removing the cover.

- ③ To remove the arc-extinguishing chambers refer to the following figures.

Use a No. 5 hexagonal wrench to loosen the M6 bolt (one for the frame 1600A or smaller and two for the frame 2000A or larger) and slide off the cover of the arc-extinguishing chamber.

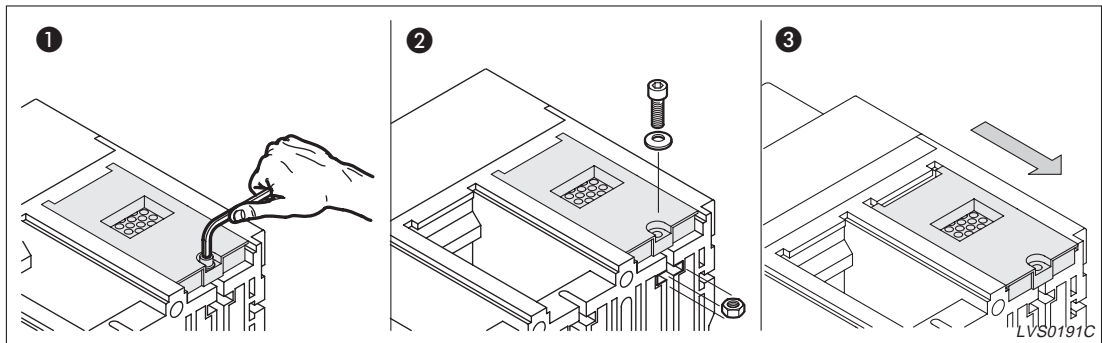

Fig. 5-3 Loosening the arc extinguishing chambers

- ④ Carefully lift out the arc-extinguishing chamber.

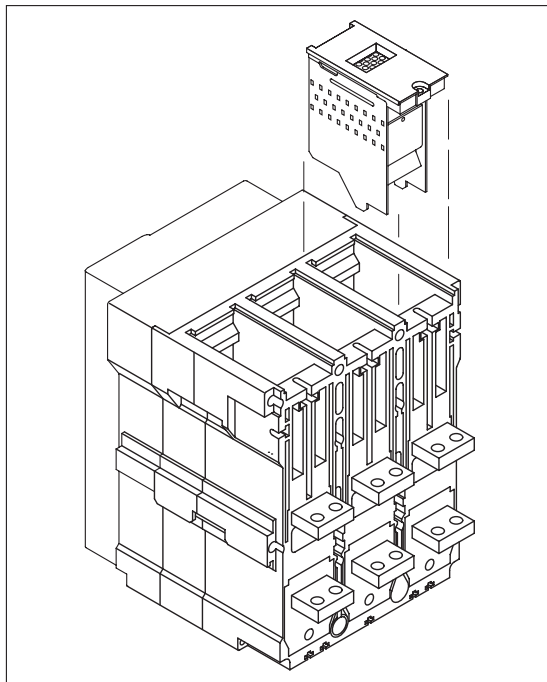

Fig. 5-4: Removing the arc extinguishing chamber

- ⑤ The breaker is now ready for inspection and maintenance work.

5.2 Troubleshooting

The following is a guide to the points to be inspected and how to proceed. In addition to regular inspections the same procedure should be followed, if a short circuit occurs.

① Breaker unit proper

| Check point | Procedure | Repair criteria | Remedial action |
|---|------------------------------------|---|--|
| Dust or dirt | Visual inspection | Clean, and with no foreign matter | Do not use a thinner to clean plastic material as a cover. Use ethyl alcohol (ethanol) to remove extreme dirt |
| Looseness of control circuit contact main terminals | Tighten with screwdriver or wrench | Tight | Tighten if necessary |
| Distortion, excessive wear or damage | Visual inspection | Absence of distortion, excessive wear or damage | Remove cause and replace parts |

Tab. 5-1: Inspection of the breaker unit

② Arc-extinguishing chamber

| Check point | Procedure | Repair criteria | Remedial action |
|---|-------------------|---|--|
| Soot or dust | Visual inspection | Clean | Blast with compressed air. Wipe with a clean, dry cloth |
| Breakage of the external frame of the chamber | Visual inspection | No scaling | Replace |
| Melting of arc-extinguishing plate | Visual inspection | No more than 5 mm of the plate edge melted away | Replace |

Tab. 5-2: Inspection of the arc-extinguishing chamber

③ Main conductors

| Check point | Procedure | Repair criteria | Remedial action |
|--------------|-------------------|---|---|
| Contact wear | Visual inspection | No underlying copper exposed due to contact melting | Replace the breaker. (If not necessary, remove dirt with sandpaper.) |

Tab. 5-3: Inspection of the main conductors

5.3 Guidelines for inspections and replacement

5.3.1 Introduction

ACB's should be periodically inspected

- to detect anomalous parts at an early stage
- to maintain the performance of the ACB through timely renewal of consumable and degrading parts
- to prevent accidents that may arise from the end of the lifetime of the equipment.

MITSUBISHI ELECTRIC suggests the following guidelines for inspection and renewals, frequency of inspections and inspection details. Please read these upon of the equipment.

NOTE

Maintenance and inspection is only intended to be used by **trained and fully-qualified electrical personnel** who are familiar with the safety standards required for circuit breakers and distribution systems. Project planning, installation, commissioning, maintenance and testing of the equipment may only be performed by **trained and fully-qualified electrical staff** who are familiar with the safety standards required for circuit breakers and distribution systems.

5.3.2 Inspections and renewals according to period and environment of usage

| Degree of usage | | Environment | Specific examples | Guidelines for inspection | Guidelines for renewal |
|----------------------------|---|---|--|---------------------------|-------------------------|
| General usage environments | 1 | Location where the air is always clean and dry | Dustproof and airconditioned electric rooms, etc. | Once every 2~3 years | Within approx. 15 years |
| | 2 | Indoor locations with little dust, etc. Locations without corrosiove gases | Distribution panels in boxes and distribution panels in individual electric rooms that are not dustproof and air-conditioned | | |
| Poor environments | 1 | Locations with salinity, high temperature and gases such as sulphur dioxide and hydrogen sulphide | Geothermal power plants, waste water, treatment plants, iron mills, paper factories, pulp factories, etc. | Once a year | Within approx. 7 years |
| | 2 | Locations with especially severe corrosive gas and dust conditions and where humans cannot stay for a long period of time | Chemical factories, quarries, mining areas, etc. | Once every half a year | Within approx. 5 years |

Tab.5-4: Inspections and renewals according to period and environment of usage

5.3.3 Inspections and replacement according to number of operation cycles

| Breaker | Guidelines for inspection | | Limit of number of operation cycles with rated current | | | | |
|---------------|---------------------------|--------------|--|--------------------|--------------|-------|-----------------------|
| | Operation cycles | | Operation cycles | | | | |
| | with rated current | without load | per hour | with rated current | without load | total | with 6x rated current |
| AE1000-SS | every 500 | every 2000 | 20 | 5000 | 10000 | 10000 | 12 |
| AE1250-SS | | | | | | | |
| AE1600-SS | | | | | | | |
| AE2000-SS | every 300 | | 10 | 1500 | | | |
| AE2500-SS | | | | | | | |
| AE3200-SS | every 100 | 1000 | | | | | |
| AE4000-SSA 3P | every 100 | every 1000 | 20 | 500 | 5000 | 5000 | 6 |
| AE4000-SSA 4P | every 50 | every 400 | 10 | | 4000 | 4000 | 3 |
| AE4000-SSC | every 50 | every 1000 | | | 5000 | 5000 | |
| AE4000-SS | | every 400 | | | 2000 | 2000 | |
| AE5000-SS | | | | | | | |
| AE6300-SS | | | | | | | |
| | | | | | | | |
| AE1000-SH | every 500 | every 2000 | 20 | 5000 | 10000 | 10000 | 12 |
| AE1250-SH | | | | | | | |
| AE1600-SH | every 300 | | | 10 | | | |
| AE2000-SH | | | 1500 | | | | |
| AE2500-SH | every 100 | | | 1000 | | | |
| AE3200-SH | | | | | | | |

Tab. 5-5: Inspections and renewals according to number of operation cycles

5.4 Concerning the inspections

5.4.1 Initial inspection

Inspections prior to applying current

Perform the following inspections after installing the ACB and before applying the current.

| Inspection item | Criteria |
|---|---|
| 1. Are the electrical wires and bus bar fastened securely to the external line connection terminals? | Must be tightened at the designated tightening torque (M12 screw: 40–50 Nm) |
| 2. Are any conductive foreign objects, such as screws, nails, processing chips from the panel and connecting lead wires for withstand voltage tests, left around the terminals? | Must be removed completely. |
| 3. Is the front cover, base, etc. cracked or damaged? | There must be no cracks or damages. |
| 4. Has the breaker been flooded or is there condensation of dew? | There must be no flooding or dew condensation. |
| 5. Measure the insulation resistance with a 500 V insulation resistance tester. | Must comply with the standards given in 5-6 |
| 6. Perform the withstand voltage test. | Must comply with the standards given in 5-6 |

Tab. 5-6: Inspections prior to applying current

Measurement locations and standards for insulation resistance and withstand voltage tests

The measurement locations for insulation resistance and withstand voltage tests are listed in the following table.

| Measurement location | Insulation resistance Test | | Withstand voltage test | |
|--|----------------------------|-----|------------------------|-----|
| | ON | OFF | ON | OFF |
| Between the live part of the main circuit and the earth | ● | ● | ● | ● |
| Between live parts of different poles | ● | — | ● | — |
| Between the power supply and the load terminals | — | ● | — | ● |
| Between the live part of the main circuit and live parts of the control/operation circuits | ● | ● | ● | ● |
| Between the live parts of the control/operation circuits and the earth | ● | ● | ● | ● |

Tab. 5-7: Measurement locations and standards

Standards for insulation resistance and withstand voltage tests

- Insulation Resistance Test: Must be no less than $5\text{M}\Omega$
(must be no less than $100\text{M}\Omega$ for the ACB alone).
- Withstand Voltage Test: Between the live part of the main circuit and the earth:
3500 V
- Between live parts of different poles:
3500 V
- Between the power supply and the load terminals:
3500 V
- Between the live part of the main circuit and the live parts of the control/operation circuits:
3500 V
- Between the live parts of the control/operation circuits and the earth:
2000 V (is not, according to the indication on the nameplate)

**CAUTION:**

In the case of dielectric check of panel board, remove the control source wires of UVT controller, otherwise UVT controller may be broken.

5.4.2 Periodic Inspections

It is recommend that periodic inspections are performed once about one month after the start of use and thereafter according to the environment for prior prevention of accidents and stable, long-term use of the ACB.

External Appearance of the ACB

| Inspection item | Inspection method | Criteria | Treatment methods |
|--|---|--|--|
| 1. Dust and soiling | Visual inspection | There must be no detrimental deposits of dust and dirt. | Blow with air upon each periodic inspection or cleand remove the dust with a dry cloth. |
| 2. Loosening of the main circuit terminals | Tighten with a torque wrench. | The tightening torque must be as designated: M12 screw: 40–50 Nm | Tighten additionally if necessary M12 screw: 40–50 Nm |
| 3. Flooding, immersion in water | There must be no flooding or immersion. | There must be no flooding or immersion. | Replace the product if flooding or immersion has occurred. |
| 4. Loosening of control terminals | Tighten with a screw driver. | Must be tightened securely. | Tighten additionally if necessary. |
| 5. Cracks, breakage or deformation of the front cover, base and control circuit terminal block | Visual inspection | There must be no cracks, breakage or deformation. | Replace the parts if there are any anomalies at the front cover or the control circuit terminal block. |

Tab. 5-8: External appearance

Conductive part of the main circuit

| Inspection item | Inspection method | Criteria | Treatment methods |
|---|--|---|--|
| 1. Wear of contacts | Measurement and visual inspection (refer to p. 5-17) | Must be no less than 2 mm. | Replace the breaker if at or below the standard value |
| 2. Discoloration of movable and fixed conductors | Visual inspection | There must be no detrimental discoloration. | Replace the ACB if there is any detrimental discoloration. |
| 3. Soiling of the main circuit conductors | Visual inspection | There must be no detrimental deposits of dust or soot. | Put methyl alcohol on a cloth, etc and wipe. |
| 4. Discoloration and deformation of the main circuit junction | Visual inspection | There must be no discoloration of the junction or deformation of the flat spring. | Replace the cradle if there are any abnormalities. |
| 5. Measurement of insulation resistance | Perform in accordance with section 5.3.1 | Must be no less than 5 MΩ (must be no less than 100 MΩ for the AE-SS alone). | Remove the dust, clean or replace the ACB. |

Tab. 5-9: Conductive part of the main circuit

Arc extinguishing chamber

| Inspection item | Inspection method | Criteria | Treatment methods |
|---|--------------------------------------|--|--|
| 1. Soot and stains | Visual inspection | No detrimental deposits of dust and dirt | Remove dust and clean upon each inspection. |
| 2. Breakage of the arc extinguishing chamber | Visual inspection | There must be no breakage | Replace if there are any anomalies. |
| 3. Condition of the arc extinguishing plate | Visual inspection | Welded area should be less than 5 mm | Replace if there are any anomalies. |
| 4. Loosening of the arc extinguishing chamber fastening screw | Tighten with a wrench for M6 screws. | Must be tightened securely. | Tighten additionally if necessary. M6: 9 ~ 11Nm |

Tab. 5-10: Arc extinguishing chamber**Switching mechanism**

| Inspection item | Inspection method | Criteria | Treatment methods |
|--|-------------------|---|---|
| 1. Manual charge operation of the closing spring | Manual operation | Must be able to perform the charge operation smoothly. | Repair or replace the ACB if there are any abnormalities. |
| 2. Manual closing and tripping operation | Manual operation | Must be able to perform closing and tripping reliably with the manual operation button. | Replace the ACB if closing or tripping cannot be performed. |

Tab. 5-11: Switching mechanism part**Electronic trip device**

| Inspection item | Inspection method | Criteria | Treatment methods |
|--|-------------------|---|---|
| 1. External appearance of the electronic trip device | Visual inspection | There must be no breakage or deformation of the external parts and the setting dials. | Replace the electronic trip device if there is any breakage or deformation. |
| 2. Operating characteristics of the electronic trip device | Measurement | User AE-SS tester (Y-160, Y-2000) to confirm that the characteristics are within the standard values. | Replace the electronic trip device if the measured values deviate from the standard values. |

Tab. 5-12: Electronic trip device

Accessory devices (general accessory devices)

| Inspection item | Inspection method | Criteria | Treatment methods |
|--|----------------------------------|---|--|
| 1. Closing coil (CC) Shunt trip device (SHT) | Electrical operation | Must operate reliably and without difficulty within the operation voltage range indicated in the "Instruction Manual". | Replace the closing coil or the shunt trip device if there are any operational abnormalities. |
| 2. Auxiliary switch (AX) | Check continuity of AXa and AXb. | Must switch in accordance with the conditions of the ACB. | Replace the auxiliary switch if there are any operation abnormalities. |
| 3. Motor charging device (MD) | Electrical operation | Must complete the charging reliably and without difficulty within the designated time and the voltage range indicated in the Instruction Manual. | Replace the motor changing device if there are any operational abnormalities. |
| 4. Under voltage trip device (UVT) | Electrical operation | Must be able to close reliably upon application of a voltage that is 85 % of the rated voltage and to trip and disable closing by the time the voltage reaches 45 % of the rated voltage. | Replace the under voltage trip device if there are any operational abnormalities. |
| 5. Safety shutter (SST) | Drawout/insertion operation | (1) There must be no breakage of the parts. | ① Replace broken parts if any. |
| | | (2) Must be able to perform the drawout/insertion operation without any difficulty. | ① Remove any broken parts that impair the drawout/insertion operation. ② Replace the cradle if the drawout/insertion operation cannot be performed. |
| 6. Cell switch (CL) | Drawout/insertion operation | Must switch reliably to the "DISCONNECTED", "TEST" and "CONNECTED" positions. | Replace the cell switch if there are any operational abnormalities. |

Tab. 5-13: Accessory devices

5.4.3 Inspections after the breaking operation

Inspect the items for periodic inspection in section 5.4.2 when the ACB has performs a breaking operation as a result of an overload current or a short-circuit current.

Reuse is possible if the criteria are satisfied.

However, it is recommended that the ACB be replaced soon as possible after it has interrupted a large fault current. The ACB should be monitored for unusual temperature rises and other abnormalities until replacement occurs. Refer to the following chart regarding the level of the breaking currents and the treatments to be performed:

| Level of the breaking current | Level of ACB damage | Treatment |
|--|---|---|
| 1. Fault current of no more than 10 times the rated current (long-time-delay, short-time-delay region) | (1) Abnormalities of the external parts cannot be detected visually. (2) Slight wear of contacts, soiling by shoot, etc. | Reusable (1) Refer to section 5.3.3 regarding the switching operation lifetime at the rated current. (2) The equipment does have the capacity to perform 12 operation cycles even with a current that is 6 times the rated current. |
| 2. Fault current of about 20 times the rated current (instantaneous region) | (1) There is slight overall soiling of the exhaust ports by soot. (2) There is overall damage of the contacts and the arc extinguishing chamber but only to a slight degree. | Reusable. O-CO-CO cycles can be performed at the rated breaking current. |
| 3. Large currents close to the rated breaking capacity | (1) There is significant overall soiling of the exhaust ports by soot. (2) The contacts and the arc extinguishing chamber also suffer considerable damage. | (1) Immediate replacement is desirable. (2) If immediate replacement is not possible, the breaker can be used carefully by gradually reducing the rated current, etc, provided that the criteria in section 5.4.3 are satisfied. As an additional test, perform the withstand voltage test of the lice part of the main circuit of the ACB at twice times the rated insulation voltage, in other words, at 2000 V. However, renew as soon as possible. |

Tab. 5-14: Inspections

NOTES

In the case of the electronic trip device with the trip indication function, it can be determined whether the cause of the tripping lies in the long-time-delay, short-time-delay or the instantaneous region.

If the magnitude of the fault current cannot be estimated, treat according to point 3 of section 5.4.3.

5.5 Troubleshooting

5.5.1 The breaker cannot close

| Type and condition of abnormality | Probable cause | Treatment | | |
|---|---|---|---|--|
| | | Primary treatment | Secondary treatment | |
| The closing operation will not be performed. | The OFF-lock device (CYL, CAL, Padlock) is not released. | Release the OFF-lock device (CYL, CAL, Padlock) | Please contact MITSUBISHI ELECTRIC if closing cannot be performed even upon performing the primary treatment. | |
| | The drawout position is not appropriate. | Set to either of the "DISCONNECTED"; "TEST" or the "CONNECTED" positions. | | |
| | The drawout handle is inserted. | Remove the drawout handle. | | |
| | Voltage is not applied to the UVT. | Apply right voltage to the UVT. | Refer to the section "Abnormalities of the UVT" if there is an abnormality of the UVT. | |
| | The closing spring is not charged. | Charge the coil. | Please contact our company if charging cannot be performed manually. | Refer to the section "Charging disabled" if electrical charging is not possible. |
| | | | | — |
| The closing coil does not operate. (Manual closing is able.) | If the voltage is not applied, examine the operation circuit. If the voltage is applied, check the contact of the fasten terminal at the lower part of the control circuit terminal block. | — | Replace the closing coil if there are no abnormalities in the contact of the fasten terminals. | |
| | | | — | |
| The closing operation is performed. | Tripping (OFF) is performed simultaneously with the closing operation. (1) The UVT coil is malfunctioning | Check whether or not the UVT is malfunctioning. | Replace the UVT coil if the UVT coil is malfunctioning. | |
| | (2) The spring between the closing latch and the trip latch has come off. | — | Please contact MITSUBISHI ELECTRIC. | |
| | (3) The fixing screws of the closing latch and the trip latch are loose. | Remove the foreign object | Please contact MITSUBISHI ELECTRIC if any deformation or breakage of the component parts has been noted. | |
| | The ON button is broken | — | Please contact MITSUBISHI ELECTRIC. | |
| | The ON button cannot be pressed | — | Please contact MITSUBISHI ELECTRIC. | |

Tab. 5-15: Troubleshooting when the breaker cannot close

5.5.2 Switching off is disabled

| Type and condition of abnormality | Probable cause | Treatment | |
|--|--|---|--|
| | | Primary treatment | Secondary treatment |
| Switching off the braker is not possible | Tripping does not perform even after pushing the OFF button. | — | Please contact MITSUBISHI ELECTRIC. |
| | The shunt trip device (SHT) will not operate. | If the voltage is not applied, examine the control circuit. | If the voltage is not supplied check the control circuit. |
| | The shunt trip device (SHT) will not operate although the voltage is applied. (Manual OFF operation is able.) | If the voltage is applied: ① Check the contact of the fasten terminals S+ and S- below the control circuit terminal block. | Examine the SHT coil if there are no abnormalities. |
| | | ② Remove the SHT and pull out the connector and check the SHT operation with rated voltage. (Supply voltage less than 5 sec.) | Replace the SHT coil if there is no continuity. Examine the AX unit if there is continuity. Replace the AX unit if there is no continuity. |
| | | With the ACB closed remove the S+ and S- terminals of the control circuit terminal block and the SHT coil from the connector and check the continuity of the connector. | |
| | The OFF button is broken | — | Please contact MITSUBISHI ELECTRIC. |
| The OFF button cannot be pressed | — | Please contact MITSUBISHI ELECTRIC. | |

Tab. 5-16: Troubleshooting when switching off is not possible

5.5.3 Charging is not possible

| Type and condition of abnormality | Probable cause | Treatment | |
|---|--|--|--|
| | | Primary treatment | Secondary treatment |
| Cannot perform manual charging. | The manual handle is broken. | — | Please contact MITSUBISHI ELECTRIC. |
| | There is an abnormality in the switching mechanism. | — | Please contact MITSUBISHI ELECTRIC. |
| Electrical charging cannot be performed. | The voltage is not applied. | Apply the voltage. | — |
| | The voltage is applied. | The motor won't turn. ① Check the contact of the fasten terminals, M+ and M-, below the control circuit terminal block. In the case of DC, check the polarity also. | Secure the contact if there is an abnormality. Replace the motor unit if there are no abnormalities. |
| | | ② Check the contact of the connector of the motor unit. | |
| The motor turns but won't charge. ① Examine whether or not manual charging is possible | Replace the motor unit if there are no abnormalities. Please contact MITSUBISHI ELECTRIC if there is an abnormality. | | |

Tab. 5-17: Troubleshooting when charging is not possible

5.5.4 Unusual temperature rise

| Type and condition of abnormality | Probable cause | Treatment | |
|-------------------------------------|--|----------------------------|---|
| | | Primary treatment | Secondary treatment |
| There is a unusual temperature rise | The fastening of the connecting conductor is loose. | — | Replace the ACB if discoloration of the conductor or burning of the terminal mold is noted. |
| | The contact pressure flat sprint of the junction is damaged. | — | Replace the cradle. |
| | The contact resistance of the contact has increased. | Clean the contact surface. | Replace the ACB if the temperature does not fall even upon cleaning the contact surface. |
| | The wear of the contact is severe. | — | Replace the ACB. |
| | Current flow is large. | Decrease the current flow. | — |

Tab. 5-18: Troubleshooting when an unusual temperature rise occurs

5.5.5 Abnormality of the electronic trip device

| Type and condition of abnormality | Probable cause | Treatment | |
|--|---|--|--|
| | | Primary treatment | Secondary treatment |
| The electronic trip device trips unnecessarily | Incorrect setting of the electronic trip relay. | Change to an appropriate setting. | If tripping is performed even upon setting the maximum setting, change to a breaker with a larger uninterrupted current capacity. |
| | Failure of the electronic trip relay. | — | Replace the electronic trip relay. CAUTION: Replacement of the trip relay is only allowed by trained and fully-qualified electrical personnel! Please contact MITSUBISHI ELECTRIC. |
| The breaker will not trip even when an overcurrent flows | Malfunction of the electronic trip relay. | Check tripping operation with a tester, etc. | Check the following connections if there are no abnormalities. Replace the electronic trip relay if there is an abnormality. CAUTION: Replacement of the trip relay is only allowed by trained and fully-qualified electrical personnel! Please contact MITSUBISHI ELECTRIC. |
| | Disconnection of the connection between the CT connector and the electronic trip relay. | Connect the CT connector and the electronic trip relay securely. | Examine the trip coil if there are no abnormalities. |
| | The trip coil will not operate. (1) The connector of the trip coil is disconnected. | Connect the connector of the trip coil securely. | Replace the trip coil if there are no abnormalities. |
| | The ACB will no trip even though the trip coil is operation | — | Replace the ACB. |

Tab. 5-19: Troubleshooting when problems with the electronic trip device occur

5.5.6 Drawout/insertion operation is not possible

| Type and condition of abnormality | Probable cause | Treatment | |
|---|---|---|--|
| | | Primary treatment | Secondary treatment |
| Drawout/insertion operation is not possible | The drawout handle cannot be inserted. | Insert the drawout handle after pushing the OFF button. | Please contact MITSUBISHI ELECTRIC. |
| | The lock plate cannot be pushed in. | Turn the drawout handle slightly to the right and left and push in the lock plate at a position where the lock plate can be pushed in easily. | Please contact MITSUBISHI ELECTRIC. |
| | The lock plate does not protrude out at the "TEST" or "CONNECTED" position. | — | Replace the drawout indicator. |
| | The stopper pin has broken and although the lock plate protrudes out at the "TEST" and "CONNECTED" position, the insertion operation will not lock. | — | Replace the drawout indicator. |
| | The indicator on the drawout indicator will not change. | — | Replace the drawout indicator. |
| | The drawout handle will not turn. | — | Please contact MITSUBISHI ELECTRIC. |
| | The safety shutter (SST) is broken and is impairing the drawout/insertion operation. | Remove the broken parts. | Replace the broken part. |
| | The junction is broken and is impairing the drawout/insertion operation. | — | Please contact MITSUBISHI ELECTRIC. |
| | The automatic connection terminal (ATC) is broken and is impairing the drawout/insertion operation. | — | Replace the automatic connection terminal (ATC). |

Tab. 5-20: Troubleshooting when drawout/insertion operation is not possible

5.5.7 Malfunction of peripheral devices

| Type and condition of abnormality | Probable cause | Treatment | |
|--|--|---|---|
| | | Primary treatment | Secondary treatment |
| The safety shutter (SST) will not operate | The barrier of the safety shutter (SST) is broken. | — | Replace the broken part. |
| | The rod of safety shutter (SST) unit is broken. | — | Replace the broken part. |
| The automatic connection terminal (ATC) will not make contact at the "TESTED" and "CONNECT" positions. | The mold of the automatic connection terminal is broken. | — | Replace the broken part. |
| | The blade of the automatic connection terminal is deformed. | — | Replace the broken part. |
| The UVT will not draw in (anomaly of the UVT controller) | Voltage is not applied to the input terminal. | Check the input voltage. | Examine the power supply circuit if the voltage is not applied. |
| | The trip terminals, US+(DT1) and US- (DT2), are shorted (are open in the case of b-contact types). | Check whether the trip terminals, US+(DT1) and US- (DT2), are shorted (whether they are open in the case of b-contact types). | Examine the output terminals if there are no abnormalities. |
| | There is no output at the output terminals, U+(J1) and U- (J2). | Check the output voltage. As the voltage is switching voltage. Mean voltage approx. DC25V. (Peak DC100V) | Replace the UVT controller if there is no output voltage. Examine the UVT coil if the voltage is outputted. |
| | The UVT coil is disconnected. | Check the continuity of the UVT coil. | Replace the UVT coil if there is no continuity. |
| The auxiliary switch will not switch over. | The connector is disconnected. | Check the contact of the automatic connection terminal (ATC). | Replace the auxiliary switch if there are no abnormalities. |
| | Breakage of the operating parts of the auxiliary switch (ACB main unit). | — | Please contact MITSUBISHI ELECTRIC. |

Tab. 5-21: Troubleshooting when there are malfunctions at the peripheral devices

A Appendix

A.1 Specifications

A.1.1 Technical notes

Line-side insulation clearance

When the short-circuit current is interrupted, ionized gas blows out discharged from the exhaust port of the arc-extinguishing chamber. Therefore, it is recommended to provide a clearance as shown in table A-1. Maintenance is possible with the following clearances.

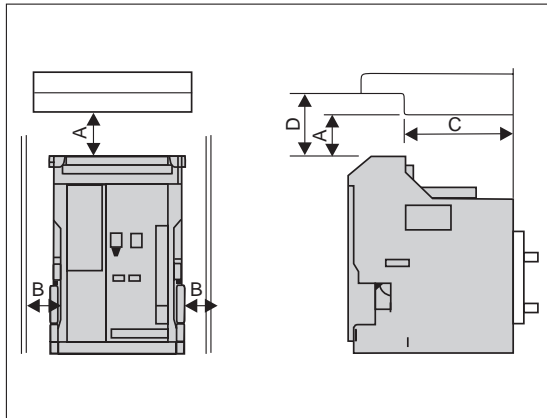

Fig. A-1:
Insulation clearances

LVS0195C

| Type | | AE1000-SS – AE3200-SS; AE4000-SSC; AE4000-SSA | AE1000-SS – AE3200-SH; AE4000-SS – AE6300-SS |
|---|---|--|---|
| Operational voltage | | AC 600 V or less | AC 690 V or less |
| Fixed type | A | *1) 0 | *1) 100 |
| | B | *3) 50 | *3) 50 |
| | C | 162 | 162 |
| | D | *2) 50 | *2) 50 |
| Drawout type | A | 0 | 100 |
| | B | *3) 50 | *3) 50 |
| | C | 240 | 240 |
| | D | *2) 50 | *2) 50 |
| *1) 300 mm or more clearance is necessary to inspect the arc-extinguishing chamber and contacts. *2) The wiring space required for the control terminal block *3) Apply for further detail in case dimension B becomes larger when the UVT controller, the mechanical interlock, door interlock, etc., are installed. | | | |

Tab. A-1: Dimensions

NOTE

High pressured gas blows out from the breaker during breaking operation. In case of installation in a enclosure, exhaust port should be prepared to reduce the pressure and temperature.

Reversing the line side and the load side for connection

The line side and the load side can be reversed for connection. Since the insulation is reinforced in the breaker, the breaker is used safely.

A.2 Operating conditions

A.2.1 Normal operating conditions

If the following normal standard working conditions are all met under ordinary conditions, the AE series air circuit breaker may be used unless otherwise specified.

Ambient air temperature

A range of max. +40°C to min. -5°C is recommended. However, the average over 24 hours must not exceed +35°C.

Altitude

2,000 m or less

Environmental conditions

The air must be clean, and the relative humidity should be 85 % or less at a maximum of +40 °C. 90 % or less is acceptable at +20 °C.

Installation conditions

When installing the AE series air circuit breaker, refer to the installation instructions in the catalogue and in the instruction manual.

A.2.2 Special operating conditions

In case of special operating conditions, modified air circuit breakers are available. Please specify when ordering.

Special ambient temperature

If the ambient temperature exceeds +40 °C, the uninterrupted current rating will be reduced. The reduction value is given in tab. A-3.

Special environmental conditions

If the breaker is used at high temperatures and / or high humidity, the insulation durability and other electrical / mechanical features may deteriorate. Therefore, the breaker should be specially treated. Moisture fungus treatment with increased corrosion-resistance is recommended.

Since some parts may pose problems due to corrosion in an environment where corrosive gas results from corrosion, the increased extra-corrosion proof specification is recommended.

Special altitude

If the breaker is used at an altitude of 2,000 m or higher, the heat radiation rate is reduced decreasing the operating voltage rating, continuous current capacity and breaking capacity. Moreover, the durability of the insulation is decreased owing to the atmospheric pressure. Apply for further details.

A.2.3 Internal resistance, reactance and power consumption

| Type | | Internal resistance (mΩ) | Reactance (mΩ) | Power consumption (W) |
|------------|--------------|--------------------------|----------------|-----------------------|
| AE1000-SS | Fixed type | 0.026 | 0.060 | 26 |
| | Drawout type | 0.040 | 0.091 | 40 |
| AE1000-SH | Fixed type | 0.018 | 0.047 | 18 |
| | Drawout type | 0.028 | 0.071 | 28 |
| AE1250-SS | Fixed type | 0.024 | 0.060 | 38 |
| | Drawout type | 0.038 | 0.091 | 60 |
| AE1250-SH | Fixed type | 0.016 | 0.047 | 25 |
| | Drawout type | 0.026 | 0.071 | 41 |
| AE1600-SS | Fixed type | 0.016 | 0.063 | 41 |
| | Drawout type | 0.030 | 0.095 | 77 |
| AE1600-SH | Fixed type | 0.014 | 0.047 | 36 |
| | Drawout type | 0.024 | 0.071 | 61 |
| AE2000-SS | Fixed type | 0.010 | 0.047 | 40 |
| | Drawout type | 0.020 | 0.071 | 80 |
| AE2000-SH | Fixed type | 0.012 | 0.047 | 48 |
| | Drawout type | 0.022 | 0.071 | 88 |
| AE2500-SS | Fixed type | 0.008 | 0.047 | 50 |
| | Drawout type | 0.018 | 0.071 | 113 |
| AE2500-SH | Fixed type | 0.010 | 0.047 | 63 |
| | Drawout type | 0.020 | 0.071 | 125 |
| AE3200-SS | Fixed type | 0.007 | 0.048 | 72 |
| | Drawout type | 0.014 | 0.072 | 143 |
| AE3200-SH | Fixed type | 0.009 | 0.048 | 92 |
| | Drawout type | 0.016 | 0.072 | 164 |
| AE4000-SSA | Fixed type | 0,009 | 0,048 | 144 |
| | Drawout type | 0,015 | 0,072 | 240 |
| AE4000-SSC | Fixed type | 0.008 | 0.048 | 128 |
| | Drawout type | 0.014 | 0.072 | 224 |
| AE4000-SS | Drawout type | 0.013 | 0.062 | 210 |
| AE5000-SS | Drawout type | 0.011 | 0.062 | 275 |
| AE6300-SS | Drawout type | 0.0085 | 0.062 | 340 |

Tab. A-2: Internal resistance, reactance and power consumption

NOTE

| The values above are applicable for one pole.

A.2.4 Deratings by ambient temperature

| Standard | Ambient temperature | AE1000-SS AE1000-SH | AE1250-SS AE1250-SH | AE1600-SS AE1600-SH | AE2000-SS AE2000-SH | AE2500-SS AE2500-SH | AE3200-SS AE3200-SH |
|--|---------------------|------------------------|------------------------|------------------------|------------------------|------------------------|------------------------|
| IEC 947-2, EN 60947-2, VDE 0660, BS4752 | 40 °C | 1000 | 1250 | 1600 | 2000 | 2500 | 3200 |
| | 45 °C | 1000 | 1250 | 1600 | 2000 | 2500 | 3200 |
| | 50 °C | 1000 | 1250 | 1600 | 2000 | 2500 | 3200 |
| | 55 °C | 1000 | 1250 | 1550 (1600) | 2000 | 2450 | 3000 |
| | 60 °C | 1000 | 1200 (1250) | 1500 (1600) | 2000 | 2350 | 2900 |
| JIS C8372, JIS C8370 | 40 °C | 1000 | 1250 | 1600 | 2000 | 2500 | 3200 |
| | 45 °C | 1000 | 1250 | 1600 | 2000 | 2500 | 3200 |
| | 50 °C | 1000 | 1250 | 1500 (1600) | 2000 | 2500 | 3000 |
| | 55 °C | 1000 | 1200 (1250) | 1450 (1650) | 2000 | 2350 | 2900 |
| | 60 °C | 1000 | 1150 (1250) | 1400 (1600) | 2000 | 2250 | 2800 |
| LR, AB, GL,DNV, BV | 45 °C | 1000 | 1250 | 1600 | 2000 | 2500 | 3200 |
| | 50 °C | 1000 | 1250 | 1600 | 2000 | 2500 | 3200 |
| | 55 °C | 1000 | 1250 | 1550 | 2000 | 2450 | 3050 |
| | 60 °C | 1000 | 1250 | 1550 | 2000 | 2350 | 2900 |
| NK | 45 °C | 1000 | 1250 | 1600 | 2000 | 2500 | 3200 |
| | 50 °C | 1000 | 1250 | 1500 (1600) | 2000 | 2500 | 3000 |
| | 55 °C | 1000 | 1200 (1250) | 1450 (1600) | 2000 | 2350 | 2900 |
| | 60 °C | 1000 | 1200 (1250) | 1400 (1600) | 2000 | 2250 | 2800 |

Tab. A-3: Current ratings by ambient temperature (1)

NOTES

| Test conditions and conductor size are based on the referring standards.

| The values given in brackets indicate current ratings by ambient temperature for the AE-SH type only.

| Standard | Ambient temperature | AE4000-SSA | AE4000-SSC | AE4000-SS | AE5000-SS | AE6300-SS |
|--|---------------------|-------------|------------|-----------|-----------|-----------|
| IEC 947-2, EN 60947-2, VDE 0660, BS4752 | 40 °C | 4000 | 4000 | 4000 | 5000 | 6300 |
| | 45 °C | 3800 | 3800 | 4000 | 5000 | 6000 |
| | 50 °C | 3650 | 3650 | 4000 | 5000 | 5750 |
| | 55 °C | 3500 | 3500 | 3900 | 5000 | 5500 |
| | 60 °C | 3300 | 3300 | 3750 | 4750 | 5200 |
| JIS C8372, JIS C8370 | 40 °C | 3600 | 3600 | 4000 | 5000 | 6000 |
| | 45 °C | 3500 | 3500 | 3800 | 4800 | 5800 |
| | 50 °C | 3350 | 3350 | 3600 | 4600 | 5600 |
| | 55 °C | 3200 | 3200 | 3400 | 4400 | 5450 |
| | 60 °C | 3050 | 3050 | 3200 | 4200 | 5250 |
| LR, AB, GL, DNV, BV | 45 °C | — | 3800 | 3800 | 4700 | 6000 |
| | 50 °C | — | 3650 | 3600 | 4450 | 5750 |
| | 55 °C | — | 3500 | 3400 | 4150 | 5500 |
| | 60 °C | — | 3300 | 3200 | 3850 | 5200 |
| NK | 45 °C | — | 3500 | 4000 | 5000 | 5700 |
| | 50 °C | — | 3350 | 3800 | 4800 | 5500 |
| | 55 °C | — | 3200 | 3650 | 4600 | 5300 |
| | 60 °C | — | 3050 | 3500 | 4400 | 5100 |

Tab. A-4: Current ratings by ambient temperature (2)

NOTES

| Test conditions and conductor size are based on the referring standards.

| The values given in brackets indicate current ratings by ambient temperature for the AE-SH type only.

A.3 Index

A

| | |
|--|------|
| Accessories | 4-1 |
| Advices for battery recycling. | 3-17 |
| Auxiliary switch (AX) | 4-3 |

B

| | |
|------------------------|-----|
| B type relay | 3-8 |
|------------------------|-----|

C

| | |
|--|------|
| Castell lock (CAL) | 4-16 |
| Cell switch (CL) | 4-13 |
| Characteristics setting. | 3-4 |
| Charging operation | 2-25 |
| Checking the trip characteristics. | 3-14 |
| Closing coil (CC) | 4-6 |
| Closing/opening operation | 2-27 |
| Connections | 2-18 |
| Counter (CNT). | 4-17 |
| Cylinder lock (CYL) | 4-15 |

D

| | |
|-------------------------------|------|
| Dimensions | 2-4 |
| Door interlock (DI) | 4-33 |
| Drawout operation. | 2-29 |

E

| | |
|-------------------------------------|------|
| Electrical operation | 2-28 |
| Electromagnetic force | 2-20 |
| Electronic trip relay | 3-1 |
| External view of breakers | 1-1 |

F

| | |
|--|------|
| Field tester. | 3-14 |
| Front terminal adapter (FTA) | 4-48 |

G

| | |
|-------------------------------------|-----|
| Guidelines for inspections. | 5-5 |
|-------------------------------------|-----|

H

| | |
|--------------------|-----|
| Handling | 2-2 |
|--------------------|-----|

I

| | |
|---|------|
| Insert operation | 2-30 |
| Inspection | 5-1 |
| Installation | 2-13 |
| Internal construction of breakers | 1-5 |

M

| | |
|---|------|
| M type relay | 3-6 |
| Maintenance | 5-1 |
| Manual operation | 2-27 |
| Mechanical interlock (MI) | 4-28 |
| Mis-insertion preventor (MIP) | 4-26 |
| Motor charging device (MD) | 4-10 |

O

| | |
|-------------------------------------|------|
| Opening/closing operation | 2-27 |
| Operating characteristics | 3-1 |
| Operating conditions. | A-2 |
| Operating systems | 3-12 |
| Operation. | 3-1 |

P

| | |
|----------------------------|------|
| Push-button cover. | 4-47 |
|----------------------------|------|

S

| | |
|------------------------------------|------|
| S type relay | 3-4 |
| Safety lock kit | 4-20 |
| Safety shutter (SST) | 4-18 |
| Setting example | 3-10 |
| Shorting b-contact (SBC) | 4-23 |
| Shunt trip device (SHT). | 4-5 |
| Storage | 2-12 |

T

| | |
|----------------------------|------|
| Technical notes | A-1 |
| Terminals | 2-24 |
| Test jumper (TJ) | 4-40 |
| Troubleshooting | 5-13 |

U

| | |
|--|-----|
| Undervoltage trip device (UVT) | 4-7 |
| Unpacking | 2-1 |

V

| | |
|---|------|
| Vertical terminal adapter (VTA) | 4-49 |
|---|------|

W

| | |
|--------------------------|------|
| Weight | 2-11 |
| Wiring diagram | 2-21 |

Y

| | |
|-------------------------------|------|
| Y-160 field tester | 3-15 |
| Y-2000 field tester | 3-18 |

Z

| | |
|--|------|
| ZCT for load circuits/external | 4-43 |
|--|------|

| HEADQUARTERS | EUROPEAN REPRESENTATIVES | EUROPEAN REPRESENTATIVES | MIDDLE EAST REPRESENTATIVE |
|---|---|--|---|
| MITSUBISHI ELECTRIC EUROPE B.V. German Branch Gothaer Straße 8 D-40880 Ratingen Phone: 02102 / 486-0 Fax: 02102 / 486-11 20 e mail: megfa-mail@meg.mee.com | EMAC S.A. BELGIUM Industrialaan 1 B-1702 Groot-Bijgaarden Phone: +32 (0) 2 / 481 02 11 Fax: +32 (0) 2 / 481 03 01 e mail: bpa@emac.be INEA CR d.o.o. CROATIA Drvinje 63 HR-10000 Zagreb Phone: +385 (0)1/ 36 67 140 Fax: +385 (0)1/ 36 67 140 e mail: — AutoCont. CZECHIA Control Systems s.r.o. Nemocnicni 12 CZ-702 00 Ostrava 2 Phone: +420 59 / 6152 111 Fax: +420 59 / 6152 562 e mail: consys@autocont.cz louis poulsen DENMARK industri & automation Geminivej 32 DK-2670 Greve Phone: +45 (0) 43 / 95 95 95 Fax: +45 (0) 43 / 95 95 91 e mail: lpia@lpmail.com UTU POWEL OY FINLAND Box 33 FIN-04251 Kerava Phone: +358 (9) 274 6420 Fax: +358 (9) 274 64141 e mail: — Antonios Drepanias S.A. GREECE 52, Arkadias Str. GR-12132 Peristeri, Athens Phone: +30 (10) 578 1599 Fax: +30 (10) 578 1082 e mail: drepanco@hellasnet.gr Meltrade Automatika Kft. HUNGARY 55, Harmat St. HU-1105 Budapest Phone: +36 (0)1 / 2605 602 Fax: +36 (0)1 / 2605 602 e mail: office@meltrade.hu MITSUBISHI ELECTRIC IRELAND EUROPE B.V. – Irish Branch Westgate Business Park IRL-Dublin 24 Phone: +353 (0) 1 / 419 88 00 Fax: +353 (0) 1 / 419 88 90 e mail: sales.info@meir.mee.com RIFAS UAB LITHUANIA Tinklu 29A LT-5300 Panevezys Phone: +370 (5) 582-728 Fax: +370 (5) 582-729 e mail: info@rifas.lt | Imtech NETHERLANDS Marine & Industry Sluisjesdijk 155 NL-3008 AB-Rotterdam Phone: +31 (0) 10 / 487 19 11 Fax: +31 (0) 10 / 487 16 92 e mail: info@renhs.nl SCANELEC AS NORWAY Leirvikasen 43B N-5020 Bergen Phone: +47 55 50 60 00 Fax: +47 55 50 60 01 e mail: scanelec@scanelec.no MPL Technology SP. z.o.o. POLAND ul. Sliczna 36 PL-31-444 Kraków Phone: +48 (0) 12 / 632 28 85 Fax: +48 (0) 12 / 632 47 82 e mail: krakow@mpl.pl Sirius Trading & Services srl ROMANIA Bd. Lacul Tei nr. 1 B RO-72301 Bucuresti 2 Phone: +40 (0) 21 / 201 7147 Fax: +40 (0) 21 / 201 7148 e mail: sirius_t_s@fx.ro INEA d.o.o. SLOVENIA Stegne 11 SI-1000 Ljubljana Phone: +386 (0) 1- 513 8100 Fax: +386 (0) 1- 513 8170 e mail: inea@inea.si Euro Energy SWEDEN Components AB Järnvägsgatan 36 S-434 24 Kungsbacka Phone: +46 (0) 300 / 69 00 40 Fax: +46 (0) 300 / 1 64 75 e mail: info@euroenergy.se TRIELEC AG SWITZERLAND Mühlentalstr. 136 CH-8200 Schaffhausen Phone: +41 (0) 52 / 625 84 25 Fax: +41 (0) 52 / 625 88 25 e mail: info@trielec.ch GTS TURKEY Darülaceze Cad. No. 43 KAT. 2 TR-80270 Okmeydani-Istanbul Phone: +90 (0) 212 / 320 1640 Fax: +90 (0) 212 / 320 1649 e mail: gts@turk.net | GINO INDUSTRIES LTD. ISRAEL 26, Ophir street IL-32235 Haifa Phone: +972 (0) 4 / 867 06 56 Fax: +972 (0) 4 / 867 42 27 e mail: gino-ind@actcom.co.il AVTOMATIKA SEVER RUSSIA Krapivnij Per. 5, Of. 402 RUS-194044 St Petersburg Phone: +7 812 / 1183 238 Fax: +7 812 / 3039 648 e mail: pav@avtsev.spb.ru CONSUS RUSSIA Promyshlennaya St. 42 RUS-198099 St Petersburg Phone: +7 812 / 325 36 53 Fax: +7 812 / 325 36 53 e mail: consys@consus.spb.ru ICOS RUSSIA Ryazanskij Prospekt, 8a, Office 100 RUS-109428 Moscow Phone: +7 095 / 232 - 0207 Fax: +7 095 / 232 - 0327 e mail: mail@icos.ru CBI Ltd SOUTH AFRICA Private Bag 2016 ZA-1600 Isando Phone: +27 (0) 11 / 928 2000 Fax: +27 (0) 11 / 392 2354 e mail: cbi@cbi.co.za |
| MITSUBISHI ELECTRIC EUROPE B.V. FRANCE 25, Boulevard des Bouvets F-92741 Nanterre Cedex Phone: +33 1 55 68 55 68 Fax: +33 1 55 68 56 85 e mail: factory.automation@fra.mee.com | MITSUBISHI ELECTRIC EUROPE B.V. ITALY Italian Branch C.D. Colleoni - P. Perseo Ing. 2 Via Paracelso 12 I-20041 Agrate Brianza (MI) Phone: +39 (0) 39 / 60 53 1 Fax: +39 (0) 39 / 60 53 312 e mail: factory.automation@it.mee.com | MITSUBISHI ELECTRIC EUROPE B.V. SPAIN Carretera de Rubí 76-80 E-08190 Sant Cugat del Vallés (Barcelona) Phone: +34 9 3 / 565 3131 Fax: +34 9 3 / 589 2948 | MITSUBISHI ELECTRIC EUROPE B.V. UK UK Branch Travellers Lane GB-Hatfield Herts. AL10 8 XB Phone: +44 (0) 1707 / 27 61 00 Fax: +44 (0) 1707 / 27 86 95 |
| MITSUBISHI ELECTRIC CORPORATION JAPAN 8-12,1 chome, HARUMI CHUO-KU, Office Tower „Z“ 14 F Tokyo 104-6212 Phone: +81 3 6221 6060 Fax: +81 3 6221 6075 | MITSUBISHI ELECTRIC AUTOMATION USA 500 Corporate Woods Parkway Vernon Hills, Illinois 60061 Phone: +1 (0) 847 / 478 21 00 Fax: +1 (0) 847 / 478 22 83 | | |