

# Solid State Contactor DCS 1500 (10 A)

## Data sheet



### Description

The DCS 1500 is a solid state contactor, for optimized switching of loads in the DC grid.

Impressive features make the DCS 1500 interesting for any application:

- Wear-free
- Maintenance free
- No ozone formation
- Overload protected
- Short circuit protected

Typical applications:

- General load contactor
- Heating contactor (railway heaters)
- Air-conditioning contactor
- Pre-charging contactor
- and others...

### Insulation characteristics

Rated voltage	V <sub>DC</sub>	1500
Max. Operating voltage	V <sub>DC</sub>	2000
Rated impulse voltage*	kV	6
Test voltage (EN 50124-1)	kV <sub>DC</sub>	5
Clearance distance (EN 50124-1)	mm	> 40
Creepage distance (EN 50124-1)	mm	> 56
Comparative Tracking Index (CTI)	–	> 600

\* Transients above 3kV are passed to the connected load  
Higher rated impulse voltages are possible in combination with a surge arrester, please contact Widap

### Electrical characteristics

Contact type	–	1 / NO
Rated current* (100% ED, @55 °C)	A <sub>DC</sub>	10
Max. Operating current* (50% ED, @55 °C, max. cycle time 5 min on - 5 min off)	A <sub>DC</sub>	13
Min. Operating current (for reliable load detection)	A <sub>DC</sub>	1
Voltage drop (@ rated current)	V <sub>DC</sub>	< 2.5
Power loss (@ rated current)	W	< 25
Permissible load inductance	mH	10

\* See derating

Changes due to technical progress are reserved. Our General Conditions of Sale and Delivery apply (available under [www.widap.com/en/gtc/](http://www.widap.com/en/gtc/)).

# Solid State Contactor DCS 1500 (10 A)

## Data sheet



### Time characteristics

Turn on delay ( $t_{d-on}$ )	ms	< 70
Turn off delay ( $t_{d-off}$ ) ((basic delay))	ms	< 60
Min. pulse width ( $t_{p-min}$ )	ms	> 500
Voltage drop-out ( $t_{drop-out}$ ) (EN 50155, Class S2)	ms	$\leq 10$

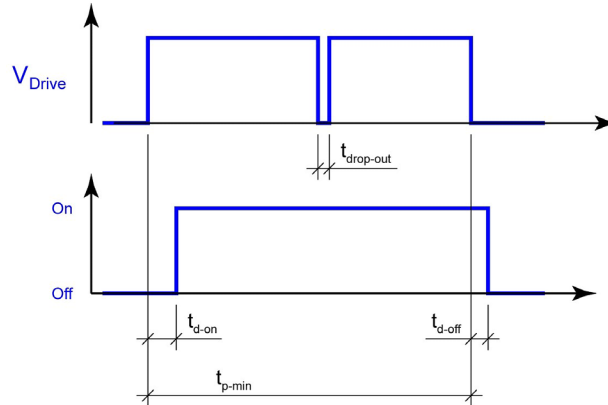

### Mechanical characteristics

Protection degree main connections (EN 60529)	–	IP00
Protection degree housing (EN 60529)	–	IP40
Fire protection (EN 45545-2)	–	R22/HL2, R23/HL2
Mechanical endurance (@ rated load) (IEC 60077-2, Cat. A1)	Cycles	> 1 Mio.
Mechanical endurance (@ load free) (IEC 60077-2, Cat. C3)	Cycles	> 10 Mio.
Shock/Vibration (IEC 61373)	–	Cat. 1/Class B
Weight	kg	1.2

### Dimension drawing

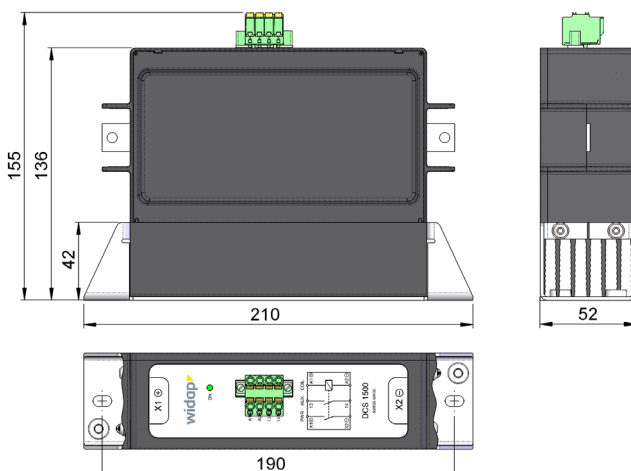

### Circuit diagram

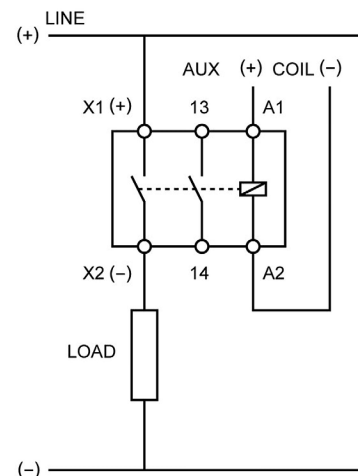

Changes due to technical progress are reserved. Our General Conditions of Sale and Delivery apply (available under [www.widap.com/en/gtc/](http://www.widap.com/en/gtc/)).

# Solid State Contactor DCS 1500 (10A)

## Data sheet



### Derating

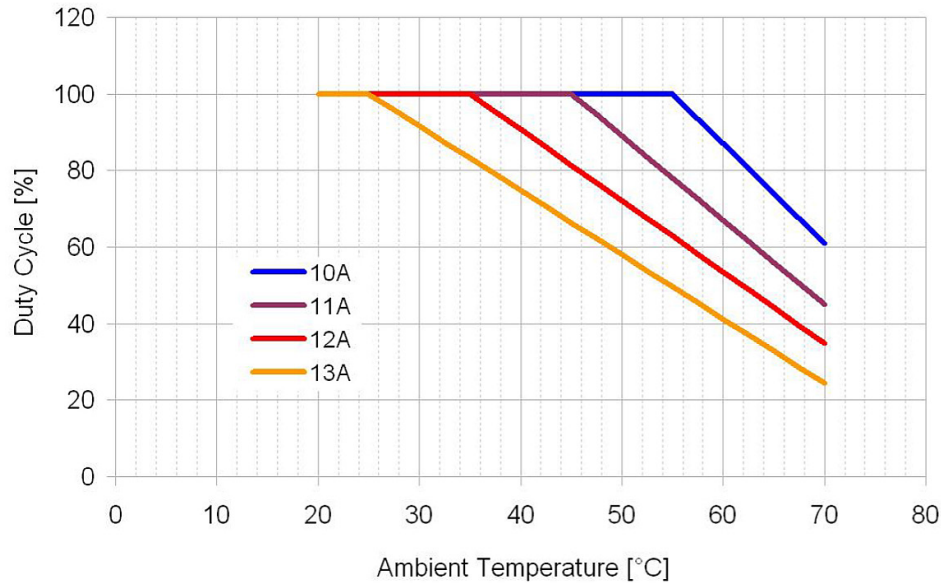

### Control circuit

Control voltage (EN 50155, -30 % / +25 %)	V <sub>DC</sub>	24 ÷ 110
Control current (@ 24 V <sub>DC</sub> )	mA <sub>DC</sub>	< 100
Control current (@ 110 V <sub>DC</sub> )	mA <sub>DC</sub>	< 25

### Auxiliary contact

Contact type	–	1 / NO
Max. Operating voltage (AC/DC)*	V	60
Max. Operating current (AC/DC)*	A	1

\* Both AC and DC operation possible. For AC operation, the specifications correspond to the peak values.

### Environmental conditions

Stock temperature range	°C	-40 ÷ +80
Operational temperature range (EN 50155, Class TX)	°C	-40 ÷ +70
Overvoltage category (EN 50124-1)	–	OV3
Pollution Degree (EN 50124-1)	–	PD3
Air humidity	%	< 95
Operating altitude (without derating)	m	2000
Ventilation	–	Natural convection

Changes due to technical progress are reserved. Our General Conditions of Sale and Delivery apply (available under [www.widap.com/en/gtc/](http://www.widap.com/en/gtc/)).

# Solid State Contactor DCS 1500 (10 A)

## Data sheet

### Connection

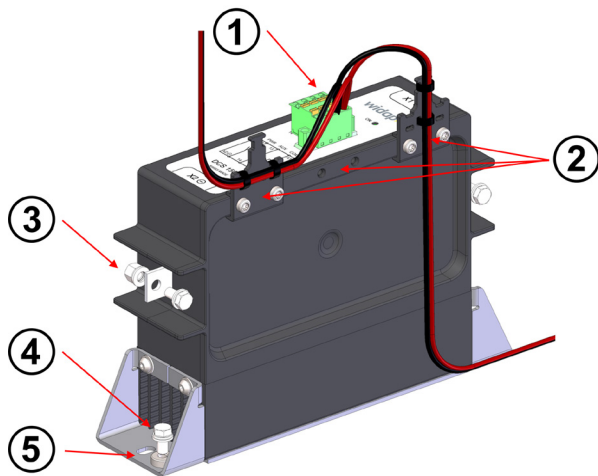

- 1 Connector for control voltage / auxiliary contact (max. 2x2.5 mm<sup>2</sup>)
- 2 Cable strain relief (included in delivery)  
Tightening torque: 3 Nm
- 3 Load connection (2xM5)  
Tightening torque: 6.5 Nm
- 4 Ground connection (2xM5)  
Tightening torque: 6.5 Nm
- 5 Oblong hole for fixation (2xM5)

### Mounting position & distances

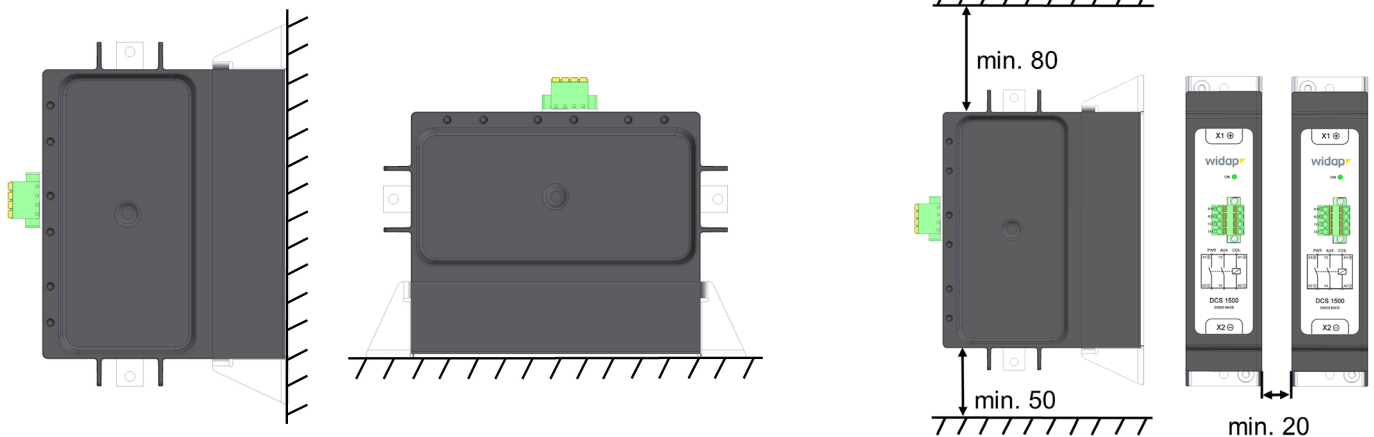

### Reference Standards

EN 45545-2	EN 45545-2 Issue: 2021	Railway applications – Fire protection on railway vehicles – Part 2: requirements for fire behavior of materials and components
EN 50121-3-2	EN 50121-3-2 Issue: 2016	Railway applications – Electromagnetic compatibility – Part 3-2: rolling stock – Apparatus
EN 50124-1	EN 50124-1 Issue: 2017	Railway applications – Insulation coordination – Part 1: basic requirements – Clearances and creepage distances for all electrical and electronic equipment
EN 50155	EN 50155 Issue: 2017	Railway applications – Rolling stock – Electronic equipment
EN 50163	EN 50163 Issue: 2004	Railway applications – Supply voltages of traction systems
IEC 60077-1	IEC 60077-1 Issue: 2017	Railway applications – Electric equipment for rolling stock – Part 1: General service conditions and general rules
IEC 60077-2	IEC 60077-2 Issue: 2017	Railway applications – Electric equipment for rolling stock – Part 2: Electrotechnical components – General rules
IEC 61373	IEC 61373 Issue: 2010	Railway applications – Rolling stock equipment – Shock and vibration tests

Changes due to technical progress are reserved. Our General Conditions of Sale and Delivery apply (available under [www.widap.com/en/gtc/](http://www.widap.com/en/gtc/)).